

SIEMENS

Ingenuity for life



SIMATIC PCS 7 Standard Architectures

SIMATIC PCS 7 V9.0

<https://support.industry.siemens.com/cs/ww/de/view/109751791>

Siemens
Industry
Online
Support





Legal Information

Warning notice system

This manual contains information that must be observed to ensure your personal safety and to prevent property damage. Notices referring to your personal safety are highlighted in the manual by a safety alert symbol; notices referring to property damage only have no safety alert symbol. The notices shown below are graded according to the degree of danger.

 DANGER	indicates that death or severe personal injury will result if proper precautions are not taken.
--	--

 WARNING	indicates that death or severe personal injury may result if proper precautions are not taken.
---	---

 CAUTION	indicates that minor personal injury may result if proper precautions are not taken.
---	---

CAUTION	indicates that damage to property may result if proper precautions are not taken.
----------------	--

If multiple levels of hazards can occur, the warning is always displayed with the highest possible level. A notice warning of injury to persons with a safety alert symbol may also include a warning relating to property damage.

Qualified personnel

The product/system described in this documentation may be operated only by personnel qualified for the specific task in accordance with the relevant documentation, in particular its warning notices and safety instructions. Qualified personnel are those who, based on their training and experience, are capable of identifying risks and avoiding potential hazards when working with these products/systems.

Proper use of Siemens products

Note the following:

 CAUTION	Siemens products may only be used for the applications described in the catalog and in the relevant technical documentation. If products and components from other manufacturers are used, they must be recommended or approved by Siemens. Proper transport, storage, installation, assembly, commissioning, operation, and maintenance are required to ensure that the products operate safely and without any problems. The permissible ambient conditions must be adhered to. The information in the relevant documentation must be observed.
---	--

Registered trademarks

All names identified by ® are registered trademarks of the Siemens AG. Third parties using for their own purposes any other names in this document which refer to trademarks might infringe upon the rights of the trademark owners.

Disclaimer of liability

We have reviewed the contents of this publication for agreement with the hardware and software described. Nevertheless, we cannot assume responsibility for any deviations that may arise. However, the information in this publication is reviewed regularly and any necessary corrections are included in subsequent editions.

Security information

Siemens provides products and solutions with industrial security functions that support the secure operation of plants, systems, machines and networks.

In order to protect plants, systems, machines and networks against cyber threats, it is necessary to implement – and continuously maintain – a holistic, state-of-the-art industrial security concept. Siemens' products and solutions only form one element of such a concept.

Customers are responsible for preventing unauthorized access to their plants, systems, machines and networks. Systems, machines and components should only be connected to the enterprise network or the internet if and to the extent necessary and with appropriate security measures (e. g. use of firewalls and network segmentation) in place.

Additionally, Siemens' guidance on appropriate security measures must be taken into account. For more information about industrial security, please visit <http://www.siemens.com/industrialsecurity>.

Siemens' products and solutions undergo continuous development to make them more secure. Siemens strongly recommends applying product updates as soon as available and always using the latest product versions. Using versions that are obsolete or are no longer supported can increase the risk of cyber threats.

To stay informed about product updates, subscribe to the Siemens Industrial Security RSS Feed under <http://www.siemens.com/industrialsecurity>.

Table of Contents

	Legal Information	2
1	Introduction	7
2	Selection guide.....	9
2.1	Entry level systems (for example PCS 7 BOX RTX)	10
2.2	Single station system	10
2.3	Multi user system.....	11
2.4	Client server system	11
2.5	Client server system with several servers.....	12
3	Entry level systems	13
3.1	Entry level system with dual monitor	14
3.2	Separate ES in the entry level system.....	15
3.3	Entry level SIMATIC PCS 7 BOX RTX as an ES and OS client	16
3.4	SIMATIC PCS 7 AS RTX system	18
4	Single user system.....	19
4.1	Single user station with dual monitor	19
4.2	Single user system with PCS 7 Web server.....	21
5	System with multiple OS single stations.....	23
5.1	Multiple OS single stations with dual monitor.....	25
5.2	Redundant OS single station	27
5.3	Plain system configuration without OS server.....	29
6	OS client / OS server system	32
6.1	OS client / OS server with operator control and monitoring on the ES and OS server.....	33
6.2	OS client / OS server operation on a redundant server architecture.....	35
6.3	OS client / OS server system with a PCS 7 web server	37
6.4	OS client / OS server system with terminal server	39
6.5	OS client / OS server system with DataMonitor server.....	42
6.6	OS client / OS server with Dual Monitor	44
6.7	OS client / OS server system with multi user Engineering	46
7	SIMATIC BATCH.....	48
7.1	SIMATIC BATCH single user system	49
7.2	SIMATIC BATCH single user system in an OS client / OS server architecture.....	51
7.3	SIMATIC BATCH OS client / OS server	53
7.4	Separate SIMATIC BATCH server	55
7.5	Redundant SIMATIC BATCH client / server architecture	58
7.6	SIMATIC BATCH client / server architecture redundant (OS + SB server separated).....	61
8	SIMATIC Route Control	64
8.1	SIMATIC Route Control single user system.....	65
8.2	SIMATIC Route Control client / server architecture.....	67
8.3	Redundant SIMATIC Route control client / server architecture	69
8.4	SIMATIC Route Control client / server architecture redundant (OS + RCS server separated).....	72
9	SIMATIC Route Control and SIMATIC BATCH.....	75
10	Archiving	77

10.1	OS client / OS server	79
10.2	Redundant OS server pair and single Process Historian	81
10.3	Redundant OS server pair and redundant Process Historian	84
11	Fieldbus	87
11.1	DP-PA / DP-FF Fieldbus	90
11.2	Single optical DP-PA / DP-FF Fieldbus	93
11.3	Redundant DP-PA / DP-FF Fieldbus	96
11.4	Redundant optical DP-PA / DP-FF Fieldbus	99
11.5	PROFINET Fieldbus with a standard automation system	102
11.6	PROFINET Fieldbus with a highly available automation system – simple system redundancy S2	104
11.7	Redundant PROFINET Fieldbus with a highly available automation system - R1	106
12	SIMATIC PDM	109
12.1	Local service and parameter assignment station on the fieldbus	111
12.2	Local service and parameter assignment station on the fieldbus	113
12.3	SIMATIC PDM and PCS 7 Starter System	115
12.4	SIMATIC PDM and PCS 7 single user system	117
12.5	SIMATIC PDM and PCS 7 OS client / OS server system	119
12.6	SIMATIC PDM and non-SIMATIC S7 master	122
12.7	SIMATIC PDM Stand-alone server	124
13	Maintenance Station (Asset Management)	126
13.1	PCS 7 Maintenance Station in the starter system	127
13.2	PCS 7 maintenance station in single user system	129
13.3	PCS 7 Maintenance Station in a multi-user system with MS / OS clients and combined MS / OS server	134
13.4	PCS 7 Maintenance Station in a multi user system with MS / OS clients and separate MS server and red. OS server	139
13.5	PCS 7 Maintenance Station in a multi user system with MS / OS clients and separate redundant MS server pair and OS server pair	142
13.6	Asset management in flat hierarchies	148
13.7	SIMATIC PDM Maintenance Station	151
14	SIMATIC Management Console	152
14.1	Basic functions of the Management Console	152
14.2	Functions of the Management Console	152
14.2.1	Functions for software administration	152
14.2.2	Functions for determining inventory data	153
15	Network architecture	156
15.1	Overview	156
15.2	Ring architectures	159
15.2.1	High-speed ring fault tolerance	159
15.2.2	Ring connectivity, standby redundancy	160
15.3	Redundancy concepts - terminal bus	161
15.3.1	Introduction	161
15.3.2	Redundant terminal bus	162
15.4	Redundancy concepts - plant bus	163
15.4.1	Introduction	163
15.4.2	Standard automation system	163
15.4.3	High-availability automation system AS 410	166
15.5	Exemplary configurations	170
15.5.1	Fault-tolerant ring architectures with glass fiber	170
15.5.2	Electrical fault-tolerant ring architectures	172

Table of Contents

15.5.3	Electrical fault-tolerant ring structures with combined plant and terminal bus.....	174
15.5.4	Redundant bus architectures with fault-tolerant rings	175
15.5.5	Redundant bus architectures with fault-tolerant rings and combined plant and terminal bus.....	177
16	Process safety	178
17	24 V DC supply concepts	179
17.1	Basic power supplies	180
17.2	Redundant power supply	181
17.3	Redundant power supply system	182
17.4	Redundant power supply with selective monitoring of the 24 V feeders	183
17.5	Buffered power supply	185
17.6	Redundant power supply with buffering.....	187
17.7	Redundant power supply with redundant buffering	189
17.8	Power supply system with selective monitoring and buffering	192
18	Possibilities for data exchange.....	194
18.1	Small OS client / OS server system and OpenPCS 7	195
18.2	Large OS client / OS server system and OpenPCS 7	198
19	AS-OS PO counting.....	202
19.1	Process objects	202
19.2	Cumulative licenses.....	203
20	Service and Support.....	205
21	Appendix.....	206
21.1	References.....	206
21.2	History.....	206

1 Introduction

This document describes the architectures and components of SIMATIC PCS 7 in a basic structure. In addition to the mentioned architectures, various options and configured versions are also displayed. SIMATIC PCS 7 is a highly scalable process control system with numerous topologies that are based on redundancy as well as optional hardware and software features.

This document should help you by simplifying your choice:

- Architectures based on the number of users, inputs and outputs
- SIMATIC PCS 7-Optionen, for example. SIMATIC BATCH, SIMATIC Route Control, Asset management and Fieldbus
- Degree of system availability and network topologies
- Power supply concepts for DC 24 V

The various configurations in this document are compared on the basis of schematic diagrams and a sample component list.

Note The architectures shown in this document contain only the necessary basic licenses. In order to achieve the desired quantity structure, in addition to the basic licenses, you must also take into account the corresponding set of volume licenses.

Note The components on the bill of materials refer to the 2017 PCS 7 catalog: <https://www.siemens.com/STPCS7>
You may need to check whether more up-to-date components are available.

Note The bill of materials for the individual configurations do not contain any network components, since a large number of variants are available for this. To do this, use Chapter [15](#) Network architecture.

You can also find the "PCS 7 - PC configuration (V9.0)" manual by clicking on this link: <https://support.industry.siemens.com/cs/ww/en/view/109749317>

This document contains additional information about the PC components that are used with PCS 7.

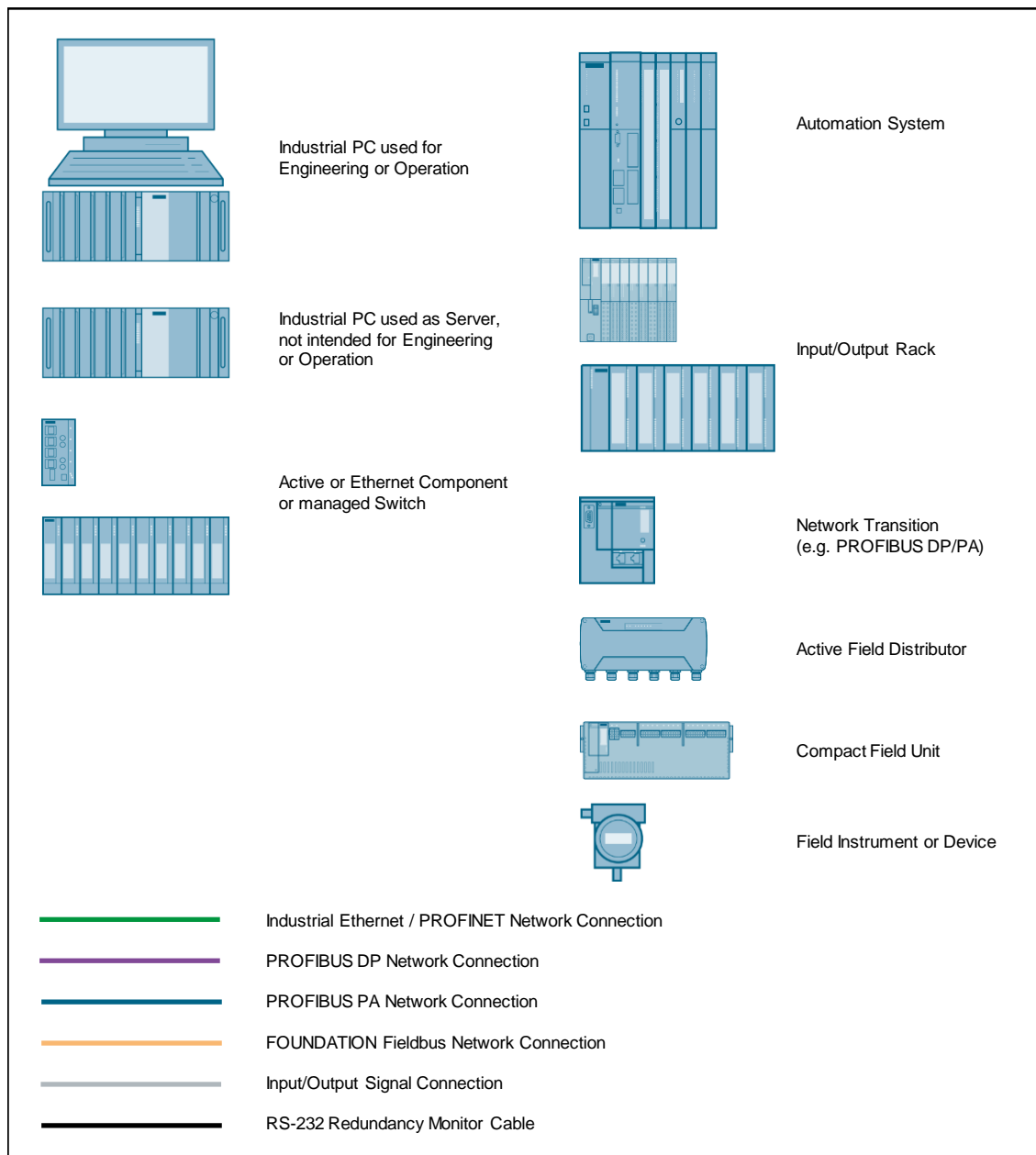

© Siemens AG 2019. All rights reserved

Note

This legend shows schematic representations of the components and does not show the real picture of the individual components, as their shape, the terminal type and the modular structure of the selected components may be different.

2 Selection guide

At the planning stage, the task is to create a Distributed Control System (DCS) with a scalable and flexible architecture.

The sample configurations that are listed below will help you to choose the right configuration to meet your requirements and demands of the properties you need like the size, availability and number of operator stations.

Every configuration in this document contains a bill of materials that provides an overview of the PCS 7 components that are used.

When choosing your architecture, you should first determine the following system criteria:

1. Number of inputs and outputs for the process
2. Number of operators that work with the system

Number of inputs and outputs connected to the system

To determine the number of signals entering or leaving the system, you must consider several media:

1. The number of digital and analog I/Os to be installed.
2. The number of variables (boolean, integer or floating point) exchanged between the PCS 7 system and external systems such as PLCs, serial interfaces, etc., and running on protocols such as Modbus, PROFIBUS, PROFINET or Ethernet.
3. Inputs and outputs that are read or written via bus systems, such as AS-Interface.

Number of persons operating the system

The chosen architecture must be designed for the total number of users, operators and engineers who will work on the system in the future. This number determines the required number of individual workplaces.

Note

SIMATIC PCS 7 enables a seamless extension of your system with full use of existing equipment. Both software and hardware components satisfy this requirement equally.

2.1 Entry level systems (for example PCS 7 BOX RTX)

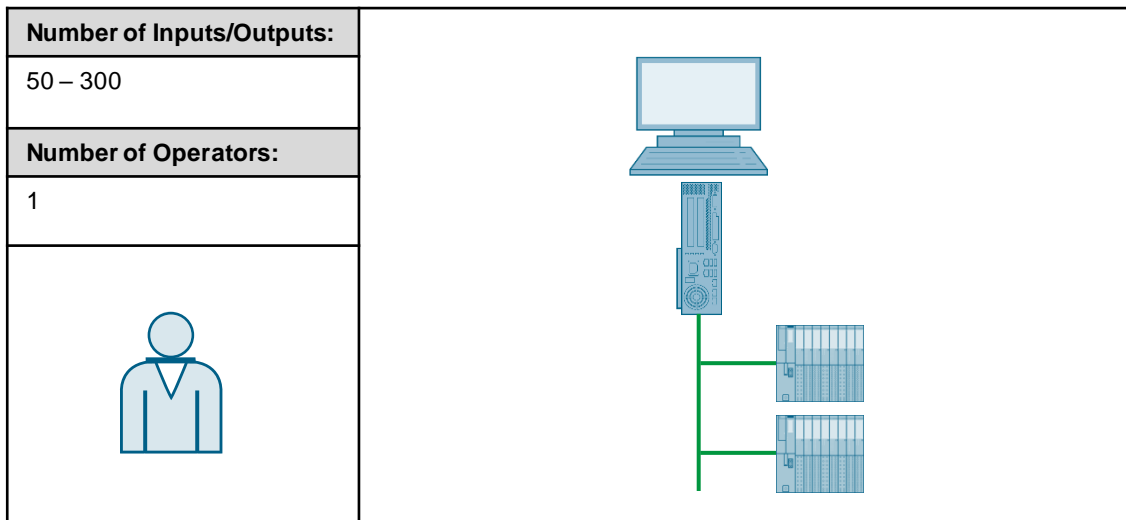

2.2 Single station system

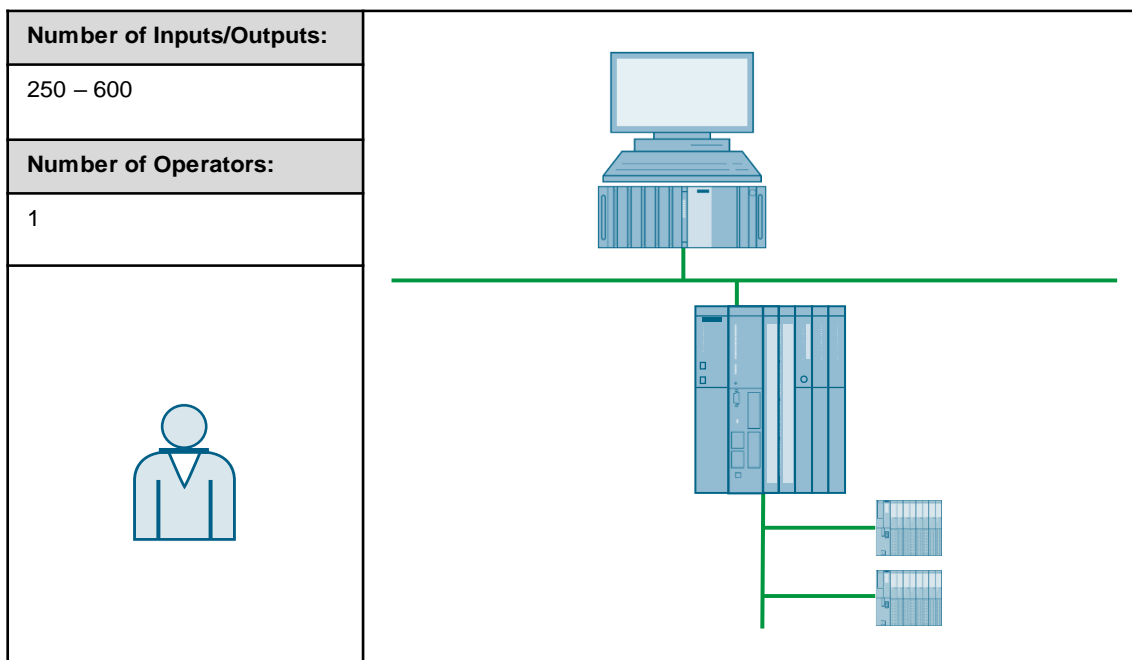

2.3 Multi user system

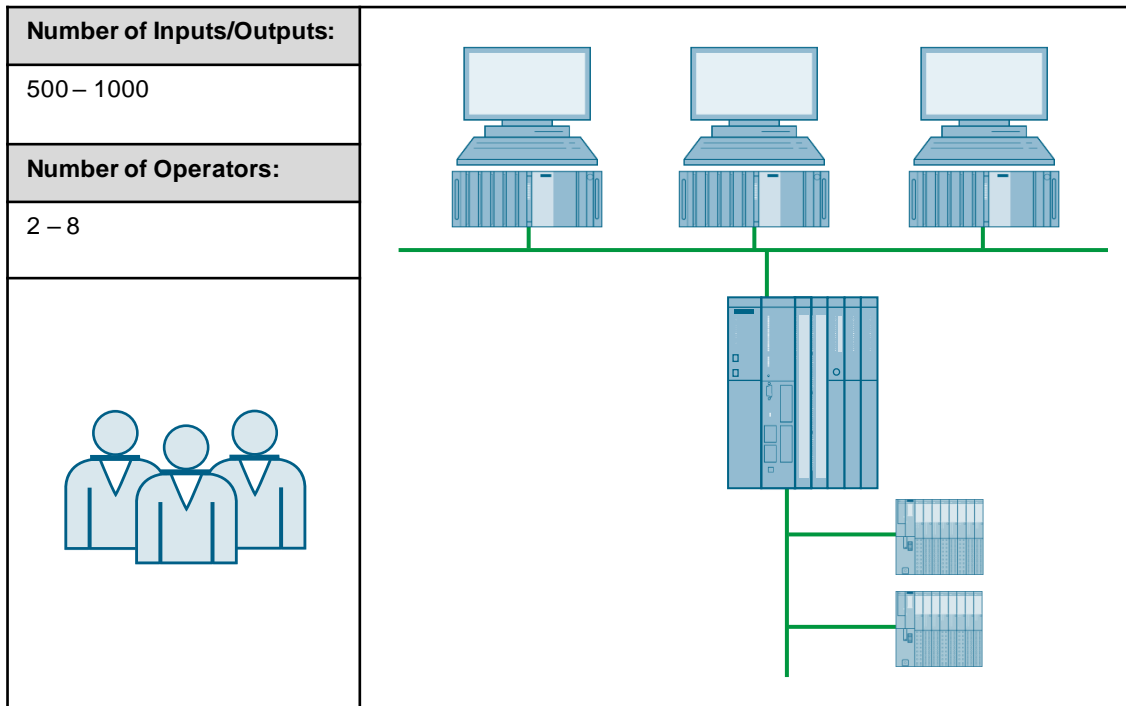

2.4 Client server system

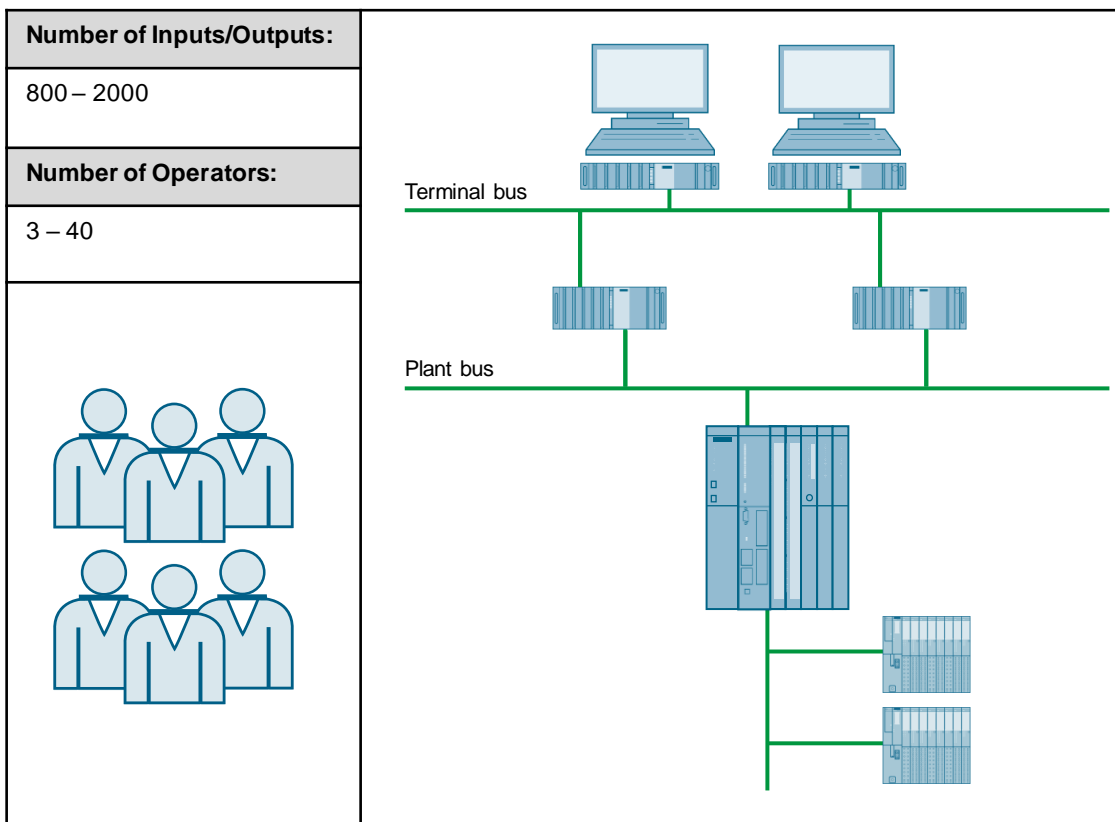

2.5 Client server system with several servers

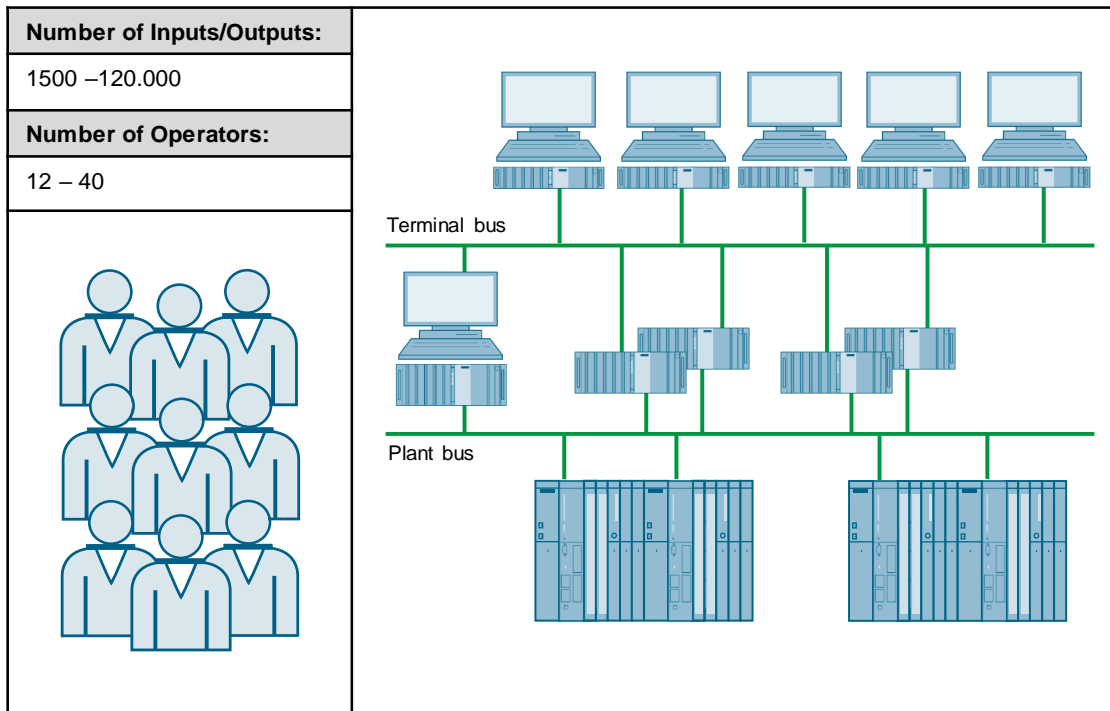

3 Entry level systems

Entry level systems

If one or two operators and less than 300 I/Os must be supported, the SIMATIC PCS 7 BOX RTX system is a powerful and cost-effective solution.

The PCS 7 BOX RTX has a software AS based on the proven Windows Automation Center (WinAC) technology. This software CPU runs with the Ardence RTX® real-time operating system under Windows. It provides high-performance control logic for the design and memory.

The PCS 7 BOX RTX is available in two versions:

1. Automation System (AS), Operator Station (OS) and Engineering Station (ES)
2. Automation System (AS) and Operator Station (OS)

The PCS 7 BOX RTX can be equipped with a 2-screen Multi VGA graphics card which enables the connection of two additional monitors to the system, i.e. a total of four monitors.

Separate Engineering Station

Engineering can be carried out by a separate Engineering System. In this case, the SIMATIC PCS 7 BOX RTX consists of just the AS and OS. This means that the Engineering station can be used as an Operator station when doing this.

SIMATIC PCS 7 BOX RTX as an OS client

When combined with a larger SIMATIC PCS 7 system, the SIMATIC PCS 7 BOX can be used as an OS client for the OS server. At the same time, the AS is connected to the OS server as part of the SIMATIC PCS 7 BOX RTX.

SIMATIC PCS 7 AS RTX system

SIMATIC PCS 7 provides a Microbox automation system with a software controller for less demanding applications. The Microbox system is based on the SIMATIC Microbox IPC427D platform, on which the Windows 7 operating system runs. When combined with the Windows real-time extension Ardence RTX® and the WinAC RTX 2010 software controller, this system offers a compact controller for applications at the system level.

SIMATIC PCS 7 OS Client IPC427E (Microbox)

The SIMATIC Microbox PC is also available as an OS client as version SIMATIC IPC427E PCS 7 OS Client and can be used in SIMATIC PCS 7 systems as a client for the Operator station and SIMATIC BATCH.

Note

Fieldbus components, racks, modules and field devices are not listed in the following bill of materials.

3.1 Entry level system with dual monitor

In this configuration, the PCS 7 BOX RTX system is used as an ES, OS, and AS with two monitors.

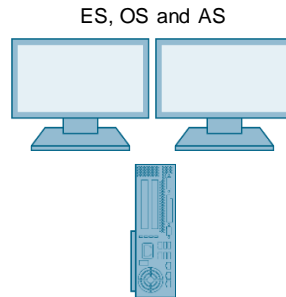

Bill of materials

Required	Optional	Article number	Product description	Note
Engineering Station, Operator Station, and Automation System				
1		6ES7650-4BB10-3RA0	PCS 7 V9.0 BOX RTX ES/OS SYSTEM (WINAC RTX 2010), WINDOWS 7 ULTIMATE 32BIT, PROFINET ONBOARD, PCS 7 V9.0 PREINSTALLED	1) 2)
	1	6ES7652-0XD58-2YB5	SOFTWARE SIMATIC PCS 7 SFC VISUALIZATION V9.0	
	1	6ES7658-1CX58-2YA5	SOFTWARE SIMATIC PCS 7 VERSION CROSS MANAGER V9.0	
	1	6ES7658-1FX58-2YA5	SOFTWARE SIMATIC PCS 7 VERSION TRAIL V9.0	
	1	6ES7658-1DX58-2YB5	SOFTWARE SIMATIC PCS 7 IMPORT EXPORT ASSISTANT V9.0	
		24 V DC power supply	Buffered power supply	Chapter 17.5

Note

¹⁾ Please use the PCS 7 BOX configurator, since different versions of the PCS 7 BOX are available; e. g., 24V DC or 110/230V AC.

²⁾ The number of POs can be increased later by means of extra volume licenses.

3.2 Separate ES in the entry level system

In this configuration, the PCS 7 BOX RTX system is used as an OS and AS. The ES is designed as a separate system.

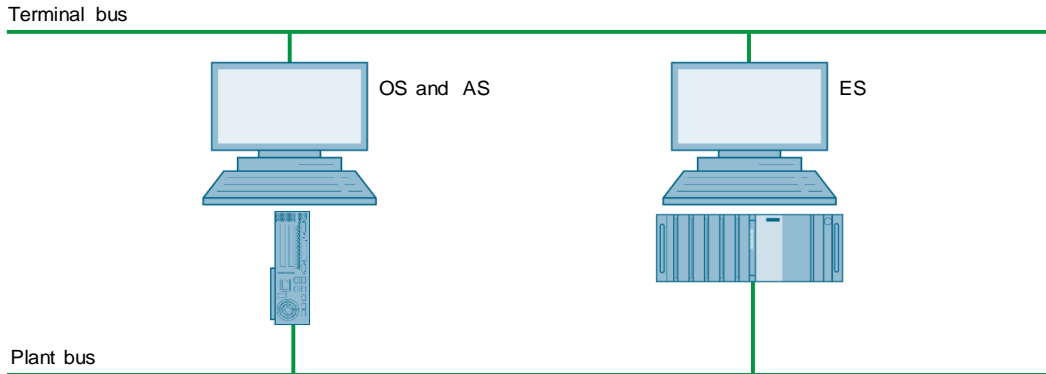

Bill of materials

Required	Optional	Article number	Product description	Note
Operator Station and Automation System				
1		6ES7650-4BB10-3SA0	PCS 7 V9.0 BOX RTX OS RUNTIME (WINAC RTX 2010), WINDOWS 7 ULTIMATE 32BIT, PROFINET ONBOARD, PCS 7 V9.0 PREINSTALLED	1) 2)
	1	6ES7652-0XD58-2YB5	SOFTWARE SIMATIC PCS 7 SFC VISUALIZATION V9.0	
Engineering Station				
1		6ES7660-6DA10-3BA0	SIMATIC PCS 7 INDUSTRIAL WORKSTATION IPC847D, CORE I5, ES/OS SINGLESTATION, 500 GB HD SATA, 8GB DDR3, BCE, PCS 7 V9.0, WINDOWS 10 ENTERPRISE 2015 LTSB 64BIT	3)
1		6ES7658-5AX58-0YA5	SOFTWARE SIMATIC PCS 7 AS/OS ENGINEERING V9.0	
	1	6ES7658-1CX58-2YA5	SOFTWARE SIMATIC PCS 7 VERSION CROSS MANAGER V9.0	
	1	6ES7658-1FX58-2YA5	SOFTWARE SIMATIC PCS 7 VERSION TRAIL V9.0	
	1	6ES7658-1DX58-2YB5	SOFTWARE SIMATIC PCS 7 IMPORT EXPORT ASSISTANT V9.0	

Note

- 1) Please use the PCS 7 BOX configurator, since different versions of the PCS 7 BOX are available; e. g., 24V DC or 110/230V AC.
- 2) The number of POs can be increased later by means of extra volume licenses.
- 3) The Engineering station is not intended for use as a second Operator station.

3.3 Entry level SIMATIC PCS 7 BOX RTX as an ES and OS client

In this configuration, the PCS 7 BOX RTX system is used as an ES, OS and AS. The OS server is designed as a separate system.

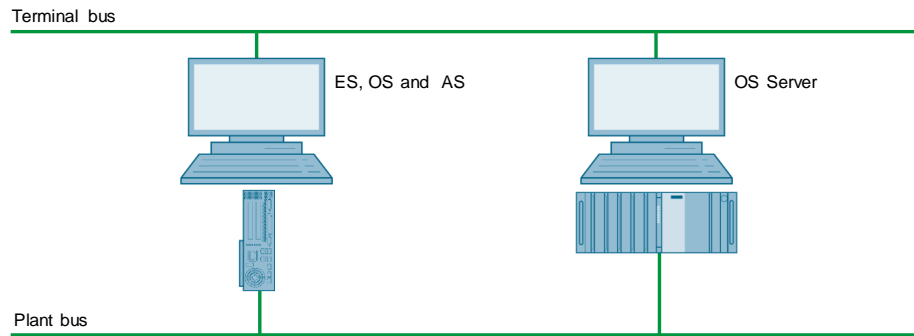

Bill of materials

Required	Optional	Article number	Product description	Note
Engineering Station, Operator Station and Automation System				
1		6ES7650-4BB10-3RA0	PCS 7 V9.0 BOX RTX ES/OS SYSTEM (WINAC RTX 2010), WINDOWS 7 ULTIMATE 32BIT, PROFINET ONBOARD, PCS 7 V9.0 PREINSTALLED	1) 2)
	1	6ES7652-0XD58-2YB5	SOFTWARE SIMATIC PCS 7 SFC VISUALIZATION V9.0	
	1	6ES7658-1CX58-2YA5	SOFTWARE SIMATIC PCS 7 VERSION CROSS MANAGER V9.0	
	1	6ES7658-1FX58-2YA5	SOFTWARE SIMATIC PCS 7 VERSION TRAIL V9.0	
	1	6ES7658-1DX58-2YB5	SOFTWARE SIMATIC PCS 7 IMPORT EXPORT ASSISTANT V9.0	
OS server				
1		6ES7660-6EC10-3EA0	SIMATIC PCS 7 INDUSTRIAL WORKSTATION IPC847D, CORE I5, OS-SERVER, RAID1 (2 X 1 TB HDD SATA, DATA MIRRORING), 8GB DDR3, BCE, PCS 7 V9.0, WIN SERVER 2012 R2 STANDARD EDITION INCL. 5 CLIENT 64BIT	
1		6ES7658-2BA58-0YA0	SOFTWARE SIMATIC PCS 7 OS-SERVER V9.0 (PO 100)	2)
	1	6ES7652-0XD58-2YB5	SOFTWARE SIMATIC PCS 7 SFC VISUALIZATION V9.0	
		24 V DC power supply	Buffered power supply	Chapter 17.5

Note

¹⁾ Please use the PCS 7 BOX configurator, since different versions of the PCS 7 BOX are available; e. g., 24V DC or 110/230V AC.

²⁾ The number of POs can be increased later by means of extra volume licenses.

3.4 SIMATIC PCS 7 AS RTX system

In this configuration, the PCS 7 BOX RTX system is used as an AS. The ES and OS are configured on a separate system.

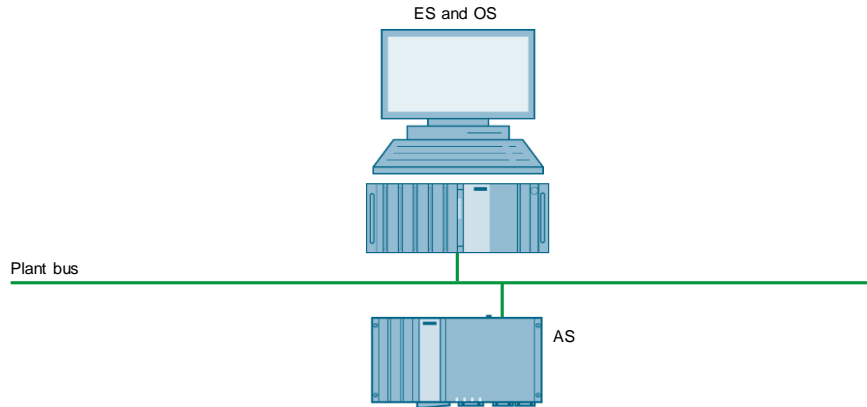

Bill of materials

Required	Optional	Article number	Product description	Note
Automation system				
1		6ES7654-0UE23-0XX2	SIMATIC PCS 7 AS RTX PROFINET AUTOMATION SYSTEM BASED ON IPC427D, AS RT PO 100	1) 2)
		24 V DC power supply	Buffered power supply	Chapter 17.5
Engineering Station and Operator Station				
1		6ES7660-6DA10-3BA0	SIMATIC PCS 7 INDUSTRIAL WORKSTATION IPC847D, CORE I5, ES/OS SINGLESTATION, 500 GB HD SATA, 8GB DDR3, BCE, PCS 7 V9.0, WINDOWS 10 ENTERPRISE 2015 LTSB 64BIT	
1		6ES7651-5AA58-0YA0	SIMATIC PCS 7, SOFTWARE, ES SINGLE STATION V9.0 (AS/OS: 250 POs)	1)
	1	6ES7652-0XD58-2YB5	SOFTWARE SIMATIC PCS 7 SFC VISUALIZATION V9.0	
	1	6ES7658-1CX58-2YA5	SOFTWARE SIMATIC PCS 7 VERSION CROSS MANAGER V9.0	
	1	6ES7658-1FX58-2YA5	SOFTWARE SIMATIC PCS 7 VERSION TRAIL V9.0	
	1	6ES7658-1DX58-2YB5	SOFTWARE SIMATIC PCS 7 IMPORT EXPORT ASSISTANT V9.0	

Note

- 1) The number of POs can be increased later by means of extra volume licenses.
- 2) PCS 7 AS RTX controller needs a 24 V DC power supply.

4 Single user system

Single user system

For small systems where engineering or operation tasks are carried out by only one user the single user architecture of PCS 7 offers a cost-effective solution. In this architecture, the functionality of the Engineering Station (ES) and the Operator Station (OS) is integrated into one PC.

Dual monitor

A single station or an Engineering Station can be expanded with a standard graphics card that makes it possible to connect up to two monitors.

The system can be expanded with an additional multi graphics card (2 additional monitor connections) so that up to four monitors can be connected to one system.

4.1 Single user station with dual monitor

This configuration is a system in which the ES and OS are used on one PC as a single user system with two monitors.

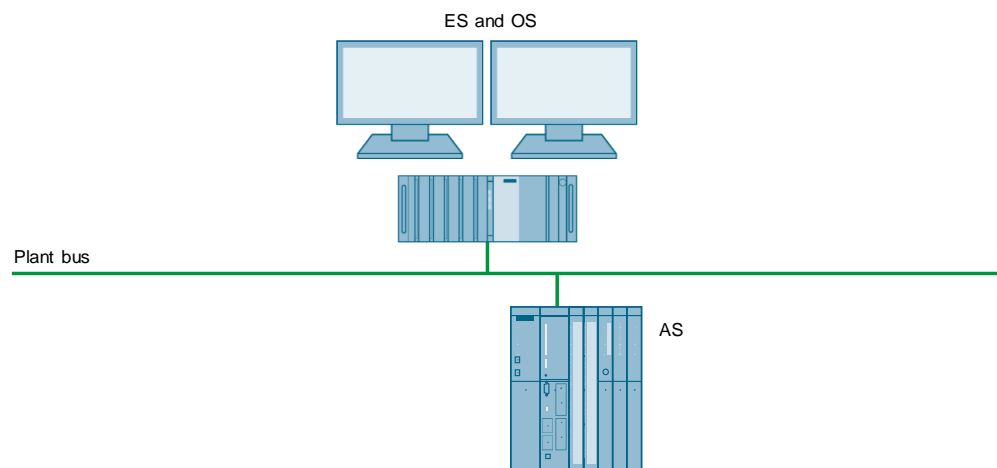

Bill of materials

Required	Optional	Article number	Product description	Note
Engineering Station and Operator Station				
1		6ES7660-6DC10-3BB0	SIMATIC PCS 7 INDUSTRIAL WORKSTATION IPC847D, CORE I5, ES/OS SINGLESTATION, RAID1 (2 x 1 TB HDD SATA, DATA MIRRORING), 8GB DDR3, BCE, MULTI MONITOR 2 SCREENS VIA ONBOARD INTERFACES (ADAPTER CABLE), PCS 7 V9.0, WINDOWS 10 ENTERPRISE 2015 LTSB 64BIT	
1		6ES7651-5AA58-0YA0	SIMATIC PCS 7, SOFTWARE, ES SINGLE STATION V9.0 (AS/OS: 250 POs)	1)
	1	6ES7652-0XD58-2YB5	SOFTWARE SIMATIC PCS 7 SFC VISUALIZATION V9.0	
	1	6ES7658-1CX58-2YA5	SOFTWARE SIMATIC PCS 7 VERSION CROSS MANAGER V9.0	
	1	6ES7658-1FX58-2YA5	SOFTWARE SIMATIC PCS 7 VERSION TRAIL V9.0	
	1	6ES7658-1DX58-2YB5	SOFTWARE SIMATIC PCS 7 IMPORT EXPORT ASSISTANT V9.0	
Automation system				
1		6ES7654-6CL03-3BF0	SIMATIC PCS 7 SINGLE AS, CPU 410-5H, SYSTEM EXPANSIONS CARD 500 PO, AS RT PO 100, CP443-1IE, UR2 ALU RACK, UC 120/230V 10A POWER SUPPLY	1) 2)
		24 V DC power supply	Redundant power supply	Chapter 17.2

Note

1) The number of POs can be increased later by means of extra volume licenses.

2) Please use the PCS 7 AS configurator, since different versions of the PCS 7 AS 410-5H are available; e. g., 24V DC or 110/230V AC.

4.2 Single user system with PCS 7 Web server

This configuration is a system in which the ES, OS, and PCS 7 Web server are used on one PC as a single user system. The PCS 7 Web clients are connected via the terminal bus.

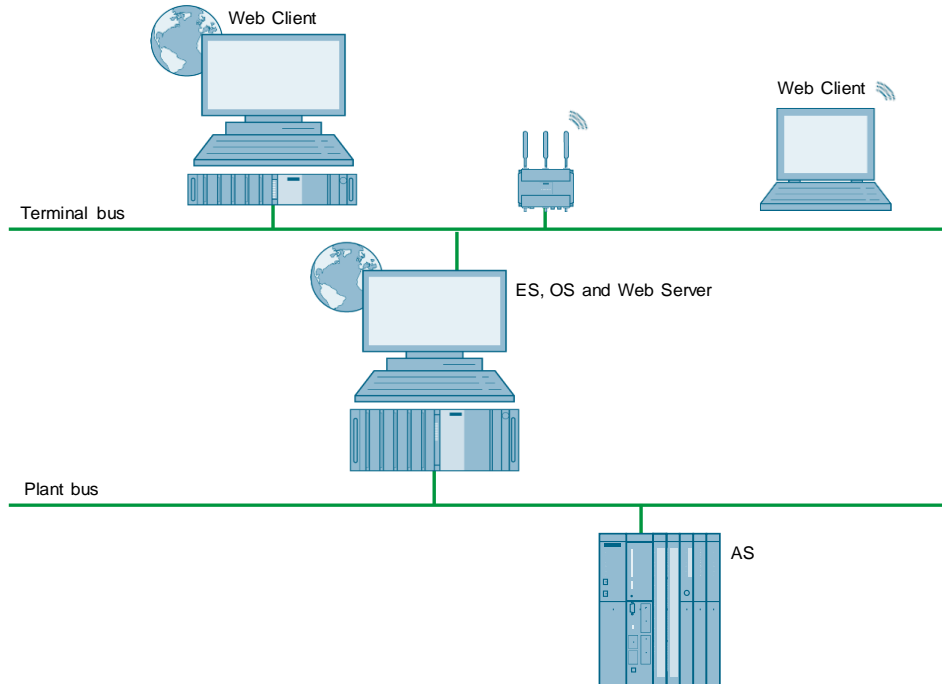

Bill of materials

Required	Optional	Article number	Product description	Note
Engineering Station and Operator Station				
1		6ES7660-6DC10-3BB0	SIMATIC PCS 7 INDUSTRIAL WORKSTATION IPC847D, CORE I5, ES/OS, RAID1 (2 x 1 TB HDD SATA, DATA MIRRORING), 8GB DDR3, MULTI MONITOR 2 SCREENS VIA ONBOARD INTERFACES (ADAPTER CABLE), BCE, PCS 7 V9.0, WINDOWS 10 ENTERPRISE 2015 LTSC 64BIT	
1		6ES7651-5AA58-0YA0	SIMATIC PCS 7, SOFTWARE, ES SINGLE STATION V9.0 (AS/OS: 250 POs)	1)
1		6ES7658-2HX58-2YB0	SOFTWARE SIMATIC PCS 7 WEB DIAGNOSTICS SERVER V9.0	4)

Required	Optional	Article number	Product description	Note
	1	6ES7652-0XD58-2YB5	SOFTWARE SIMATIC PCS 7 SFC VISUALIZATION V9.0	
	1	6ES7658-1CX58-2YA5	SOFTWARE SIMATIC PCS 7 VERSION CROSS MANAGER V9.0	
	1	6ES7658-1FX58-2YA5	SOFTWARE SIMATIC PCS 7 VERSION TRAIL V9.0	
	1	6ES7658-1DX58-2YB5	SOFTWARE SIMATIC PCS 7 IMPORT EXPORT ASSISTANT V9.0	
Wireless LAN				
1		6GK1907-0DC10-6AA3	POWER M12 CABLE CONNECTOR PRO	5)
1		6XV1870-3QH60	SIMATIC NET INDUSTRIAL ETHERNET IE TP CORD RJ45/RJ45, 6M	
Automation system				
1		6ES7654-6CL03-3BF0	SIMATIC PCS 7 SINGLE AS, CPU 410-5H, SYSTEM EXPANSIONS CARD 500 PO, AS RT PO 100, CP443-1IE, UR2 ALU RACK, UC 120/230V 10A POWER SUPPLY	1) 2)
		24 V DC power supply	Redundant power supply	Chapter 17.2
Web client system				
2		6ES7658-2HX58-2YB0	SOFTWARE SIMATIC PCS 7 WEB DIAGNOSTICS SERVER V9.0	4)

Note

The laptop (web clients) hardware is not listed.

- 1) The number of POs can be increased later by means of extra volume licenses.
- 2) Please use the PCS 7 AS configurator, since different versions of the PCS 7 AS 410-5H are available; e. g., 24V DC or 110/230V AC.
- 3) Wireless LAN access point with approval for the USA and Canada; approval for other countries requires a different version of W786-RJ45.
- 4) As an alternative to the Diagnostic licenses for servers and clients, server-based licensing can be selected for up to three web clients.
- 5) The selected cable is based on the architecture in which Access Point W786-1 RJ45 is powered by a separate 24V DC power source.

5 System with multiple OS single stations

System with multiple OS single stations

Two to five users and typically up to 1000 inputs and outputs can be supported and controlled with one SIMATIC PCS 7 system composed of several single stations.

In an architecture like this, the system can consist of up to eight single stations. The single stations are configured and loaded on a central basis from an Engineering Station (ES) in a single OS project. Since the entire database is copied to all the single stations, the entire plant can be controlled from one single location. It can be archived simultaneously on all the single stations. However, there is no synchronization between the single locations, and archives for alarms and tags run independently from each other.

Redundancy

With linking of a Process Historian (PH), two OS single stations must be set up on a redundant basis; otherwise, the link does not work. A corresponding system configuration can be found in chapter 5.3. Two OS single stations can be equipped with redundancy software and hardware components to create a highly available Operator Station. In this case, the archive synchronization is carried out between the redundant single stations.

The terminal bus, system bus, automation system(s) (AS) and Fieldbus can also be set up on a redundant basis. This redundancy option for the OS is limited to two OS single stations.

Configuration limits

OS single station configurations are intended for small- and medium-sized plants in the lower range. If more than two OS single stations are to be deployed, a client / server architecture is generally more economical.

By contrast with OS servers, OS single stations have the following restrictions:

- Released number: eight OS Single Stations
- Max. number of process objects per OS single station: 8,500 POs
- Number of measuring points per OS single station approx. 4,500

Dual monitor

Each OS or ES can be expanded with the onboard standard graphics card and an appropriate adapter cable such that it is possible to connect two monitors.

The systems can be expanded with an additional Multi graphics card (2 additional monitor connections) that makes it possible to connect up to four monitors to one system.

Note

For more than one redundant pair of OSs, neither archive synchronization nor redundancy for alarms and process variables between one another are available.

When connected with SIMATIC BATCH, there is a restriction that allows BATCH to be used on only one of the OS single stations. A separate project must be created for this OS single station.

5.1 Multiple OS single stations with dual monitor

In this configuration, the system has several OS Single Stations and one separate ES. The ES and the OS are each fitted with two monitors.

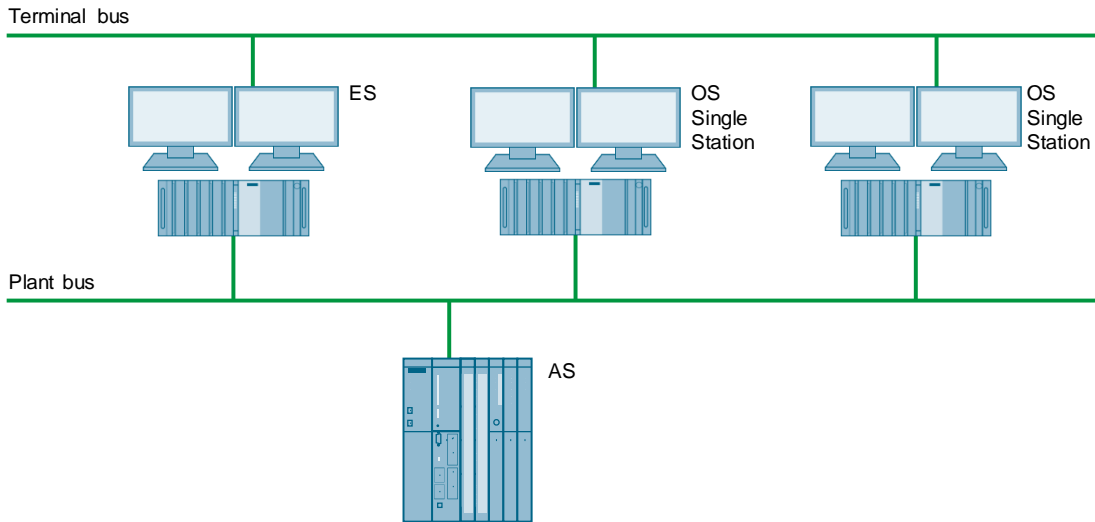

Bill of materials

Required	Optional	Article number	Product description	Note
Engineering Station				
1		6ES7660-6DC10-3BB0	SIMATIC PCS 7 INDUSTRIAL WORKSTATION IPC847D, CORE I5, ES/OS, RAID1 (2 x 1 TB HDD SATA, DATA MIRRORING), 8GB DDR3, MULTI MONITOR 2 SCREENS VIA ONBOARD INTERFACES (ADAPTER CABLE), BCE, PCS 7 V9.0, WINDOWS 10 ENTERPRISE 2015 LTSB 64BIT	
1		6ES7658-5AX58-0YA5	SOFTWARE SIMATIC PCS 7 AS/OS ENGINEERING V9.0	
	1	6ES7658-1CX58-2YA5	SOFTWARE SIMATIC PCS 7 VERSION CROSS MANAGER V9.0	
	1	6ES7658-1FX58-2YA5	SOFTWARE SIMATIC PCS 7 VERSION TRAIL V9.0	
	1	6ES7658-1DX58-2YB5	SOFTWARE SIMATIC PCS 7 IMPORT EXPORT ASSISTANT V9.0	

Required	Optional	Article number	Product description	Note
Operator Station				
2		6ES7660-6DC10-3BB0	SIMATIC PCS 7 INDUSTRIAL WORKSTATION IPC847D, CORE I5, ES/OS, RAID1 (2 x 1 TB HDD SATA, DATA MIRRORING), 8GB DDR3, MULTI MONITOR 2 SCREENS VIA ONBOARD INTERFACES (ADAPTER CABLE), BCE, PCS 7 V9.0, WINDOWS 10 ENTERPRISE 2015 LTSB 64BIT	
2		6ES7658-2AA58-0YA0	SIMATIC PCS 7, OS SOFTWARE, SINGLE STATION V9.0 incl. 100 OS RUNTIME PO	1)
	2	6ES7652-0XD58-2YB5	SOFTWARE SIMATIC PCS 7 SFC VISUALIZATION V9.0	
Automation system				
1		6ES7654-6CN03-3BF0	SIMATIC PCS 7 SINGLE AS, CPU 410-5H, 1X DP-MODULE, 2x PROFINET-IO, SYSTEM EXPANSION CARD 1000 PO, AS RT PO 100, CP443-1IE, UR2 ALU RACK, 1 X UC 120/230V 10A POWER SUPPLY	2)
		24 V DC power supply	Redundant power supply	Chapter 17.2

Note

- 1) The number of POs can be increased later by means of extra volume licenses.
- 2) Please use the PCS 7 AS configurator, since different versions of the PCS 7 AS 410-5H are available; e. g., 24V DC or 110/230V AC.

5.2 Redundant OS single station

In this configuration, the system has one redundant OS single station. The ES is configured on a separate PC.

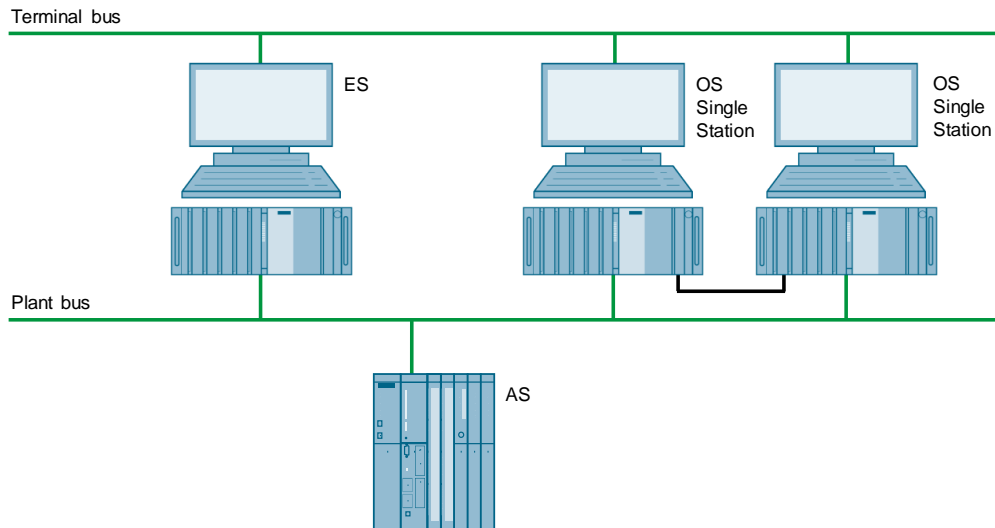

Bill of materials

Required	Optional	Article number	Product description	Note
Engineering Station				
1		6ES7660-6DC11-3BB0	SIMATIC PCS 7 INDUSTRIAL WORKSTATION IPC847D, CORE I5, ES/OS SINGLESTATION, RAID1 (2 X 1 TB HDD SATA, DATA MIRRORING), 8GB DDR3, INDUSTRIAL ETHERNET (CP1623), PCS 7 V9.0, WINDOWS 10 ENTERPRISE 2015 LTSB 64BIT	
1		6GK1162-3AA00	SIMATIC NET COMMUNICATION PROCESSOR CP 1623 PCI EXPRESS	1)
1		6ES7658-5AX58-0YA5	SOFTWARE SIMATIC PCS 7 AS/OS ENGINEERING V9.0	
1		6ES7658-1CX58-2YA5	SOFTWARE SIMATIC PCS 7 VERSION CROSS MANAGER V9.0	
1		6ES7658-1FX58-2YA5	SOFTWARE SIMATIC PCS 7 VERSION TRAIL V9.0	
1		6ES7658-1DX58-2YB5	SOFTWARE SIMATIC PCS 7 IMPORT EXPORT ASSISTANT V9.0	
Operator Station				
2		6ES7660-6DC11-3BB0	SIMATIC PCS 7 INDUSTRIAL WORKSTATION IPC847D, CORE I5, ES/OS SINGLESTATION, RAID1 (2 X 1 TB HDD SATA, DATA MIRRORING), 8GB DDR3, INDUSTRIAL ETHERNET (CP1623), PCS 7 V9.0, WINDOWS 10 ENTERPRISE 2015 LTSB 64BIT	
2		6GK1162-3AA00	SIMATIC NET COMMUNICATION PROCESSOR	1)

Required	Optional	Article number	Product description	Note
			CP 1623 PCI EXPRESS	
1		6ES7652-3AA58-2YA0	SOFTWARE SIMATIC PCS 7 OS SINGLE STATION REDUNDANCY V9.0 (PO 100)	2) 5)
2		6GK1716-0HB14-0AC0	SIMATIC NET, S7-REDCONNECT POWERPACK V14	3)
2		6GK1711-1EW14-0AA0	SIMATIC NET SOFTNET-IE RNA V14 REDUNDANT NETWORK ACCESS	1) 6) 7)
	2	6ES7652-0XD58-2YB5	SOFTWARE SIMATIC PCS 7 SFC VISUALIZATION V9.0	
Automation system				
1		6ES7654-6CL03-3BF0	SIMATIC PCS 7 SINGLE AS, CPU 410-5H, SYSTEM EXPANSIONS CARD 500 PO, AS RT PO 100, CP443-1IE, UR2 ALU RACK, UC 120/230V 10A POWER SUPPLY	4)
		24 V DC power supply	Redundant power supply	Chapter 17.2

Note

- 1) Necessary if a redundant system bus is selected.
- 2) The number of POs can be increased later by means of extra volume licenses.
- 3) Necessary if a redundant system bus or a redundant automation system is selected.
- 4) Please use the PCS 7 AS configurator, since different versions of the PCS 7 AS 410-5H are available; e. g., 24V DC or 110/230V AC.
- 5) The redundant OS single station is supplied with an RS-232 serial connection cable. If there is a long distance between the redundant systems, you can use an Ethernet connection instead. This requires additional Ethernet network interface cards in the PCs.
- 6) The onboard interfaces can be used.
- 7) Single license for one installation.

5.3 Plain system configuration without OS server

For small- and medium-sized plants, implementation is possible in a very plain system configuration without an OS server. In this case, OS single user stations are used, and the number can be expanded up to a maximum of 8 single user stations.

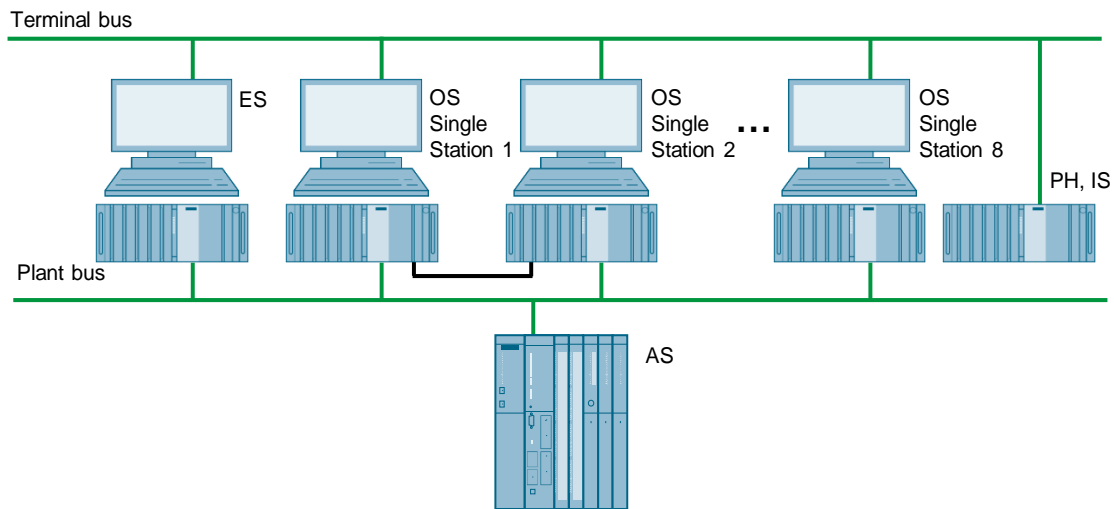

Bill of materials

Required	Optional	Article number	Product description	Note
Engineering Station				
1		6ES7660-6DA11-3BA0	SIMATIC PCS 7 INDUSTRIAL WORKSTATION IPC847D, CORE I5, ES/OS SINGLESTATION, 500 GB HDD SATA, 8GB DDR3, INDUSTRIAL ETHERNET (CP1623), PCS 7 V9.0, WINDOWS 10 ENTERPRISE 2015 LTSB 64BIT	
	1	6GK1162-3AA00	SIMATIC NET COMMUNICATION PROCESSOR CP 1623 PCI EXPRESS	1)
	1	6GK1711-1EW14-0AA0	SIMATIC NET SOFTNET-IE RNA V14 REDUNDANT NETWORK ACCESS	1)
1		6ES7658-5AX58-0YA5	SOFTWARE SIMATIC PCS 7 AS/OS ENGINEERING V9.0	
	1	6ES7658-1CX58-2YA5	SOFTWARE SIMATIC PCS 7 VERSION CROSS MANAGER V9.0	
	1	6ES7658-1FX58-2YA5	SOFTWARE SIMATIC PCS 7 VERSION TRAIL V9.0	
	1	6ES7658-1DX58-2YB5	SOFTWARE SIMATIC PCS 7 IMPORT EXPORT ASSISTANT V9.0	

5 System with multiple OS single stations

Required	Optional	Article number	Product description	Note
Operator Station				
3		6ES7660-6DF11-3BA0	SIMATIC PCS 7 INDUSTRIAL WORKSTATION IPC847D, CORE I5, ES/OS SINGLESTATION, RAID1 (2 X 1 TB HDD SATA, DATA MIRRORING), 8GB DDR3, INDUSTRIAL ETHERNET (CP1623), PCS 7 V9.0, WINDOWS 10 ENTERPRISE 2015 LTSB 64BIT	
	3	6GK1162-3AA00	SIMATIC NET COMMUNICATION PROCESSOR CP 1623 PCI EXPRESS	1)
	3	6GK1711-1EW14-0AA0	SIMATIC NET SOFTNET-IE RNA V14 REDUNDANT NETWORK ACCESS	1)
1		6ES7652-3AA58-2YA0	SOFTWARE SIMATIC PCS 7 OS SINGLE STATION REDUNDANCY V9.0 (PO 100)	2) 5)
1	5	6ES7652-3AA58-0YA0	SOFTWARE SIMATIC PCS 7 OS SINGLE STATION V9.0 (PO 100)	2)
	3	6GK1716-0HB14-0AC0	SIMATIC NET, S7-REDCONNECT POWERPACK V14	3)
	3	6ES7652-0XD58-2YB5	SOFTWARE SIMATIC PCS 7 SFC VISUALIZATION V9.0	
Process Historian / Information Server				
	1	6ES7660-6HN38-3EA0	SIMATIC PCS 7 INDUSTRIAL WORKSTATION IPC847D, XEON E3, OS-SERVER, RAID1 (2 x 1 TB HDD SATA, DATA MIRRORING) + 240GB SSD SATA, 32GB DDR3, PCS 7 V9.0 OPERATING SYSTEM WINDOWS SERVER 2012 R2 STANDARD EDITION, 64 BIT incl. 5 CAL	
1	1	6ES7652-7AX58-2YB0	SOFTWARE SIMATIC PCS 7 PROCESS HISTORIAN AND INFORMATION SERVER BASIC PACKAGE V9.0	
	1	6ES7652-7YA00-2YB0	SOFTWARE SIMATIC PCS 7 INFORMATION SERVER CLIENT ACCESS (1 CLIENT)	6)
Automation system				
1		6ES7654-6CL03-3BF0	SIMATIC PCS 7 SINGLE AS, CPU 410-5H, SYSTEM EXPANSIONS CARD 500 PO, AS RT PO 100, CP443-1IE, UR2 ALU RACK, UC 120/230V 10A POWER SUPPLY	4)
		24 V DC power supply	Redundant power supply	Chapter 17.2

Note

A common (combined) plant and terminal bus can be set up.

- ¹⁾ Necessary if a redundant bus is selected.
- ²⁾ The number of POs can be increased later by means of extra volume licenses.
- ³⁾ Necessary if a redundant bus or a redundant automation system is selected.
- ⁴⁾ Please use the PCS 7 AS configurator, since different versions of the PCS 7 AS 410-5H are available; e. g., 24V DC or 110/230V AC.
- ⁵⁾ The redundant OS single station is supplied with an RS-232 serial connection cable. If there is a long distance between the redundant systems, you can use an Ethernet connection instead. This requires additional Ethernet network interface cards in the PCs.
- ⁶⁾ The number of clients can be expanded with cumulative Information Server Client Access licenses.

6 OS client / OS server system

Client / server system

Medium to large systems can benefit greatly from the SIMATIC PCS 7 client/server architecture. The central administration of real-time and historical values, easy entry of application changes and cost reduction are all features of SIMATIC PCS 7 systems. The basic system of a client / server architecture is composed of an OS server and two or more OS clients. The ES has a connection to both the terminal bus and the plant bus, so that changes can be loaded both on the OSs and the ASs. If needed and there are no engineering tasks pending, the ES can be used as an OS client.

Operation via server

If you operate no more than four OS clients on one OS server, you can use an OS server as an operator control and monitoring station.

Redundancy

By using a redundant OS server pair (optional redundant Process Historian), SIMATIC PCS 7 can support redundancy at all levels. This means that OS clients accessing real-time / historical values and storage of historical data offer higher availability.

In order to guarantee increased availability on the hardware level, the system supports redundant ring structures.

Dual monitor

OS clients can be expanded with a standard graphics card and an appropriate adapter cable such that it is possible to connect two monitors.

The systems can be expanded with an additional Multi graphics card (2 additional monitor connections) that makes it possible to connect up to four monitors to one system.

Web server

A dedicated OS client can be equipped with the SIMATIC PCS 7 web server software which makes possible operator control and monitoring of up to 100 web clients via the internet / intranet. Server licensing allows more than 100 users to access one web server at the same time.

Note

One OS server supports up to 40 OS clients. The number of OS clients in the system can be greater than 40.

The maximum number of OS servers / OS server pairs in a system is 18; one OS client can be connected to a maximum of 18 OS servers.

6.1 OS client / OS server with operator control and monitoring on the ES and OS server

This configuration is a system in which the ES and OS client are used on one PC. The OS server is configured on a separate PC.

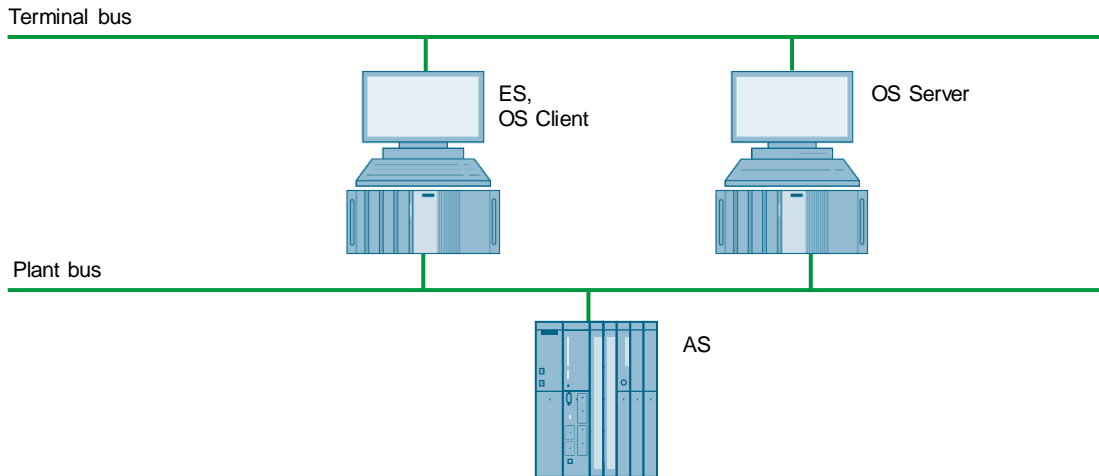

Bill of materials

Required	Optional	Article number	Product description	Note
Engineering Station				
1		6ES7660-6DA10-3BA0	SIMATIC PCS 7 INDUSTRIAL WORKSTATION IPC847D, CORE I5, ES/OS SINGLESTATION, 500 GB HD SATA, 8GB DDR3, BCE, PCS 7 V9.0, WINDOWS 10 ENTERPRISE 2015 LTSB 64BIT	
1		6ES7658-5AX58-0YA5	SOFTWARE SIMATIC PCS 7 AS/OS ENGINEERING V9.0	
	1	6ES7652-0XD58-2YB5	SOFTWARE SIMATIC PCS 7 SFC VISUALIZATION V9.0	
	1	6ES7658-1CX58-2YA5	SOFTWARE SIMATIC PCS 7 VERSION CROSS MANAGER V9.0	
	1	6ES7658-1FX58-2YA5	SOFTWARE SIMATIC PCS 7 VERSION TRAIL V9.0	
	1	6ES7658-1DX58-2YB5	SOFTWARE SIMATIC PCS 7 IMPORT EXPORT ASSISTANT V9.0	
1		6ES7658-2CX58-0YB5	SOFTWARE SIMATIC PCS 7 OS-CLIENT V9.0	2)

Required	Optional	Article number	Product description	Note
OS server				
1		6ES7660-6EC10-3EA0	SIMATIC PCS 7 INDUSTRIAL WORKSTATION IPC847D, CORE I5, OS-SERVER, RAID1 (2 X 1 TB HDD SATA, DATA MIRRORING), 8GB DDR3, BCE, PCS 7 V9.0, WIN SERVER 2012 R2 STANDARD EDITION INCL. 5 CLIENT 64BIT	
1		6ES7658-2BA58-0YA0	SOFTWARE SIMATIC PCS 7 OS-SERVER V9.0 (PO 100)	¹⁾
	1	6ES7652-0XD58-2YB5	SOFTWARE SIMATIC PCS 7 SFC VISUALIZATION V9.0	
Automation system				
1		6ES7654-6CP03-3BF0	SIMATIC PCS 7 SINGLE AS, CPU 410-5H, 1X DP-MODULE, 2x PROFINET-IO, SYSTEM EXPANSION CARD 1600 PO, AS RT PO 100, CP443-1IE, UR2 ALU RACK, 1 X UC 120/230V 10A POWER SUPPLY	³⁾
		24 V DC power supply	Redundant power supply	Chapter 17.2

Note

- ¹⁾ The number of POs can be increased later by means of extra volume licenses.
- ²⁾ The maximum number of OS clients when operating on the OS server is three.
- ³⁾ Please use the PCS 7 AS configurator, since different versions of the PCS 7 AS 410-5H are available; e. g., 24V DC or 110/230V AC.

6.2 OS client / OS server operation on a redundant server architecture

In this configuration, the system has one redundant OS server pair, two OS clients and one separate ES. Both OS servers are designed as operator control and monitoring stations.

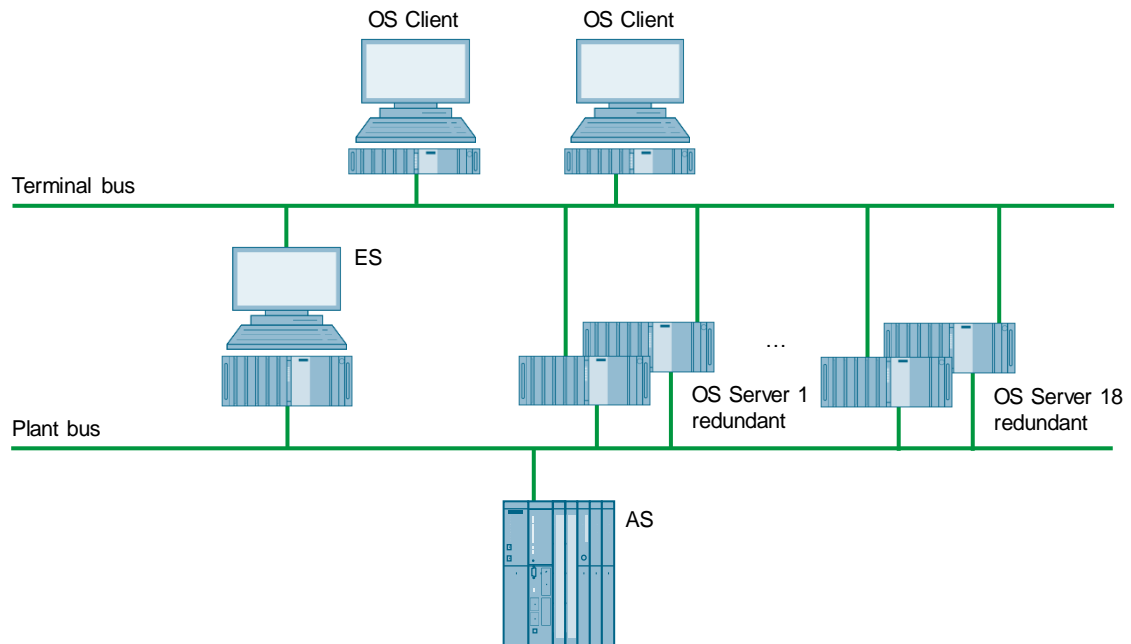

© Siemens AG 2019. All rights reserved

Bill of materials

Required	Optional	Article number	Product description	Note
Engineering Station				
1		6ES7660-6DA10-3BA0	SIMATIC PCS 7 INDUSTRIAL WORKSTATION IPC847D, CORE I5, ES/OS SINGLESTATION, 500 GB HD SATA, 8GB DDR3, BCE, PCS 7 V9.0, WINDOWS 10 ENTERPRISE 2015 LTSC 64BIT	
1		6ES7658-5AX58-0YA5	SOFTWARE SIMATIC PCS 7 AS/OS ENGINEERING V9.0	
	1	6ES7658-1CX58-2YA5	SOFTWARE SIMATIC PCS 7 VERSION CROSS MANAGER V9.0	
	1	6ES7658-1FX58-2YA5	SOFTWARE SIMATIC PCS 7 VERSION TRAIL V9.0	
	1	6ES7658-1DX58-2YB5	SOFTWARE SIMATIC PCS 7 IMPORT EXPORT ASSISTANT V9.0	

Required	Optional	Article number	Product description	Note
OS server				
2	34	6ES7660-6EC10-3EA0	SIMATIC PCS 7 INDUSTRIAL WORKSTATION IPC847D, CORE I5, OS-SERVER, RAID1 (2 X 1 TB HDD SATA, DATA MIRRORING), 8GB DDR3, BCE, PCS 7 V9.0, WIN SERVER 2012 R2 STANDARD EDITION INCL. 5 CLIENT 64BIT	
1	17	6ES7652-3BA58-2YA0	SOFTWARE SIMATIC PCS 7 OS-SERVER REDUNDANCY V9.0 (PO 100)	1) 4)
		6ES7652-0XD58-2YB5	SOFTWARE SIMATIC PCS 7 SFC VISUALIZATION V9.0	
OS client				
2		6ES7660-5FA08-3BA0	SIMATIC PCS 7 INDUSTRIAL WORKSTATION IPC647D, CORE I5, OS-CLIENT, 500 GB HD SATA, 4GB DDR3, PCS 7 V9.0, WINDOWS 10 ENTERPRISE 2015 LTSB 64 Bit	2)
2		6ES7658-2CX58-0YB5	SOFTWARE SIMATIC PCS 7 OS-CLIENT V9.0	
	2	6ES7652-0XD58-2YB5	SOFTWARE SIMATIC PCS 7 SFC VISUALIZATION V9.0	
Automation system				
1		6ES7654-6CN03-3BF0	SIMATIC PCS 7 SINGLE AS, CPU 410-5H, 1X DP-MODULE, 2x PROFINET-IO, SYSTEM EXPANSION CARD 1000 PO, AS RT PO 100, CP443-1IE, UR2 ALU RACK, 1 X UC 120/230V 10A POWER SUPPLY	3)
		24 V DC power supply	Redundant power supply	Chapter 17.2

Note

- 1) The number of POs can be increased later by means of extra volume licenses.
- 2) The maximum number of OS clients when operating on the OS server is three.
- 3) Please use the PCS 7 AS configurator, since different versions of the PCS 7 AS 410-5H are available; e. g., 24V DC or 110/230V AC.
- 4) The redundant OS server pair is supplied with an RS-232 serial connection cable. If there is a long distance between the redundant systems, you can use an Ethernet connection instead. This requires additional Ethernet network interface cards in the systems.

6.3 OS client / OS server system with a PCS 7 web server

In this configuration, the system has one OS server, one OS client and one separate ES. The PCS 7 Web server is configured on a separate PC. The PCS 7 Web clients have separate network access to the PCS 7 Web server.

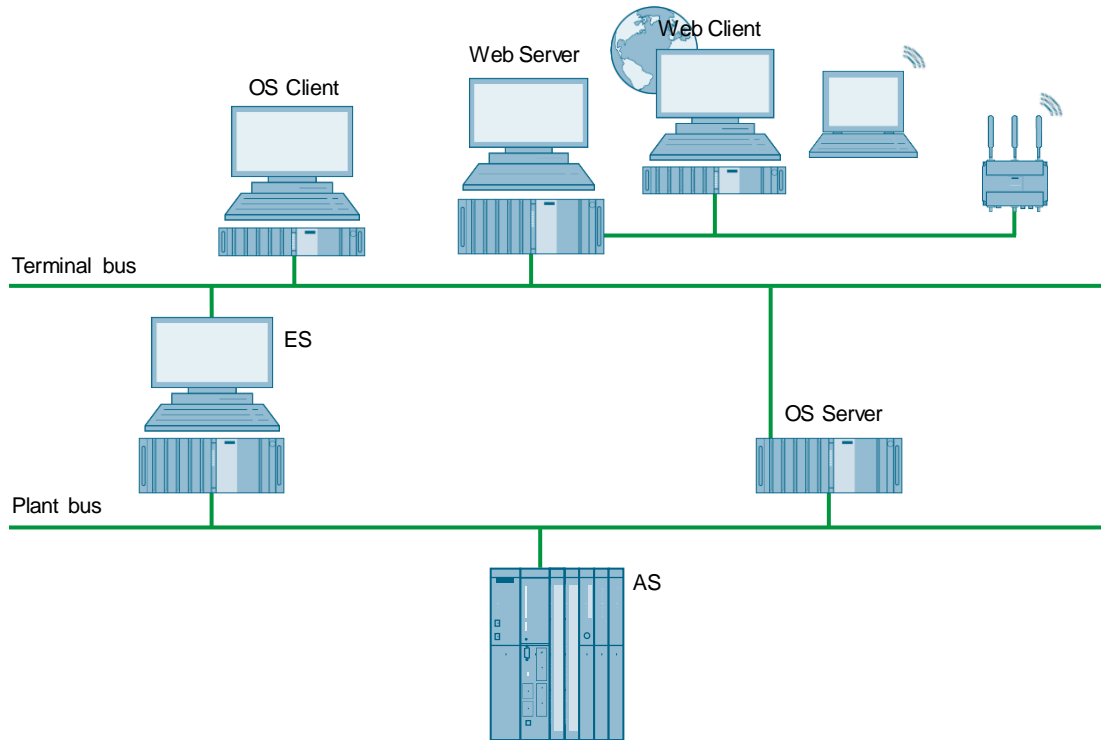

© Siemens AG 2019. All rights reserved

Bill of materials

Required	Optional	Article number	Product description	Note
Engineering Station				
1		6ES7660-6DA10-3BA0	SIMATIC PCS 7 INDUSTRIAL WORKSTATION IPC847D, CORE I5, ES/OS SINGLESTATION, 500 GB HD SATA, 8GB DDR3, BCE, PCS 7 V9.0, WINDOWS 10 ENTERPRISE 2015 LTSB 64BIT	
1		6ES7658-5AX58-0YA5	SOFTWARE SIMATIC PCS 7 AS/OS ENGINEERING V9.0	
	1	6ES7658-1CX58-2YA5	SOFTWARE SIMATIC PCS 7 VERSION CROSS MANAGER V9.0	
	1	6ES7658-1FX58-2YA5	SOFTWARE SIMATIC PCS 7 VERSION TRAIL V9.0	
	1	6ES7658-1DX58-2YB5	SOFTWARE SIMATIC PCS 7 IMPORT EXPORT ASSISTANT V9.0	

Required	Optional	Article number	Product description	Note
OS server				
1		6ES7660-6EC10-3EA0	SIMATIC PCS 7 INDUSTRIAL WORKSTATION IPC847D, CORE I5, OS-SERVER, RAID1 (2 X 1 TB HDD SATA, DATA MIRRORING), 8GB DDR3, BCE, PCS 7 V9.0, WIN SERVER 2012 R2 STANDARD EDITION INCL. 5 CLIENT 64BIT	
1		6ES7658-2BA58-0YA0	SOFTWARE SIMATIC PCS 7 OS-SERVER V9.0 (PO 100)	1)
OS client				
1		6ES7660-5FA08-3BA0	SIMATIC PCS 7 INDUSTRIAL WORKSTATION IPC647D, CORE I5, OS-CLIENT, 500 GB HD SATA, 4GB DDR3, PCS 7 V9.0, WINDOWS 10 ENTERPRISE 2015 LTSB 64 Bit	
1		6ES7658-2CX58-0YB5	SOFTWARE SIMATIC PCS 7 OS-CLIENT V9.0	
	1	6ES7652-0XD58-2YB5	SOFTWARE SIMATIC PCS 7 SFC VISUALIZATION V9.0	
Web server				
1		6ES7660-6EC10-3EA0	SIMATIC PCS 7 INDUSTRIAL WORKSTATION IPC847D, CORE I5, OS-SERVER, RAID1 (2 X 1 TB HDD SATA, DATA MIRRORING), 8GB DDR3, BCE, PCS 7 V9.0, WIN SERVER 2012 R2 STANDARD EDITION INCL. 5 CLIENT 64BIT	
1		6ES7658-2CX58-0YB5	SOFTWARE SIMATIC PCS 7 OS-CLIENT V9.0	
1		6ES7658-2GX58-2YB0	SOFTWARE SIMATIC PCS 7 WEB SERVER BASIC V9.0	
1		6ES7658-2GF00-0XB0	SOFTWARE SIMATIC PCS 7 WEB SERVER (5 CLIENTS)	2)
	1	6ES7652-0XD58-2YB5	SOFTWARE SIMATIC PCS 7 SFC VISUALIZATION V9.0	
Automation system				
1		6ES7654-6CN03-3BF0	SIMATIC PCS 7 SINGLE AS, CPU 410-5H, 1X DP-MODULE, 2x PROFINET-IO, SYSTEM EXPANSION CARD 1000 PO, AS RT PO 100, CP443-1IE, UR2 ALU RACK, 1 X UC 120/230V 10A POWER SUPPLY	3)
		24 V DC power supply	Redundant power supply	Chapter 17.2

Note

Laptops that are used as web clients are not listed. Wireless LAN that is used for laptop connection is not listed.

1) The number of POs can be increased later by means of extra volume licenses.

2) The number of web clients can be increased later on by means of cumulative web server licenses.

3) Please use the PCS 7 AS configurator, since different versions of the PCS 7 AS 410-5H are available; e. g., 24V DC or 110/230V AC.

6.4 OS client / OS server system with terminal server

In this configuration, the system has one OS server, one OS client and one separate ES.

In this example, the PCS 7 Web server and the terminal server are each configured on a separate PC.

Web servers and terminal servers can also be configured on a common PC.

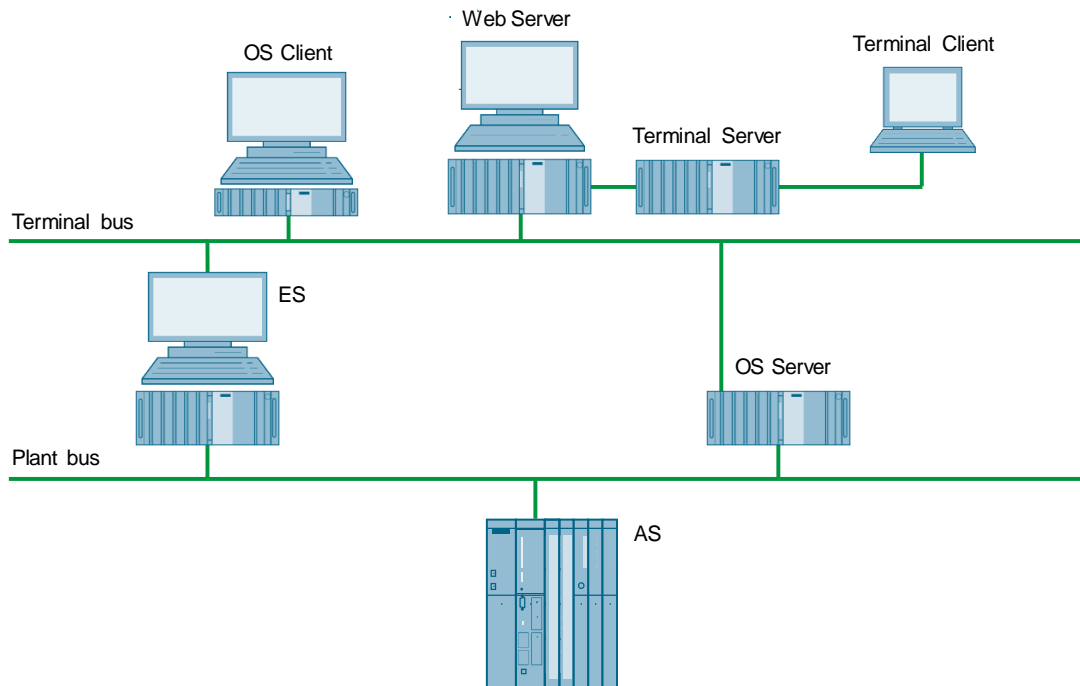

Bill of materials

Required	Optional	Article number	Product description	Note
Engineering Station				
1		6ES7660-6DA10-3BA0	SIMATIC PCS 7 INDUSTRIAL WORKSTATION IPC847D, CORE I5, ES/OS SINGLESTATION, 500 GB HD SATA, 8GB DDR3, BCE, PCS 7 V9.0, WINDOWS 10 ENTERPRISE 2015 LTSB 64BIT	
1		6ES7658-5AX58-0YA5	SOFTWARE SIMATIC PCS 7 AS/OS ENGINEERING V9.0	
	1	6ES7658-1CX58-2YA5	SOFTWARE SIMATIC PCS 7 VERSION CROSS MANAGER V9.0	
	1	6ES7658-1FX58-2YA5	SOFTWARE SIMATIC PCS 7 VERSION TRAIL V9.0	
	1	6ES7658-1DX58-2YB5	SOFTWARE SIMATIC PCS 7 IMPORT EXPORT ASSISTANT V9.0	
OS server				
1		6ES7660-6EC10-3EA0	SIMATIC PCS 7 INDUSTRIAL WORKSTATION IPC847D, CORE I5, OS-SERVER, RAID1 (2 X 1 TB HDD SATA, DATA MIRRORING), 8GB DDR3, BCE, PCS 7 V9.0, WIN SERVER 2012 R2 STANDARD EDITION INCL. 5 CLIENT 64BIT	
1		6ES7658-2BA58-0YA0	SOFTWARE SIMATIC PCS 7 OS-SERVER V9.0 (PO 100)	1)
OS client				
1		6ES7660-5FA08-2BA0	SIMATIC PCS 7 INDUSTRIAL WORKSTATION IPC647D, CORE I5, OS-CLIENT, 500 GB HD SATA, 4GB DDR3, PCS 7 V9.0, WINDOWS 10 ENTERPRISE 2015 LTSB 64 Bit	
1		6ES7658-2CX58-0YB5	SOFTWARE SIMATIC PCS 7 OS-CLIENT V9.0	
	1	6ES7652-0XD58-2YB5	SOFTWARE SIMATIC PCS 7 SFC VISUALIZATION V9.0	
Web server				
1		6ES7660-6EC10-3EA0	SIMATIC PCS 7 INDUSTRIAL WORKSTATION IPC847D, CORE I5, OS-SERVER, RAID1 (2 X 1 TB HDD SATA, DATA MIRRORING), 8GB DDR3, BCE, PCS 7 V9.0, WIN SERVER 2012 R2 STANDARD EDITION INCL. 5 CLIENT 64BIT	
1		6ES7658-2CX58-0YB5	SOFTWARE SIMATIC PCS 7 OS-CLIENT V9.0	
1		6ES7658-2GX58-2YB0	SOFTWARE SIMATIC PCS 7 WEB SERVER BASIC V9.0	
1		6ES7658-2GF00-0XB0	SOFTWARE SIMATIC PCS 7 WEB SERVER (5 CLIENTS)	2)

Required	Optional	Article number	Product description	Note
Terminal server				
1		6ES7660-6EC10-3EA0	SIMATIC PCS 7 INDUSTRIAL WORKSTATION IPC847D, CORE I5, OS-SERVER, RAID1 (2 X 1 TB HDD SATA, DATA MIRRORING), 8GB DDR3, BCE, PCS 7 V9.0, WIN SERVER 2012 R2 STANDARD EDITION INCL. 5 CLIENT 64BIT A Microsoft terminal server and a Web client are installed on this computer.	²⁾
Automation system				
1		6ES7654-6CN03-3BF0	SIMATIC PCS 7 SINGLE AS, CPU 410-5H, 1X DP- MODULE, 2x PROFINET-IO, SYSTEM EXPANSION CARD 1000 PO, AS RT PO 100, CP443-1IE, UR2 ALU RACK, 1 X UC 120/230V 10A POWER SUPPLY	³⁾
		24 V DC power supply	Redundant power supply	Chapter 17.2

Note

Laptops that are used as terminal clients are not listed. Wireless LAN that is used for laptop connection is not listed.

- ¹⁾ The number of POs can be increased later by means of extra volume licenses.
- ²⁾ The number of terminal clients can be increased by means of POWERPACKs.
- ³⁾ Please use the PCS 7 AS configurator, since different versions of the PCS 7 AS 410-5H are available; e. g., 24V DC or 110/230V AC.

6.5 OS client / OS server system with DataMonitor server

In this configuration, the system has one OS server, one OS client and one separate ES. The DataMonitor server is configured on a separate PC. The DataMonitor Clients have access to the DataMonitor server via a separate network.

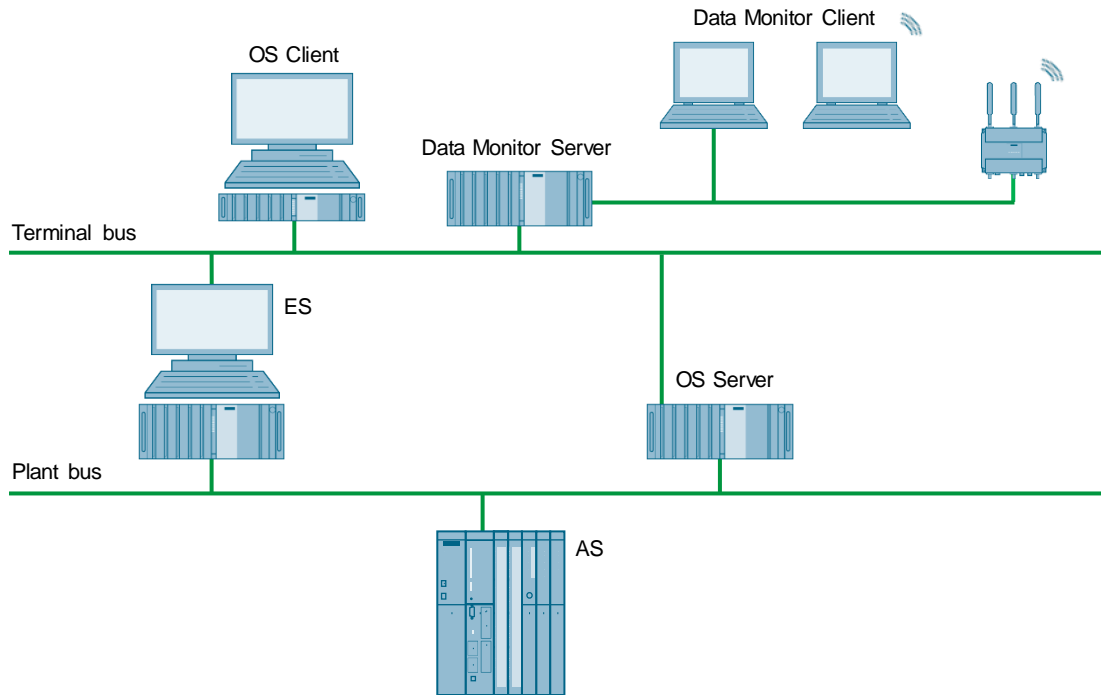

© Siemens AG 2019. All rights reserved

Bill of materials

Required	Optional	Article number	Product description	Note
Engineering Station				
1		6ES7660-6DA10-3BA0	SIMATIC PCS 7 INDUSTRIAL WORKSTATION IPC847D, CORE I5, ES/OS SINGLESTATION, 500 GB HD SATA, 8GB DDR3, BCE, PCS 7 V9.0, WINDOWS 10 ENTERPRISE 2015 LTSB 64BIT	
1		6ES7658-5AX58-0YA5	SOFTWARE SIMATIC PCS 7 AS/OS ENGINEERING V9.0	
	1	6ES7658-1CX58-2YA5	SOFTWARE SIMATIC PCS 7 VERSION CROSS MANAGER V9.0	
	1	6ES7658-1FX58-2YA5	SOFTWARE SIMATIC PCS 7 VERSION TRAIL V9.0	
	1	6ES7658-1DX58-2YB5	SOFTWARE SIMATIC PCS 7 IMPORT EXPORT ASSISTANT V9.0	

Required	Optional	Article number	Product description	Note
OS server				
1		6ES7660-6EC10-3EA0	SIMATIC PCS 7 INDUSTRIAL WORKSTATION IPC847D, CORE I5, OS-SERVER, RAID1 (2 X 1 TB HDD SATA, DATA MIRRORING), 8GB DDR3, BCE, PCS 7 V9.0, WIN SERVER 2012 R2 STANDARD EDITION INCL. 5 CLIENT 64BIT	
1		6ES7658-2BA58-0YA0	SOFTWARE SIMATIC PCS 7 OS-SERVER V9.0 (PO 100)	1)
OS client				
1		6ES7660-5FA08-3BA0	SIMATIC PCS 7 INDUSTRIAL WORKSTATION IPC647D, CORE I5, OS-CLIENT, 500 GB HD SATA, 4GB DDR3, PCS 7 V9.0, WINDOWS 10 ENTERPRISE 2015 LTSP 64 Bit	
1		6ES7658-2CX58-0YB5	SOFTWARE SIMATIC PCS 7 OS-CLIENT V9.0	
	1	6ES7652-0XD58-2YB5	SOFTWARE SIMATIC PCS 7 SFC VISUALIZATION V9.0	
DataMonitor server				
1		6ES7660-6EC10-3EA0	SIMATIC PCS 7 INDUSTRIAL WORKSTATION IPC847D, CORE I5, OS-SERVER, RAID1 (2 X 1 TB HDD SATA, DATA MIRRORING), 8GB DDR3, BCE, PCS 7 V9.0, WIN SERVER 2012 R2 STANDARD EDITION INCL. 5 CLIENT 64BIT	2)
1		6ES7658-2CX58-0YB5	SOFTWARE SIMATIC PCS 7 OS-CLIENT V9.0	
1		6AV6362-3AD00-0BB0	WINCC/DATAMONITOR, 3 CLIENT LICENCES (COUNTABLE), RUNTIME-SW	
Automation system				
1		6ES7654-6CN03-3BF0	SIMATIC PCS 7 SINGLE AS, CPU 410-5H, 1X DP-MODULE, 2x PROFINET-IO, SYSTEM EXPANSION CARD 1000 PO, AS RT PO 100, CP443-1IE, UR2 ALU RACK, 1 X UC 120/230V 10A POWER SUPPLY	3)
		24 V DC power supply	Redundant power supply	Chapter 17.2

Note

Laptops that are used as DataMonitoring clients are not listed. Wireless LAN that is used for laptop connection is not listed.

1) The number of POs can be increased later by means of extra volume licenses.

2) Installation of the DataMonitor server:

- Restore DVD (Windows Server 2012 R2)
- DataMonitor server software
- OS Client and DataMonitor server licenses

3) Please use the PCS 7 AS configurator, since different versions of the PCS 7 AS 410-5H are available; e. g., 24V DC or 110/230V AC.

6.6 OS client / OS server with Dual Monitor

In this configuration, the system has one OS server, two OS clients and one separate ES. The ES and the OS clients are each fitted with two monitors.

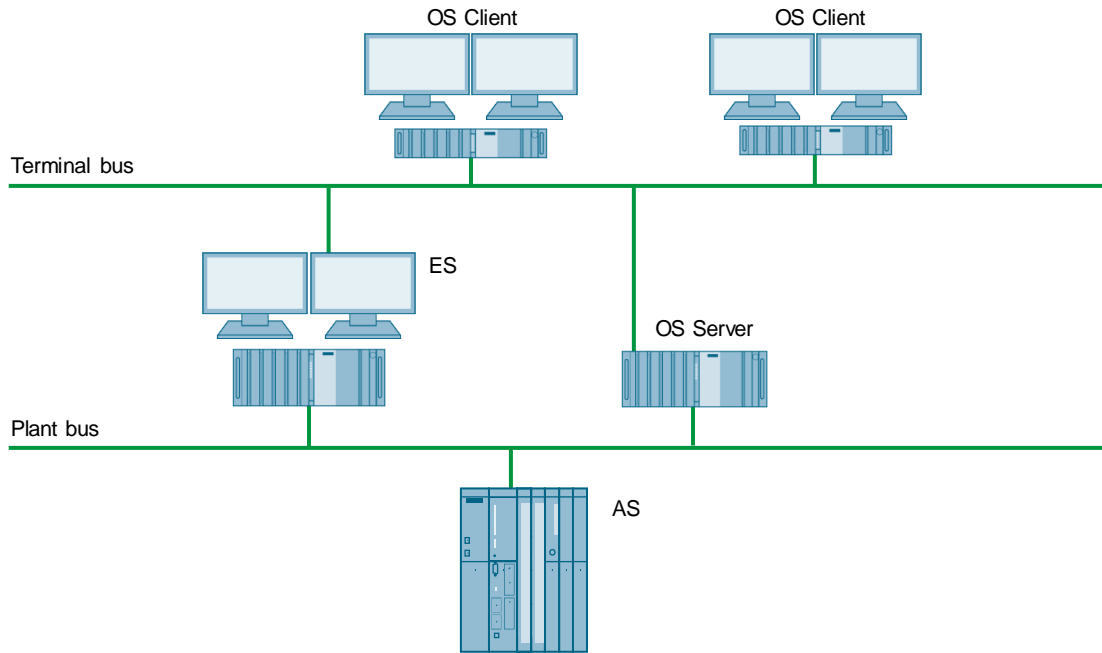

Bill of materials

Required	Optional	Article number	Product description	Note
Engineering Station				
1		6ES7660-6DC10-3BB0	SIMATIC PCS 7 INDUSTRIAL WORKSTATION IPC847D, CORE I5, ES/OS SINGLESTATION, RAID1 (2 x 1 TB HDD SATA, DATA MIRRORING), 8GB DDR3, MULTI MONITOR 2 SCREENS VIA ONBOARD INTERFACES (ADAPTER CABLE), BCE, PCS 7 V9.0, WINDOWS 10 ENTERPRISE 2015 LTSB 64BIT	
1		6ES7658-5AX58-0YA5	SOFTWARE SIMATIC PCS 7 AS/OS ENGINEERING V9.0	
	1	6ES7658-1CX58-2YA5	SOFTWARE SIMATIC PCS 7 VERSION CROSS MANAGER V9.0	
	1	6ES7658-1FX58-2YA5	SOFTWARE SIMATIC PCS 7 VERSION TRAIL V9.0	
	1	6ES7658-1DX58-2YB5	SOFTWARE SIMATIC PCS 7 IMPORT EXPORT ASSISTANT V9.0	

Required	Optional	Article number	Product description	Note
OS server				
1		6ES7660-6EC10-3EA0	SIMATIC PCS 7 INDUSTRIAL WORKSTATION IPC847D, CORE I5, OS-SERVER, RAID1 (2 X 1 TB HDD SATA, DATA MIRRORING), 8GB DDR3, BCE, PCS 7 V9.0, WIN SERVER 2012 R2 STANDARD EDITION INCL. 5 CLIENT 64BIT	
1		6ES7658-2BA58-0YA0	SOFTWARE SIMATIC PCS 7 OS-SERVER V9.0 (PO 100)	1)
OS client				
2		6ES7660-5FA08-2BB0	SIMATIC PCS 7 INDUSTRIAL WORKSTATION IPC647D, CORE I5, OS-CLIENT, 500 GB HDD SATA, 4GB DDR3, MULTI MONITOR 2 SCREENS VIA ONBOARD INTERFACES (ADAPTER CABLE), PCS 7 V9.0, WINDOWS 10 ENTERPRISE 2015 LTSB 64 Bit	
2		6ES7658-2CX58-0YB5	SOFTWARE SIMATIC PCS 7 OS-CLIENT V9.0	
	2	6ES7652-0XD58-2YB5	SOFTWARE SIMATIC PCS 7 SFC VISUALIZATION V9.0	
Automation system				
1		6ES7654-6CN03-3BF0	SIMATIC PCS 7 SINGLE AS, CPU 410-5H, 1X DP-MODULE, 2x PROFINET-IO, SYSTEM EXPANSION CARD 1000 PO, AS RT PO 100, CP443-1IE, UR2 ALU RACK, 1 X UC 120/230V 10A POWER SUPPLY	2)
		24 V DC power supply	Redundant power supply	Chapter 17.2

Note

¹⁾The number of POs can be increased later by means of extra volume licenses.

²⁾ Please use the PCS 7 AS configurator, since different versions of the PCS 7 AS 410-5H are available; e. g., 24V DC or 110/230V AC.

6.7 OS client / OS server system with multi user Engineering

In this configuration, the system has one OS server and three OS clients. One ES server and two ES clients ensure multi user engineering.

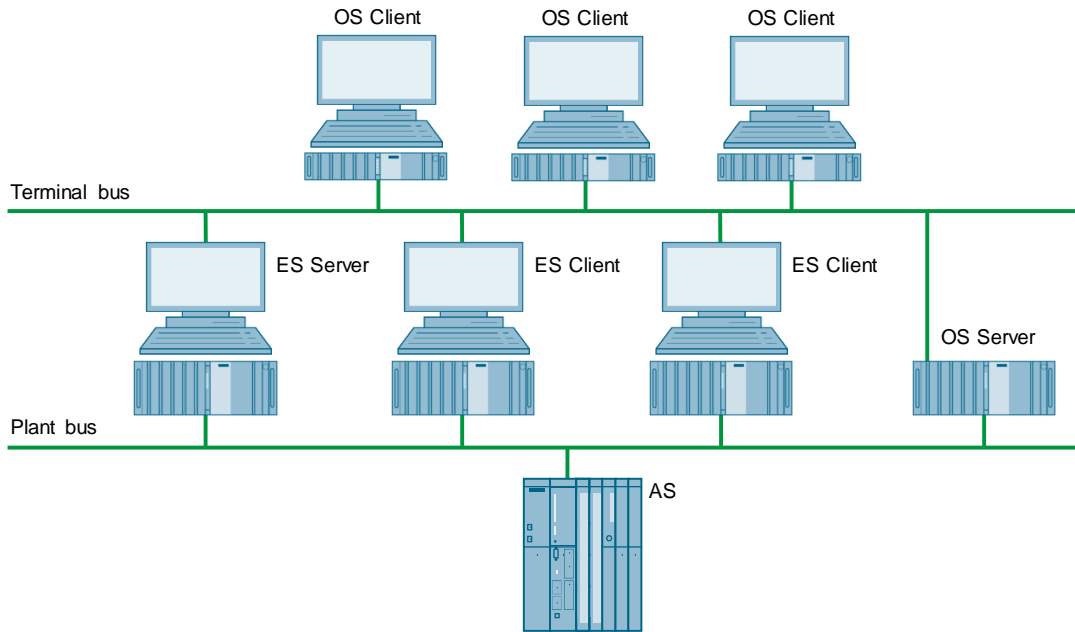

Bill of materials

Required	Optional	Article number	Product description	Note
ES server				
1		6ES7660-6EC10-3EA0	SIMATIC PCS 7 INDUSTRIAL WORKSTATION IPC847D, CORE I5, OS-SERVER, RAID1 (2 X 1 TB HDD SATA, DATA MIRRORING), 8GB DDR3, BCE, PCS 7 V9.0, WIN SERVER 2012 R2 STANDARD EDITION INCL. 5 CLIENT 64BIT	
1		6ES7658-5AX58-0YA5	SOFTWARE SIMATIC PCS 7 AS/OS ENGINEERING V9.0	
	1	6ES7658-1CX58-2YA5	SOFTWARE SIMATIC PCS 7 VERSION CROSS MANAGER V9.0	
	1	6ES7658-1FX58-2YA5	SOFTWARE SIMATIC PCS 7 VERSION TRAIL V9.0	
	1	6ES7658-1DX58-2YB5	SOFTWARE SIMATIC PCS 7 IMPORT EXPORT ASSISTANT V9.0	

Required	Optional	Article number	Product description	Note
ES client				
2		6ES7660-6DA10-3BA0	SIMATIC PCS 7 INDUSTRIAL WORKSTATION IPC847D, CORE I5, ES/OS SINGLESTATION, 500 GB HD SATA, 8GB DDR3, BCE, PCS 7 V9.0, WINDOWS 10 ENTERPRISE 2015 LTSB 64BIT	
2		6ES7658-5AX58-0YA5	SOFTWARE SIMATIC PCS 7 AS/OS ENGINEERING V9.0	
OS server				
1		6ES7660-6EC10-3EA0	SIMATIC PCS 7 INDUSTRIAL WORKSTATION IPC847D, CORE I5, OS-SERVER, RAID1 (2 X 1 TB HDD SATA, DATA MIRRORING), 8GB DDR3, BCE, PCS 7 V9.0, WIN SERVER 2012 R2 STANDARD EDITION INCL. 5 CLIENT 64BIT	
1		6ES7658-2BA58-0YA0	SOFTWARE SIMATIC PCS 7 OS-SERVER V9.0 (PO 100)	1)
OS client				
2		6ES7660-5FA08-3BA0	SIMATIC PCS 7 INDUSTRIAL WORKSTATION IPC647D, CORE I5, OS-CLIENT, 500 GB HD SATA, 4GB DDR3, PCS 7 V9.0, WINDOWS 10 ENTERPRISE 2015 LTSB 64 Bit	
2		6ES7658-2CX58-0YB5	SOFTWARE SIMATIC PCS 7 OS-CLIENT V9.0	
	2	6ES7652-0XD58-2YB5	SOFTWARE SIMATIC PCS 7 SFC VISUALIZATION V9.0	
Automation system				
1		6ES7654-6CN03-3BF0	SIMATIC PCS 7 SINGLE AS, CPU 410-5H, 1X DP-MODULE, 2x PROFINET-IO, SYSTEM EXPANSION CARD 1000 PO, AS RT PO 100, CP443-1IE, UR2 ALU RACK, 1 X UC 120/230V 10A POWER SUPPLY	2)
		24 V DC power supply	Redundant power supply	Chapter 17.2

Note

¹⁾ The number of POs can be increased later by means of extra volume licenses.

²⁾ Please use the PCS 7 AS configurator, since different versions of the PCS 7 AS 410-5H are available; e. g., 24V DC or 110/230V AC.

7 SIMATIC BATCH

SIMATIC BATCH

SIMATIC BATCH is the SIMATIC PCS 7 standard software for ISA-88 recipe management and batch management. SIMATIC BATCH is based on a scalable modular software that can be used in all SIMATIC PCS 7 architectures.

SIMATIC BATCH uses a standard client / server architecture with clients for recipe editing and batch control. SIMATIC BATCH clients can be installed on SIMATIC PCS 7 single user systems, server/client systems and PCs, on which no further SIMATIC PCS 7 software is available.

Single user system

The smallest system that supports SIMATIC BATCH is the single user station architecture. All SIMATIC BATCH software packages are installed on a single computer.

Client / server architecture

Mid-sized systems that support multiple users and do not need redundancy are implemented as client/server systems. SIMATIC BATCH follows the Operator Station architecture seamlessly by distributing the BATCH server and client applications to the corresponding Operator Station computers.

Client / server architecture (OS + SB combined)

When redundancy is required and the number of servers must be kept as low as possible, SIMATIC BATCH allows the operation of a redundant Batch server based on the redundant OS server pair PCs.

Client / server architecture redundant (OS + SB server separated)

When it comes to large, high-performance applications, the SIMATIC PCS 7 client / server architecture allows the distribution of applications across multiple PCs. In this case, the BATCH server and OS server run on two independent PCs. Each of them can be implemented on a redundant basis, as a result of which a very high level of availability is achieved. The OS client PCs can run the BATCH client application and access both the OS server and the BATCH server. If necessary, the OS client and BATCH client application can run on separate PCs as well.

7.1 SIMATIC BATCH single user system

This configuration is a system in which the ES, OS, and BATCH server and BATCH client are used on one PC as a single user system. The BATCH client must be installed and configured in addition to the BATCH server.

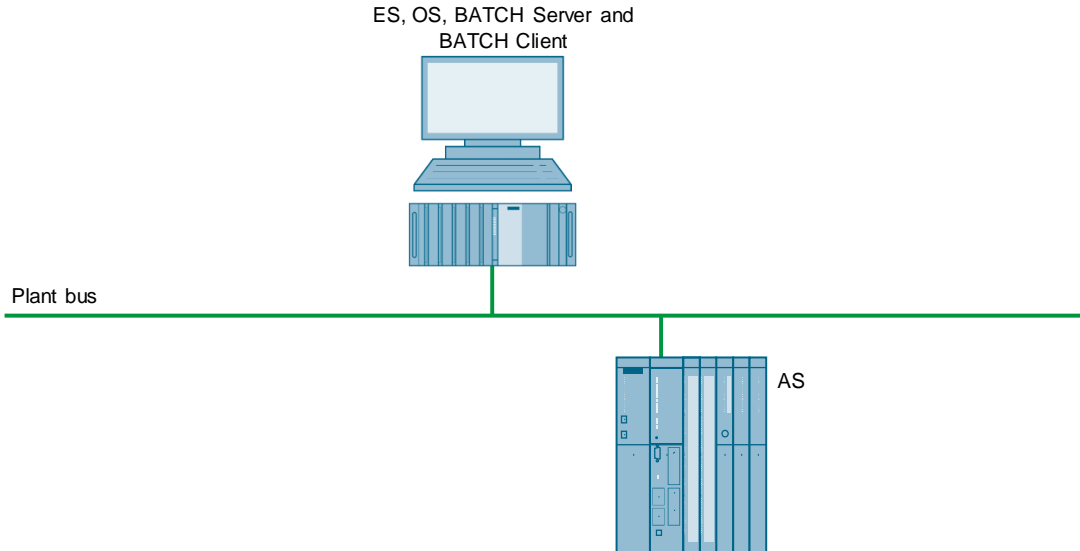

Bill of materials

Required	Optional	Article number	Product description	Note
Engineering Station, Operator Station, BATCH server and BATCH Client				
1		6ES7660-6DA10-3BA0	SIMATIC PCS 7 INDUSTRIAL WORKSTATION IPC847D, CORE I5, ES/OS SINGLESTATION, 500 GB HD SATA, 8GB DDR3, BCE, PCS 7 V9.0, WINDOWS 10 ENTERPRISE 2015 LTSB 64BIT	
1		6ES7651-5AA58-0YA0	SIMATIC PCS 7, SOFTWARE, ES SINGLE STATION V9.0 (AS/OS: 250 POs)	1)
	1	6ES7652-0XD58-2YB5	SOFTWARE SIMATIC PCS 7 SFC VISUALIZATION V9.0	
	1	6ES7658-1CX58-2YA5	SOFTWARE SIMATIC PCS 7 VERSION CROSS MANAGER V9.0	
	1	6ES7658-1DX58-2YB5	SOFTWARE SIMATIC PCS 7 IMPORT EXPORT ASSISTANT V9.0	
	1	6ES7658-1FX58-2YA5	SOFTWARE SIMATIC PCS 7 VERSION TRAIL V9.0	
1		6ES7657-0UX58-0YB0	SOFTWARE SIMATIC BATCH SINGLE STATION PACKAGE V9.0	
1		6ES7657-0XA00-0YB0	SOFTWARE SIMATIC BATCH (1 UNITS)	3)
1		6ES7657-0VX58-0YB5	SIMATIC BATCH CLIENT V9.0	

Required	Optional	Article number	Product description	Note
Automation system				
1		6ES7654-6CL03-3BF0	SIMATIC PCS 7 SINGLE AS, CPU 410-5H, SYSTEM EXPANSIONS CARD 500 PO, AS RT PO 100, CP443-1IE, UR2 ALU RACK, UC 120/230V 10A POWER SUPPLY	²⁾
		24 V DC power supply	Redundant power supply	Chapter 17.2

Note

- ¹⁾ The number of POs can be increased later by means of extra volume licenses.
- ²⁾ Please use the PCS 7 AS configurator, since different versions of the PCS 7 AS 410-5H are available; e. g., 24V DC or 110/230V AC.
- ³⁾ The number of batch units can be increased by means of cumulative batch unit licenses. The number of units is project-dependent.

7.2 SIMATIC BATCH single user system in an OS client / OS server architecture

In this example configuration, the system has two OS clients and two OS servers (the number of OS clients and OS servers may vary). The BATCH single station is configured as a single user system on a separate PC and may also include the BATCH client installation. However, separate SIMATIC BATCH clients are also possible with this example architecture.

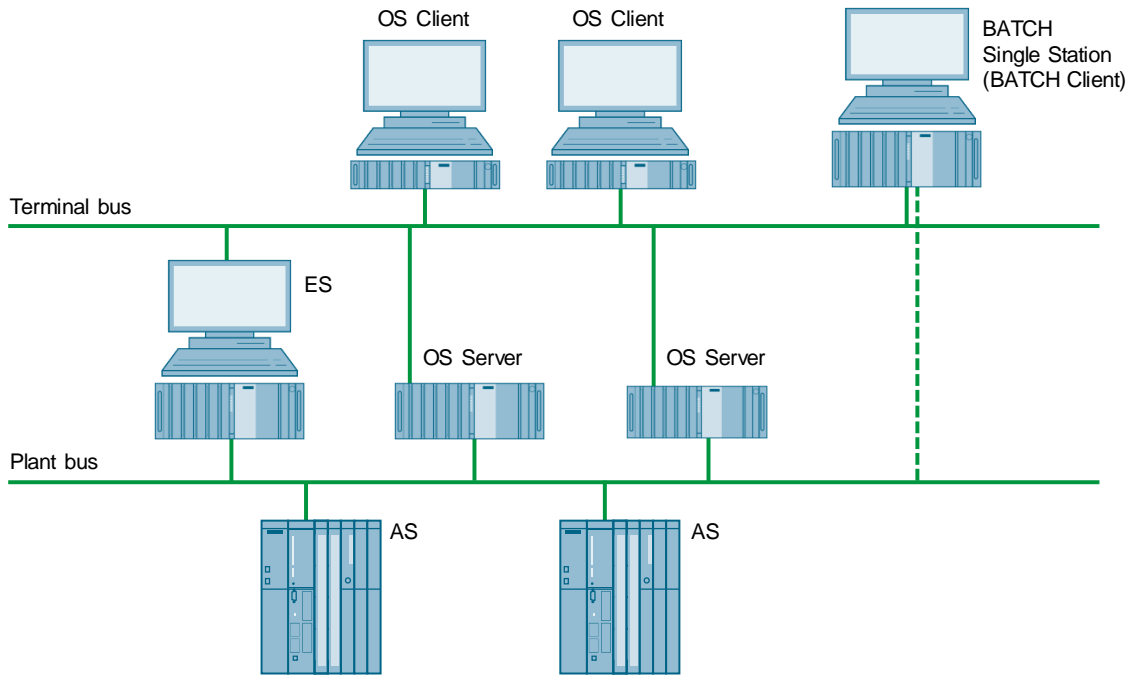

© Siemens AG 2019. All rights reserved.

Bill of materials

Required	Optional	Article number	Product description	Note
Engineering Station				
1		6ES7660-6DA10-3BA0	SIMATIC PCS 7 INDUSTRIAL WORKSTATION IPC847D, CORE I5, ES/OS SINGLESTATION, 500 GB HD SATA, 8GB DDR3, BCE, PCS 7 V9.0, WINDOWS 10 ENTERPRISE 2015 LTSB 64BIT	
1		6ES7658-5AX58-0YA5	SOFTWARE SIMATIC PCS 7 AS/OS ENGINEERING V9.0	
	1	6ES7658-1CX58-2YA5	SOFTWARE SIMATIC PCS 7 VERSION CROSS MANAGER V9.0	
	1	6ES7658-1DX58-2YB5	SOFTWARE SIMATIC PCS 7 IMPORT EXPORT ASSISTANT V9.0	
	1	6ES7658-1FX58-2YA5	SOFTWARE SIMATIC PCS 7 VERSION TRAIL V9.0	

7 SIMATIC BATCH

Required	Optional	Article number	Product description	Note
OS server				
2		6ES7660-6EC10-3EA0	SIMATIC PCS 7 INDUSTRIAL WORKSTATION IPC847D, CORE I5, OS-SERVER, RAID1 (2 X 1 TB HDD SATA, DATA MIRRORING), 8GB DDR3, BCE, PCS 7 V9.0, WIN SERVER 2012 R2 STANDARD EDITION INCL. 5 CLIENT 64BIT	
1		6ES7658-2BA58-0YA0	SOFTWARE SIMATIC PCS 7 OS-SERVER V9.0 (PO 100)	1)
OS client				
2		6ES7660-5FA08-3BA0	SIMATIC PCS 7 INDUSTRIAL WORKSTATION IPC647D, CORE I5, OS-CLIENT, 500 GB HD SATA, 4GB DDR3, PCS 7 V9.0, WINDOWS 10 ENTERPRISE 2015 LTSP LTSP 64BIT	
2		6ES7658-2CX58-0YB5	SOFTWARE SIMATIC PCS 7 OS-CLIENT V9.0	
	2	6ES7652-0XD58-2YB5	SOFTWARE SIMATIC PCS 7 SFC VISUALIZATION V9.0	
BATCH single station				
1		6ES7660-6DA10-3BA0	SIMATIC PCS 7 INDUSTRIAL WORKSTATION IPC847D, CORE I5, ES/OS SINGLESTATION, 500 GB HD SATA, 8GB DDR3, BCE, PCS 7 V9.0, WINDOWS 10 ENTERPRISE 2015 LTSP 64BIT	
1		6ES7657-0UX58-0YB0	SOFTWARE SIMATIC BATCH SINGLE STATION PACKAGE V9.0	
1		6ES7657-0XA00-0YB0	SOFTWARE SIMATIC BATCH (1 UNIT)	3)
BATCH client station (optional)				
	1	6ES7657-0VX58-0YB5	SIMATIC BATCH CLIENT V9.0	
Automation system				
2		6ES7654-6CN03-3BF0	SIMATIC PCS 7 SINGLE AS, CPU 410-5H, 1X DP-MODULE, 2x PROFINET-IO, SYSTEM EXPANSION CARD 1000 PO, AS RT PO 100, CP443-1IE, UR2 ALU RACK, 1 X UC 120/230V 10A POWER SUPPLY	2)
		24 V DC power supply	Redundant power supply	Chapter 17.2

Note

- 1) The number of POs can be increased later by means of extra volume licenses.
- 2) Please use the PCS 7 AS configurator, since different versions of the PCS 7 AS 410-5H are available; e. g., 24V DC or 110/230V AC.
- 3) The number of batch units can be increased by means of cumulative batch unit licenses. The number of units is project-dependent.

7.3 SIMATIC BATCH OS client / OS server

This example configuration is a system with three BATCH clients installed on the OS clients and a separate ES. The OS server and BATCH server are integrated on a common PC.

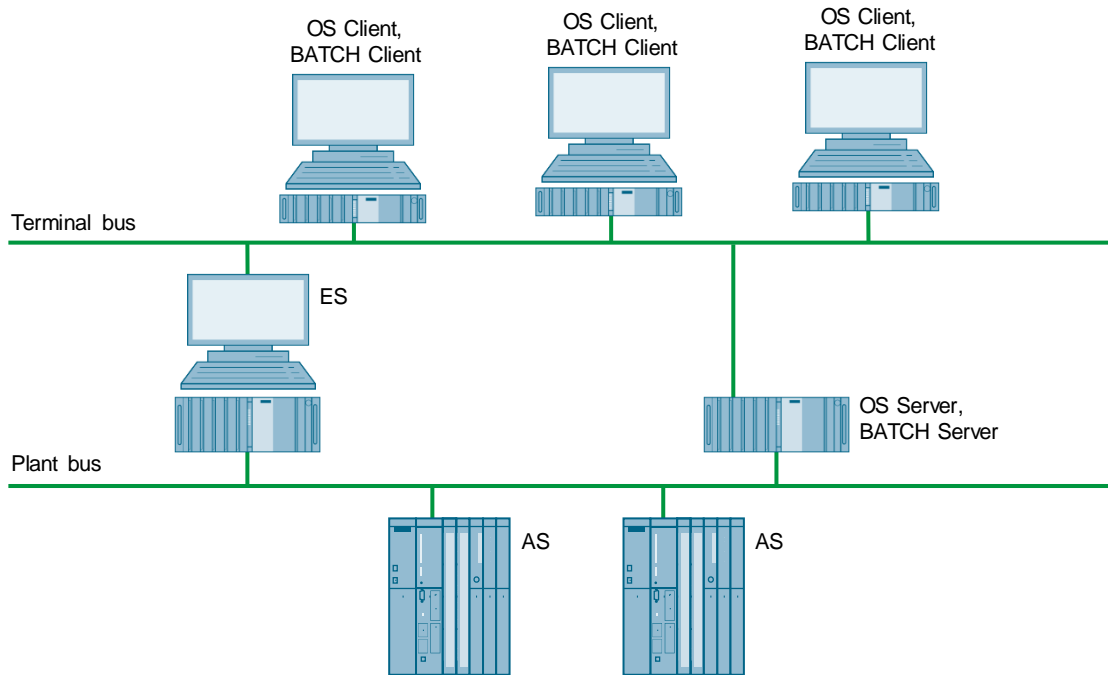

© Siemens AG 2019. All rights reserved

Bill of materials

Required	Optional	Article number	Product description	Note
Engineering Station				
1		6ES7660-6DA10-3BA0	SIMATIC PCS 7 INDUSTRIAL WORKSTATION IPC847D, CORE I5, ES/OS SINGLESTATION, 500 GB HD SATA, 8GB DDR3, BCE, PCS 7 V9.0, WINDOWS 10 ENTERPRISE 2015 LTSB 64BIT	
1		6ES7658-5AX58-0YA5	SOFTWARE SIMATIC PCS 7 AS/OS ENGINEERING V9.0	
	1	6ES7658-1CX58-2YA5	SOFTWARE SIMATIC PCS 7 VERSION CROSS MANAGER V9.0	
	1	6ES7658-1FX58-2YA5	SOFTWARE SIMATIC PCS 7 VERSION TRAIL V9.0	
	1	6ES7658-1DX58-2YB5	SOFTWARE SIMATIC PCS 7 IMPORT EXPORT ASSISTANT V9.0	

7 SIMATIC BATCH

Required	Optional	Article number	Product description	Note
OS server, BATCH server				
1		6ES7660-6EC10-3EA0	SIMATIC PCS 7 INDUSTRIAL WORKSTATION IPC847D, CORE I5, OS-SERVER, RAID1 (2 X 1 TB HDD SATA, DATA MIRRORING), 8GB DDR3, BCE, PCS 7 V9.0, WIN SERVER 2012 R2 STANDARD EDITION INCL. 5 CLIENT 64BIT	
1		6ES7658-2BA58-0YA0	SOFTWARE SIMATIC PCS 7 OS-SERVER V9.0 (PO 100)	1)
1		6ES7657-0TX58-0YB0	SOFTWARE SIMATIC BATCH SERVER V9.0	
1		6ES7657-0XB00-0YB0	SOFTWARE SIMATIC BATCH (10 UNITS)	3)
OS client, BATCH client				
3		6ES7660-5FA08-3BA0	SIMATIC PCS 7 INDUSTRIAL WORKSTATION IPC647D, CORE I5, OS-CLIENT, 500 GB HD SATA, 4GB DDR3, PCS 7 V9.0, WINDOWS 10 ENTERPRISE 2015 LTSC 64BIT	
3		6ES7658-2CX58-0YB5	SOFTWARE SIMATIC PCS 7 OS-CLIENT V9.0	
	3	6ES7652-0XD58-2YB5	SOFTWARE SIMATIC PCS 7 SFC VISUALIZATION V9.0	
3		6ES7657-0VX58-0YB5	SOFTWARE SIMATIC BATCH CLIENT V9.0	
1	2	6ES7657-0AX58-0YB5	SOFTWARE SIMATIC BATCH RECIPE SYSTEM V9.0	4)
Automation system				
2		6ES7654-6CN03-3BF0	SIMATIC PCS 7 SINGLE AS, CPU 410-5H, 1X DP-MODULE, 2x PROFINET-IO, SYSTEM EXPANSION CARD 1000 PO, AS RT PO 100, CP443-1IE, UR2 ALU RACK, 1 X UC 120/230V 10A POWER SUPPLY	2)
		24 V DC power supply	Redundant power supply	Chapter 17.2

Note

- 1) The number of POs can be increased later by means of extra volume licenses.
- 2) Please use the PCS 7 AS configurator, since different versions of the PCS 7 AS 410-5H are available; e. g., 24V DC or 110/230V AC.
- 3) The number of batch units can be increased by means of cumulative batch unit licenses. The number of units is project-dependent.
- 4) The SIMATIC BATCH recipe system license is needed on at least one of the clients in a client server system (on all the clients that are to be used to create and edit recipes).

7.4 Separate SIMATIC BATCH server

In this example configuration, the system has two OS clients and two OS servers, two BATCH clients and two OS servers. The BATCH server is configured on a separate PC.

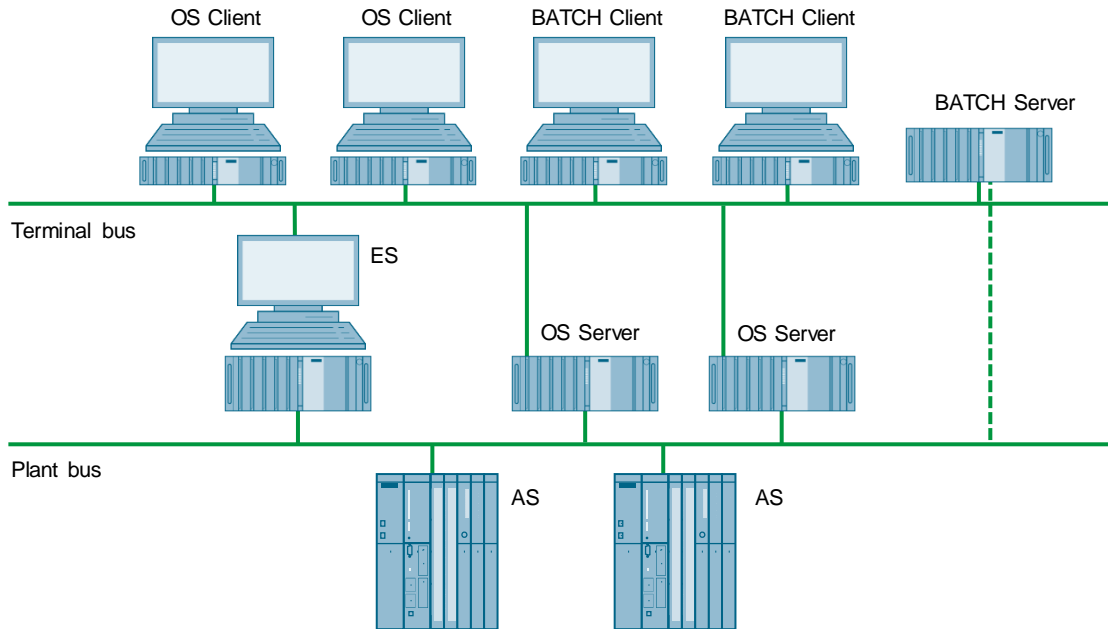

Bill of materials

Required	Optional	Article number	Product description	Note
Engineering Station				
1		6ES7660-6DA10-3BA0	SIMATIC PCS 7 INDUSTRIAL WORKSTATION IPC847D, CORE I5, ES/OS SINGLESTATION, 500 GB HD SATA, 8GB DDR3, BCE, PCS 7 V9.0, WINDOWS 10 ENTERPRISE 2015 LTSB 64BIT	
1		6ES7658-5AX58-0YA5	SOFTWARE SIMATIC PCS 7 AS/OS ENGINEERING V9.0	
	1	6ES7658-1CX58-2YA5	SOFTWARE SIMATIC PCS 7 VERSION CROSS MANAGER V9.0	
	1	6ES7658-1FX58-2YA5	SOFTWARE SIMATIC PCS 7 VERSION TRAIL V9.0	
	1	6ES7658-1DX58-2YB5	SOFTWARE SIMATIC PCS 7 IMPORT EXPORT ASSISTANT V9.0	
OS server				
2		6ES7660-6EC10-3EA0	SIMATIC PCS 7 INDUSTRIAL WORKSTATION IPC847D, CORE I5, OS-SERVER, RAID1 (2 X 1 TB HDD SATA, DATA MIRRORING), 8GB DDR3, BCE, PCS 7 V9.0, WIN SERVER 2012 R2 STANDARD EDITION INCL. 5 CLIENT 64BIT	
2		6ES7658-2BA58-0YA0	SOFTWARE SIMATIC PCS 7 OS-SERVER V9.0 (PO 100)	1)
BATCH server				
1		6ES7660-6EC10-3EA0	SIMATIC PCS 7 INDUSTRIAL WORKSTATION IPC847D, CORE I5, OS-SERVER, RAID1 (2 X 1 TB HDD SATA, DATA MIRRORING), 8GB DDR3, BCE, PCS 7 V9.0, WIN SERVER 2012 R2 STANDARD EDITION INCL. 5 CLIENT 64BIT	
1		6ES7657-0TX58-0YB0	SOFTWARE SIMATIC BATCH SERVER V9.0	
1		6ES7657-0XB00-0YB0	SOFTWARE SIMATIC BATCH (10 UNITS)	3)
OS client				
2		6ES7660-5FA08-3BA0	SIMATIC PCS 7 INDUSTRIAL WORKSTATION IPC647D, CORE I5, OS-CLIENT, 500 GB HD SATA, 4GB DDR3, PCS 7 V9.0, WINDOWS 10 ENTERPRISE 2015 LTSB 64BIT	
2		6ES7658-2CX58-0YB5	SOFTWARE SIMATIC PCS 7 OS-CLIENT V9.0	
	2	6ES7652-0XD58-2YB5	SOFTWARE SIMATIC PCS 7 SFC VISUALIZATION V9.0	
Batch client				
2		6ES7660-5FA08-3BA0	SIMATIC PCS 7 INDUSTRIAL WORKSTATION IPC647D, CORE I5, OS-CLIENT, 500 GB HD SATA, 4GB DDR3, PCS 7 V9.0, WINDOWS 10 ENTERPRISE 2015 LTSB 64BIT	
2		6ES7657-0VX58-0YB5	SOFTWARE SIMATIC BATCH CLIENT V9.0	
1	1	6ES7657-0AX58-0YB5	SOFTWARE SIMATIC BATCH RECIPE SYSTEM V9.0	4)

Required	Optional	Article number	Product description	Note
Automation system				
2		6ES7654-6CN03-3BF0	SIMATIC PCS 7 SINGLE AS, CPU 410-5H, 1X DP-MODULE, 2x PROFINET-IO, SYSTEM EXPANSION CARD 1000 PO, AS RT PO 100, CP443-1IE, UR2 ALU RACK, 1 X UC 120/230V 10A POWER SUPPLY	2)
		24 V DC power supply	Redundant power supply	Chapter 17.2

Note

- 1) The number of POs can be increased later by means of extra volume licenses.
- 2) Please use the PCS 7 AS configurator, since different versions of the PCS 7 AS 410-5H are available; e. g., 24V DC or 110/230V AC.
- 3) The number of batch units can be increased by means of cumulative batch unit licenses. The number of units is project-dependent.
- 4) The SIMATIC BATCH recipe system license is needed on at least one of the clients in a client server system (on all the clients that are to be used to create and edit recipes).

7.5 Redundant SIMATIC BATCH client / server architecture

This example configuration is a system with a redundant BATCH server pair and two BATCH clients, which are installed together with the OS clients on one computer. The ES is configured on a separate PC. The terminal bus and the plant bus are also set up on a redundant basis.

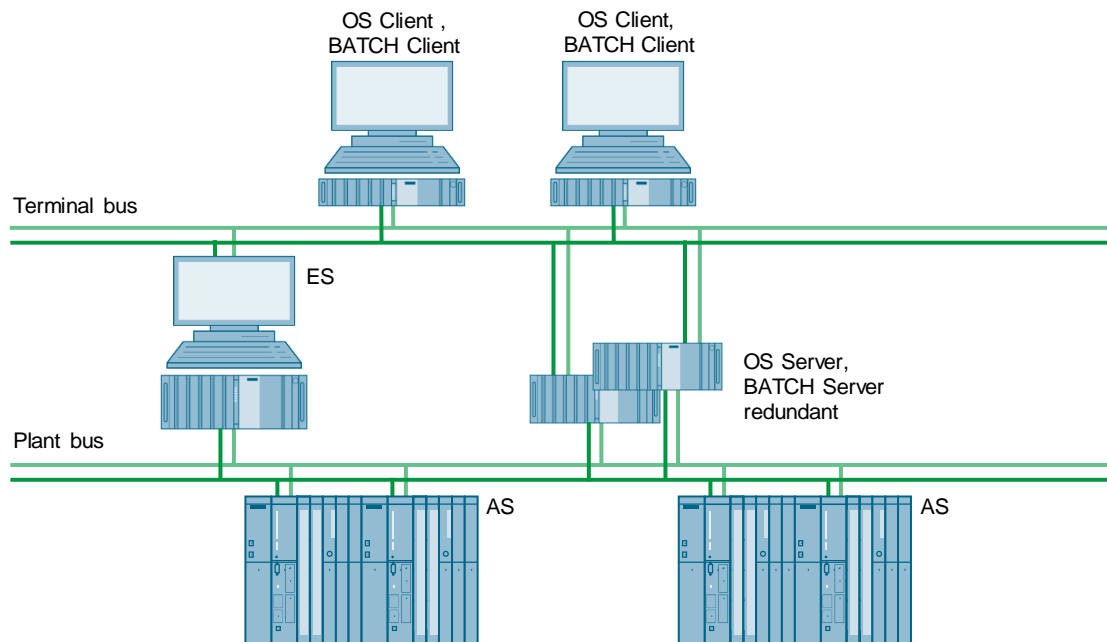

Bill of materials

Required	Optional	Article number	Product description	Note
Engineering Station				
1		6ES7660-6DF21-3BA0	SIMATIC PCS 7 INDUSTRIAL WORKSTATION IPC847D, CORE I5, ES/OS SINGLESTATION, RAID1 (2 X 1 TB HDD SATA, DATA MIRRORING), 16GB DDR3, INDUSTRIAL ETHERNET (CP1623), PCS 7 V9.0, WINDOWS 10 ENTERPRISE 2015 LTSB 64BIT	
1		6ES7658-5AX58-0YA5	SOFTWARE SIMATIC PCS 7 AS/OS ENGINEERING V9.0	
1		6GK1162-3AA00	SIMATIC NET COMMUNICATION PROCESSOR CP 1623 PCI EXPRESS	1)
1		6GK1716-0HB14-0AC0	SIMATIC NET, S7-REDCONNECT POWERPACK V14	3)
1		6GK1711-1EW14-0AA0	SIMATIC NET SOFTNET-IE RNA V14 REDUNDANT NETWORK ACCESS	8)
	1	6ES7658-1CX58-2YA5	SOFTWARE SIMATIC PCS 7 VERSION CROSS MANAGER V9.0	
	1	6ES7658-1FX58-2YA5	SOFTWARE SIMATIC PCS 7 VERSION TRAIL V9.0	
	1	6ES7658-1DX58-2YB5	SOFTWARE SIMATIC PCS 7 IMPORT EXPORT ASSISTANT V9.0	
OS server, BATCH server				
2		6ES7660-6EF21-3EA0	SIMATIC PCS 7 INDUSTRIAL WORKSTATION IPC847D, CORE I5, OS-SERVER, RAID1 (2 X 1 TB HDD SATA, DATA MIRRORING), 16GB DDR3, INDUSTRIAL ETHERNET (CP1623), PCS 7 V9.0, WINDOWS SERVER 2012 R2 STANDARD EDITION, 64 BIT	
1		6ES7652-3BA58-2YA0	SOFTWARE SIMATIC PCS 7 OS-SERVER REDUNDANCY V9.0 (PO 100)	2)
2		6GK1162-3AA00	SIMATIC NET COMMUNICATION PROCESSOR CP 1623 PCI EXPRESS	1)
2		6GK1716-0HB14-0AC0	SIMATIC NET, S7-REDCONNECT POWERPACK V14	3)
2		6GK1711-1EW14-0AA0	SIMATIC NET SOFTNET-IE RNA V14 REDUNDANT NETWORK ACCESS	8)
2		A5E02639550	DESKTOP ADAPTER NETWORK CARD	6)
1		6XV1870-3RH60	SIMATIC NET INDUSTRIAL ETHERNET TP XP CORD RJ45/RJ45, 6M	
2		6ES7657-0TX58-0YB0	SOFTWARE SIMATIC BATCH SERVER V9.0	
2		6ES7657-0XB00-0YB0	SOFTWARE SIMATIC BATCH (10 UNITS)	5)

Required	Optional	Article number	Product description	Note
OS client, BATCH client				
2		6ES7660-5FA08-3BA0	SIMATIC PCS 7 INDUSTRIAL WORKSTATION IPC647D, CORE I5, OS-CLIENT, 500 GB HD SATA, 4GB DDR3, PCS 7 V9.0, WINDOWS 10 ENTERPRISE 2015 LTSB 64 Bit	
2		6ES7658-2CX58-0YB5	SOFTWARE SIMATIC PCS 7 OS-CLIENT V9.0	
2		6GK1711-1EW14-0AA0	SIMATIC NET SOFTNET-IE RNA V14 REDUNDANT NETWORK ACCESS	8)
	2	6ES7652-0XD58-2YB5	SOFTWARE SIMATIC PCS 7 SFC VISUALIZATION V9.0	
2		6ES7657-0VX58-0YB5	SOFTWARE SIMATIC BATCH CLIENT V9.0	
1	1	6ES7657-0AX58-0YB5	SOFTWARE SIMATIC BATCH RECIPE SYSTEM V9.0	7)
Automation system				
2		6ES7656-6CN33-1CF0	SIMATIC PCS 7 REDUNDANCY AS, 2X CPU 410-5H, 2 DP-MODULES, 2X PROFINET-IO, SYSTEM EXPANSION CARD 1000 PO, AS RT PO 100, 2 X 2 10M SYNC-MODULES AND 2 X 1M FO, 2 X CP443-1	4)
		24 V DC power supply	Redundant power supply	Chapter 17.2

Note

- 1) Needed if a redundant system bus is chosen.
 - 2) The number of POs can be increased later by means of extra volume licenses.
 - 3) Necessary if a redundant system bus or a redundant automation system is chosen.
 - 4) Please use the PCS 7 AS configurator, since different versions of the PCS 7 AS 410-5H are available; e. g., 24V DC or 110/230V AC.
 - 5) The number of batch units can be increased by means of cumulative batch unit licenses. The number of units is project-dependent.
 - 6) Additional network cards are required for redundancy switching.
 - 7) The SIMATIC BATCH recipe system license is needed on at least one of the clients in a client server system (on all the clients that are to be used to create and edit recipes).
 - 8) The onboard interfaces can be used.
- Single license for one installation. Necessary if a redundant terminal bus is selected.

7.6 SIMATIC BATCH client / server architecture redundant (OS + SB server separated)

In this example configuration, the system has one redundant BATCH server pair and two redundant OS server pairs. The five SIMATIC BATCH clients are combined with the five OS clients. This ES is a separate PC.

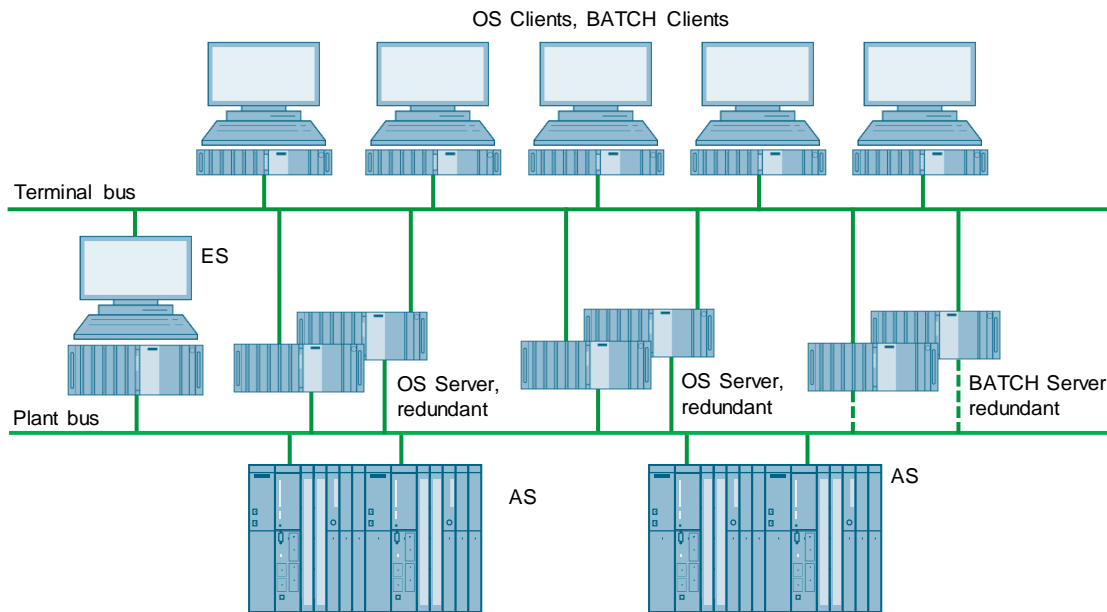

Bill of materials

Required	Optional	Article number	Product description	Note
Engineering Station				
1		6ES7660-6DF11-3BA0	SIMATIC PCS 7 INDUSTRIAL WORKSTATION IPC847D, CORE I5, ES/OS SINGLESTATION, RAID1 (2 X 1 TB HDD SATA, DATA MIRRORING), 8GB DDR3, INDUSTRIAL ETHERNET (CP1623), PCS 7 V9.0, WINDOWS 10 ENTERPRISE 2015 LTSB 64BIT	
1		6ES7658-5AX58-0YA5	SOFTWARE SIMATIC PCS 7 AS/OS ENGINEERING V9.0	
	1	6ES7658-1CX58-2YA5	SOFTWARE SIMATIC PCS 7 VERSION CROSS MANAGER V9.0	
	1	6ES7658-1FX58-2YA5	SOFTWARE SIMATIC PCS 7 VERSION TRAIL V9.0	
	1	6ES7658-1DX58-2YB5	SOFTWARE SIMATIC PCS 7 IMPORT EXPORT ASSISTANT V9.0	
OS server				
4		6ES7660-6EF21-3EA0	SIMATIC PCS 7 INDUSTRIAL WORKSTATION IPC847D, CORE I5, OS-SERVER, RAID1 (2 X 1 TB HDD SATA, DATA MIRRORING), 16GB DDR3, INDUSTRIAL ETHERNET (CP1623), PCS 7 V9.0, WINDOWS SERVER 2012 R2 STANDARD EDITION, 64 BIT	
4		6GK1716-0HB14-0AC0	SIMATIC NET, S7-REDCONNECT POWERPACK V14	1)
2		6ES7652-3BA58-2YA0	SOFTWARE SIMATIC PCS 7 OS-SERVER REDUNDANCY V9.0 (PO 100)	2) 7)
BATCH server				
2		6ES7660-6EC10-3EA0	SIMATIC PCS 7 INDUSTRIAL WORKSTATION IPC847D, CORE I5, OS-SERVER, RAID1 (2 X 1 TB HDD SATA, DATA MIRRORING), 8GB DDR3, BCE, PCS 7 V9.0, WIN SERVER 2012 R2 STANDARD EDITION INCL. 5 CLIENT 64BIT	
2		A5E02639550	DESKTOP ADAPTER NETWORK CARD	5)
1		6XV1870-3RH60	SIMATIC NET INDUSTRIAL ETHERNET TP XP CORD RJ45/RJ45, 6M	
2		6ES7657-0TX58-0YB0	SOFTWARE SIMATIC BATCH SERVER V9.0	
2		6ES7657-0XB00-0YB0	SOFTWARE SIMATIC BATCH (10 UNITS)	4)
OS client, BATCH client				
5		6ES7660-5FA08-3BA0	SIMATIC PCS 7 INDUSTRIAL WORKSTATION IPC647D, CORE I5, OS-CLIENT, 500 GB HD SATA, 4GB DDR3, PCS 7 V9.0, WINDOWS 10 ENTERPRISE 2015 LTSB 64 Bit	
5		6ES7658-2CX58-0YB5	SOFTWARE SIMATIC PCS 7 OS-CLIENT V9.0	
	5	6ES7652-0XD58-2YB5	SOFTWARE SIMATIC PCS 7 SFC VISUALIZATION V9.0	
2	³	6ES7657-0VX58-0YB5	SOFTWARE SIMATIC BATCH CLIENT V9.0	
1	4	6ES7657-0AX58-0YB5	SOFTWARE SIMATIC BATCH RECIPE SYSTEM V9.0	6)

Required	Optional	Article number	Product description	Note
Automation system				
2		6ES7656-6CQ33-1CF0	SIMATIC PCS 7 REDUNDANCY AS, 2X CPU 410-5H, 2 DP-MODULE, 2X PROFINET-IO, SYSTEM EXPANSION CARD 2k+ PO, AS RT PO 100, 2 X 2 10M SYNC-MODULE AND 2 X 1M FO, 2 X CP443-1 IE/PN, 1 X UR2-H ALU RACK, 2 X UC 120/230V 10A RED. POWER SUPPLY	³⁾
		24 V DC power supply	Redundant power supply	Chapter 17.2

Note

- 1) Needed for a redundant automation system.
- 2) The number of POs can be increased later by means of extra volume licenses.
- 3) Please use the PCS 7 AS configurator, since different versions of the PCS 7 AS 410-5H are available; e. g., 24V DC or 110/230V AC.
- 4) The number of batch units can be increased by means of cumulative BATCH unit licenses. The number of units is project-dependent.
- 5) The second network card is used for redundancy switching.
- 6) The SIMATIC BATCH recipe system license is needed on at least one of the clients in a client server system (on all the clients that are to be used to create and edit recipes).
- 7) The redundant OS server pair is supplied with an RS-232 serial connection cable. If there is a long distance between the redundant systems, you can use an Ethernet connection instead. This requires additional Ethernet network interface cards in the systems.

8 SIMATIC Route Control

SIMATIC Route Control

SIMATIC Route Control is an optional package of the SIMATIC PCS 7 process control system and is integrated into the PCS 7 engineering and runtime system. Route Control is a system for automatic or manual control of material transport (routes) in process plants.

Simple transport processes right up to comprehensive route combinations are possible at runtime. Plant operators only need to specify the source and target locations for the route request. Route Control allows users to determine, check, control and monitor transport routes and the route elements they contain.

Single user system

The smallest system that supports all SIMATIC Route Control functions is the Single Station. Route Control engineering, server, client and the functionality of the automation system are all installed on one PC and run in-parallel with the operator station.

Client / server architecture

Mid-sized systems that support multiple users and require no redundancy are implemented as client / server systems. SIMATIC Route Control scales seamlessly to the Operator Station architecture by distributing the Route Control server and client applications to the corresponding Operator station PCs.

Client / server architecture redundant (OS + RCS combined)

When redundancy is required and the number of servers must be kept as small as possible, SIMATIC Route Control allows the operation of a redundant Route Control server based on the redundant OS server pair.

Client / server architecture redundant (OS + RCS separated)

For large and high-performance applications, the SIMATIC PCS 7 client / server architecture allows the distribution of applications across multiple PCs. In this case, the Route Control Server and OS server run on two independent PCs. Each of them can be configured redundantly, as a result of which high level of availability is achieved. The OS client PCs can access both the OS server and the Route Control server. If necessary, both the OS client and the Route Control client application can run on separate PCs.

8.1 SIMATIC Route Control single user system

This configuration is a system in which the ES, OS and Route Control server are used on one PC as a single user system.

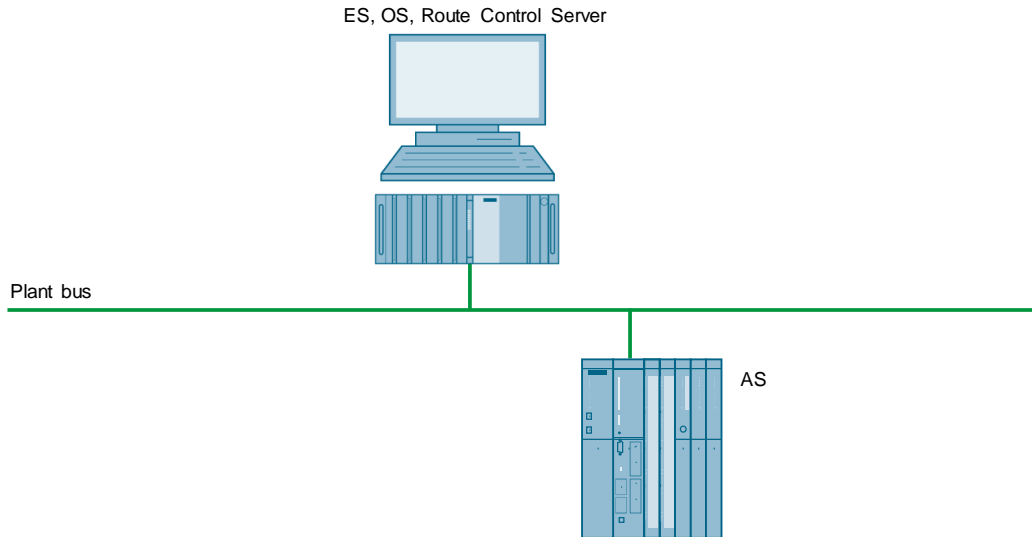

Bill of materials

Required	Optional	Article number	Product description	Note
Engineering Station, Operator Station and Route Control server				
1		6ES7660-6DA10-3BA0	SIMATIC PCS 7 INDUSTRIAL WORKSTATION IPC847D, CORE I5, ES/OS SINGLESTATION, 500 GB HD SATA, 8GB DDR3, BCE, PCS 7 V9.0, WINDOWS 10 ENTERPRISE 2015 LTSP 64BIT	
1		6ES7651-5AA58-0YA0	SIMATIC PCS 7, SOFTWARE, ES SINGLE STATION V9.0 (AS/OS: 250 POs)	1)
	1	6ES7652-0XD58-2YB5	SOFTWARE SIMATIC PCS 7 SFC VISUALIZATION V9.0	
	1	6ES7658-1CX58-2YA5	SOFTWARE SIMATIC PCS 7 VERSION CROSS MANAGER V9.0	
	1	6ES7658-1DX58-2YB5	SOFTWARE SIMATIC PCS 7 IMPORT EXPORT ASSISTANT V9.0	
	1	6ES7658-1FX58-2YA5	SOFTWARE SIMATIC PCS 7 VERSION TRAIL V9.0	

Required	Optional	Article number	Product description	Note
1		6ES7658-7DX58-0YB5	SOFTWARE SIMATIC ROUTE CONTROL ENGINEERING V9.0	
1		6ES7658-7FX58-0YB0	SOFTWARE SIMATIC ROUTE CONTROL SERVER V9.0	
1		6ES7658-7FF00-0XB0	SOFTWARE SIMATIC ROUTE CONTROL (10 ROUTES)	³⁾
1		6ES7658-7EX58-0YB5	SOFTWARE SIMATIC ROUTE CONTROL CENTER V9.0	
Automation system				
1		6ES7654-6CL03-3BF0	SIMATIC PCS 7 SINGLE AS, CPU 410-5H, SYSTEM EXPANSIONS CARD 500 PO, AS RT PO 100, CP443-1IE, UR2 ALU RACK, UC 120/230V 10A POWER SUPPLY	²⁾
		24 V DC power supply	Redundant power supply	Chapter 17.2

Note

- ¹⁾ The number of POs can be increased later by means of extra volume licenses.
- ²⁾ Please use the PCS 7 AS configurator, since different versions of the PCS 7 AS 410-5H are available; e. g., 24V DC or 110/230V AC.
- ³⁾ At least one SIMATIC Route Control Routes license (for sets of 10/50) is required per project. The number of routes can be increased at a later stage with cumulative SIMATIC Route Control Routes Licenses.

8.2 SIMATIC Route Control client / server architecture

In this example configuration, the system has three Route Control clients and one separate ES. The OS server and the Route Control server are integrated on one PC.

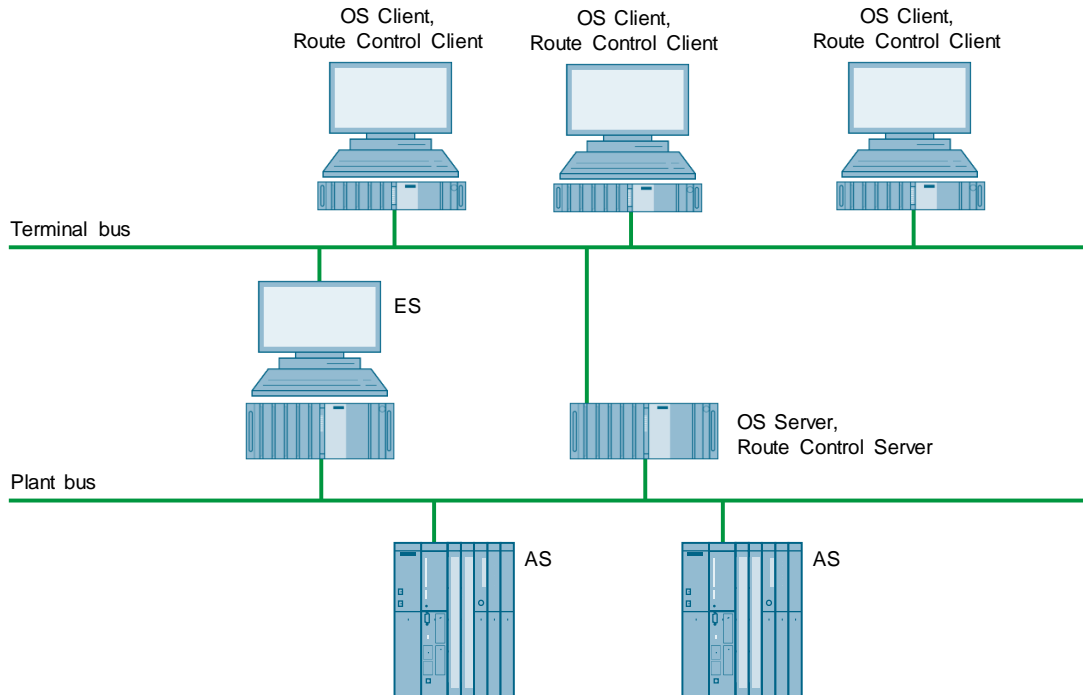

Bill of materials

Required	Optional	Article number	Product description	Note
Engineering Station				
1		6ES7660-6DA10-3BA0	SIMATIC PCS 7 INDUSTRIAL WORKSTATION IPC847D, CORE I5, ES/OS SINGLESTATION, 500 GB HD SATA, 8GB DDR3, BCE, PCS 7 V9.0, WINDOWS 10 ENTERPRISE 2015 LTSP 64BIT	
1		6ES7658-5AX58-0YA5	SOFTWARE SIMATIC PCS 7 AS/OS ENGINEERING V9.0	
1		6ES7658-7DX58-0YB5	SOFTWARE SIMATIC ROUTE CONTROL ENGINEERING V9.0	
	1	6ES7658-1CX58-2YA5	SOFTWARE SIMATIC PCS 7 VERSION CROSS MANAGER V9.0	
	1	6ES7658-1FX58-2YA5	SOFTWARE SIMATIC PCS 7 VERSION TRAIL V9.0	
	1	6ES7658-1DX58-2YB5	SOFTWARE SIMATIC PCS 7 IMPORT EXPORT ASSISTANT V9.0	

Required	Optional	Article number	Product description	Note
OS server, Route Control server				
1		6ES7660-6EC10-3EA0	SIMATIC PCS 7 INDUSTRIAL WORKSTATION IPC847D, CORE I5, OS-SERVER, RAID1 (2 X 1 TB HDD SATA, DATA MIRRORING), 8GB DDR3, BCE, PCS 7 V9.0, WIN SERVER 2012 R2 STANDARD EDITION INCL. 5 CLIENT 64BIT	
1		6ES7658-2BA58-0YA0	SOFTWARE SIMATIC PCS 7 OS-SERVER V9.0 (PO 100)	1)
1		6ES7658-7FX58-0YB0	SOFTWARE SIMATIC ROUTE CONTROL SERVER V9.0	
1		6ES7658-7FF00-0XB0	SOFTWARE SIMATIC ROUTE CONTROL (10 ROUTES)	3)
OS client, Route Control client				
3		6ES7660-5FA08-3BA0	SIMATIC PCS 7 INDUSTRIAL WORKSTATION IPC647D, CORE I5, OS-CLIENT, 500 GB HD SATA, 4GB DDR3, PCS 7 V9.0, WINDOWS 10 ENTERPRISE 2015 LTSB 64BIT	
3		6ES7658-2CX58-0YB5	SOFTWARE SIMATIC PCS 7 OS-CLIENT V9.0	
	3	6ES7652-0XD58-2YB5	SOFTWARE SIMATIC PCS 7 SFC VISUALIZATION V9.0	
3		6ES7658-7EX58-0YB5	SOFTWARE SIMATIC ROUTE CONTROL CENTER V9.0	
Automation system				
2		6ES7654-6CN03-3BF0	SIMATIC PCS 7 SINGLE AS, CPU 410-5H, 1X DP-MODULE, 2x PROFINET-IO, SYSTEM EXPANSION CARD 1000 PO, AS RT PO 100, CP443-1IE, UR2 ALU RACK, 1 X UC 120/230V 10A POWER SUPPLY	2)
		24 V DC power supply	Redundant power supply	Chapter 17.2

Note

- 1) The number of POs can be increased later by means of extra volume licenses.
- 2) Please use the PCS 7 AS configurator, since different versions of the PCS 7 AS 410-5H are available; e. g., 24V DC or 110/230V AC.
- 3) At least one SIMATIC Route Control Routes license (for sets of 10/50) is required per project. The number of routes can be increased at a later stage with cumulative SIMATIC Route Control Routes Licenses.

8.3 Redundant SIMATIC Route control client / server architecture

In this example configuration, the system has one redundant Route Control server pair and two Route Control clients. The ES is configured on a separate PC. The terminal bus and the plant bus are also set up on a redundant basis.

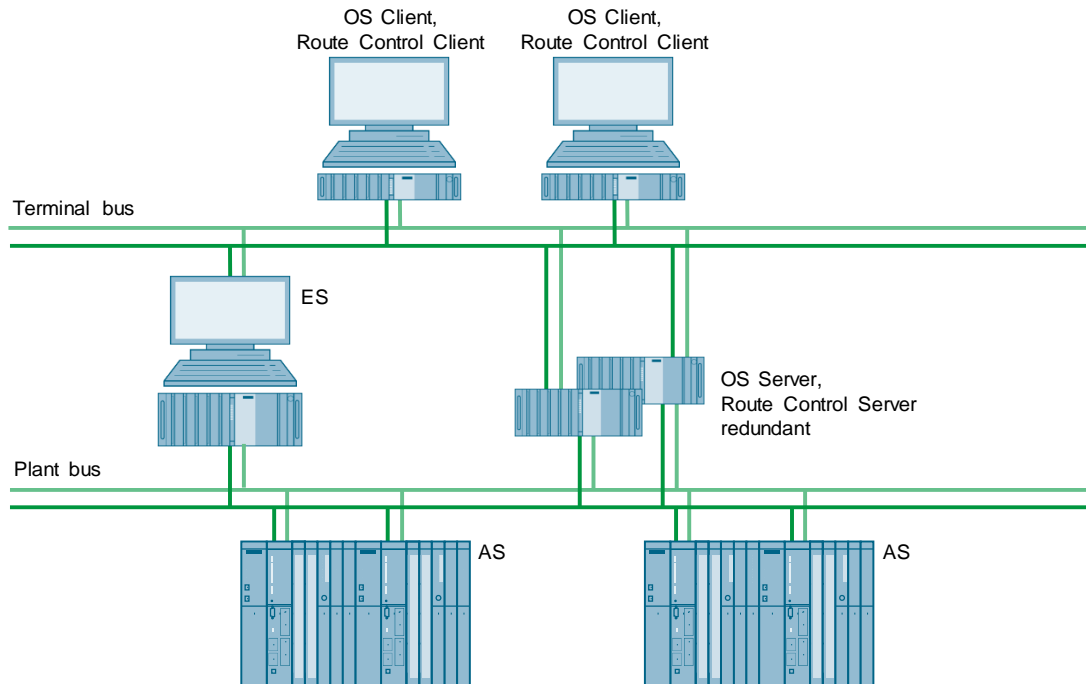

© Siemens AG 2019. All rights reserved.

Bill of materials

Required	Optional	Article number	Product description	Note
Engineering Station				
1		6ES7660-6DF11-3BA0	SIMATIC PCS 7 INDUSTRIAL WORKSTATION IPC847D, CORE I5, ES/OS SINGLESTATION, RAID1 (2 X 1 TB HDD SATA, DATA MIRRORING), 8GB DDR3, INDUSTRIAL ETHERNET (CP1623), PCS 7 V9.0, WINDOWS 10 ENTERPRISE 2015 LT5B 64BIT	
1		6ES7658-5AX58-0YA5	SOFTWARE SIMATIC PCS 7 AS/OS ENGINEERING V9.0	
1		6GK1162-3AA00	SIMATIC NET COMMUNICATION PROCESSOR CP 1623 PCI EXPRESS	1)
1		6GK1716-0HB14-0AC0	SIMATIC NET, S7-REDCONNECT POWERPACK V14	3)
1		6GK1711-1EW14-0AA0	SIMATIC NET SOFTNET-IE RNA V14 REDUNDANT NETWORK ACCESS	7) 8) 9)

8 SIMATIC Route Control

Required	Optional	Article number	Product description	Note
1		6ES7658-7DX58-0YB5	SOFTWARE SIMATIC ROUTE CONTROL ENGINEERING V9.0	
	1	6ES7658-1CX58-2YA5	SOFTWARE SIMATIC PCS 7 VERSION CROSS MANAGER V9.0	
	1	6ES7658-1FX58-2YA5	SOFTWARE SIMATIC PCS 7 VERSION TRAIL V9.0	
	1	6ES7658-1DX58-2YB5	SOFTWARE SIMATIC PCS 7 IMPORT EXPORT ASSISTANT V9.0	
OS server, Route Control server				
2		6ES7660-6EF21-3EA0	SIMATIC PCS 7 INDUSTRIAL WORKSTATION IPC847D, CORE I5, OS-SERVER, RAID1 (2 X 1 TB HDD SATA, DATA MIRRORING), 16GB DDR3, INDUSTRIAL ETHERNET (CP1623), PCS 7 V9.0, WINDOWS SERVER 2012 R2 STANDARD EDITION, 64 BIT	
1		6ES7652-3BA58-2YA0	SOFTWARE SIMATIC PCS 7 OS-SERVER REDUNDANCY V9.0 (PO 100)	2)
2		6GK1162-3AA00	SIMATIC NET COMMUNICATION PROCESSOR CP 1623 PCI EXPRESS	1)
2		6GK1711-1EW14-0AA0	SIMATIC NET SOFTNET-IE RNA V14 REDUNDANT NETWORK ACCES	7) 8) 9)
2		6GK1716-0HB14-0AC0	SIMATIC NET, S7-REDCONNECT POWERPACK V14	3)
2		A5E02639550	DESKTOP ADAPTER NETWORK CARD	6)
1		6XV1870-3RH60	SIMATIC NET INDUSTRIAL ETHERNET TP XP CORD RJ45/RJ45, 6M	
2		6ES7658-7FX58-0YB0	SOFTWARE SIMATIC ROUTE CONTROL SERVER V9.0	
1		6ES7658-7FF00-0XB0	SOFTWARE SIMATIC ROUTE CONTROL (10 ROUTES)	5)
OS client, Route Control client				
2		6ES7660-5FA08-3BA0	SIMATIC PCS 7 INDUSTRIAL WORKSTATION IPC647D, CORE I5, OS-CLIENT, 500 GB HD SATA, 4GB DDR3, PCS 7 V9.0, WINDOWS 10 ENTERPRISE 2015 LTSB 64 Bit	
2		6GK1711-1EW14-0AA0	SIMATIC NET SOFTNET-IE RNA V14 REDUNDANT NETWORK ACCESS	7) 8) 9)
2		6ES7658-2CX58-0YB5	SOFTWARE SIMATIC PCS 7 OS-CLIENT V9.0	
	2	6ES7652-0XD58-2YB5	SOFTWARE SIMATIC PCS 7 SFC VISUALIZATION V9.0	
2		6ES7658-7EX58-0YB5	SOFTWARE SIMATIC ROUTE CONTROL CENTER V9.0	

Required	Optional	Article number	Product description	Note
Automation system				
2		6ES7656-6CN33-1CF0	SIMATIC PCS 7 REDUNDANCY AS, 2X CPU 410-5H, 2 DP-MODULES, 2X PROFINET-IO, SYSTEM EXPANSION CARD 1000 PO, AS RT PO 100, 2 X 2 10M SYNC-MODULES AND 2 X 1M FO, 2 X CP443-1	⁴⁾
		24 V DC power supply	Redundant power supply	Chapter 17.2

Note

- ¹⁾ Needed if a redundant system bus is chosen.
- ²⁾ The number of POs can be increased later by means of extra volume licenses.
- ³⁾ Necessary if a redundant system bus or a redundant automation system is chosen.
- ⁴⁾ Please use the PCS 7 AS configurator, since different versions of the PCS 7 AS 410-5H are available; e. g., 24V DC or 110/230V AC.
- ⁵⁾ At least one SIMATIC Route Control Routes license (for sets of 10/50) is required per project. The number of routes can be increased at a later stage with cumulative SIMATIC Route Control Routes Licenses.
- ⁶⁾ Additional network cards are required for redundancy switching.
- ⁷⁾ The onboard interfaces can be used.
- ⁸⁾ Single license for one installation.
- ⁹⁾ Necessary if a redundant terminal bus is selected.

8.4 SIMATIC Route Control client / server architecture redundant (OS + RCS server separated)

In this example configuration, the system has one redundant route control server pair and two redundant OS server pairs. The five Route Control clients are combined with the five OS clients. The ES is configured on a separate PC.

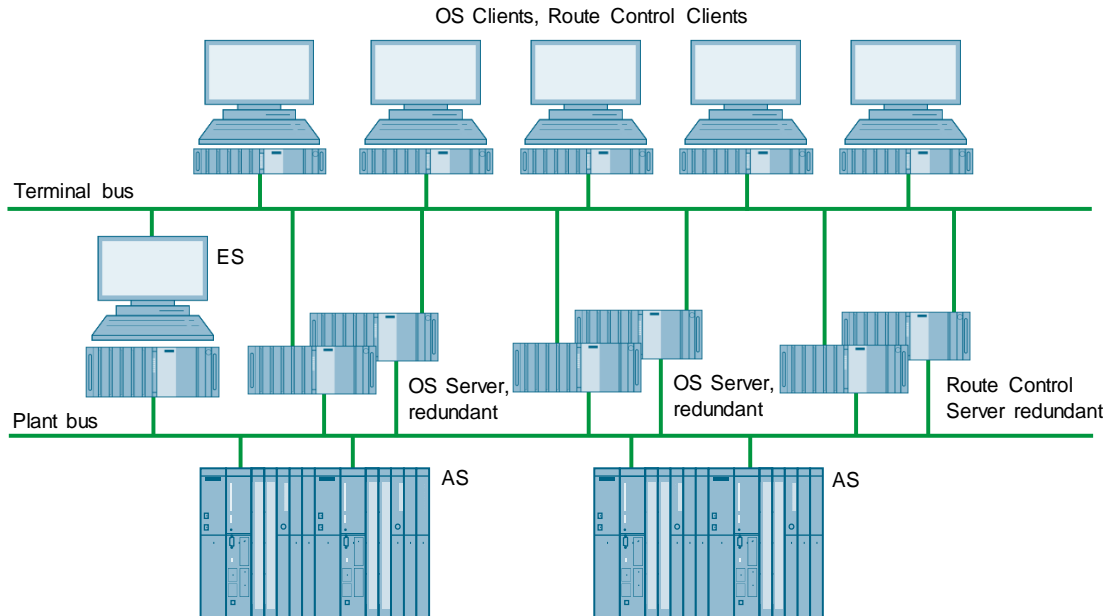

Bill of materials

Required	Optional	Article number	Product description	Note
Engineering Station				
1		6ES7660-6DF21-3BA0	SIMATIC PCS 7 INDUSTRIAL WORKSTATION IPC847D, CORE I5, ES/OS SINGLESTATION, RAID1 (2 X 1 TB HDD SATA, DATA MIRRORING), 16GB DDR3, INDUSTRIAL ETHERNET (CP1623), PCS 7 V9.0, WINDOWS 10 ENTERPRISE 2015 LTSP 64BIT	
1		6ES7658-5AX58-0YA5	SOFTWARE SIMATIC PCS 7 AS/OS ENGINEERING V9.0	
1		6ES7658-7DX58-0YB5	SOFTWARE SIMATIC ROUTE CONTROL ENGINEERING V9.0	
1		6ES7658-1CX58-2YA5	SOFTWARE SIMATIC PCS 7 VERSION CROSS MANAGER V9.0	
1		6ES7658-1FX58-2YA5	SOFTWARE SIMATIC PCS 7 VERSION TRAIL V9.0	
1		6ES7658-1DX58-2YB5	SOFTWARE SIMATIC PCS 7 IMPORT EXPORT ASSISTANT V9.0	
OS server				
4		6ES7660-6EF21-3EA0	SIMATIC PCS 7 INDUSTRIAL WORKSTATION IPC847D, CORE I5, OS-SERVER, RAID1 (2 X 1 TB HDD SATA, DATA MIRRORING), 16GB DDR3, INDUSTRIAL ETHERNET (CP1623), PCS 7 V9.0, WINDOWS SERVER 2012 R2 STANDARD EDITION, 64 BIT	
4		6GK1716-0HB14-0AC0	SIMATIC NET, S7-REDCONNECT POWERPACK V14	1)
2		6ES7652-3BA58-2YA0	SOFTWARE SIMATIC PCS 7 OS-SERVER REDUNDANCY V9.0 (PO 100)	2) 6)
Route Control server				
2		6ES7660-6EF21-3EA0	SIMATIC PCS 7 INDUSTRIAL WORKSTATION IPC847D, CORE I5, OS-SERVER, RAID1 (2 X 1 TB HDD SATA, DATA MIRRORING), 16GB DDR3, INDUSTRIAL ETHERNET (CP1623), PCS 7 V9.0, WINDOWS SERVER 2012 R2 STANDARD EDITION, 64 BIT	
2		A5E02639550	DESKTOP ADAPTER NETWORK CARD	5)
1		6XV1870-3RH60	SIMATIC NET INDUSTRIAL ETHERNET TP XP CORD RJ45/RJ45, 6M	
2		6GK1716-0HB14-0AC0	SIMATIC NET, S7-REDCONNECT POWERPACK V14	1)
2		6ES7658-7FX58-0YB0	SOFTWARE SIMATIC ROUTE CONTROL SERVER V9.0	
1		6ES7658-7FF00-0XB0	SOFTWARE SIMATIC ROUTE CONTROL (10 ROUTES)	4)

Required	Optional	Article number	Product description	Note
OS client, Route Control client				
5		6ES7660-5FA08-3BA0	SIMATIC PCS 7 INDUSTRIAL WORKSTATION IPC647D, CORE I5, OS-CLIENT, 500 GB HD SATA, 4GB DDR3, PCS 7 V9.0, WINDOWS 10 ENTERPRISE 2015 LTSB 64BIT	
5		6ES7658-2CX58-0YB5	SOFTWARE SIMATIC PCS 7 OS-CLIENT V9.0	
	5	6ES7652-0XD58-2YB5	SOFTWARE SIMATIC PCS 7 SFC VISUALIZATION V9.0	
5		6ES7658-7EX58-0YB5	SOFTWARE SIMATIC ROUTE CONTROL CENTER V9.0	
Automation system				
2		6ES7656-6CQ33-1CF0	SIMATIC PCS 7 REDUNDANCY AS, 2X CPU 410-5H, 2 DP-MODULE, 2X PROFINET-IO, SYSTEM EXPANSION CARD 2k+ PO, AS RT PO 100, 2 X 2 10M SYNC-MODULE AND 2 X 1M FO, 2 X CP443-1 IE/PN, 1 X UR2-H ALU RACK, 2 X UC 120/230V 10A RED. POWER SUPPLY	³⁾
		24 V DC power supply	Redundant power supply	Chapter 17.2

Note

- 1) Required for redundant automation system.
- 2) The number of POs can be increased later by means of extra volume licenses.
- 3) Please use the PCS 7 AS configurator, since different versions of the PCS 7 AS 410-5H are available; e. g., 24V DC or 110/230V AC.
- 4) At least one SIMATIC Route Control Routes license (for sets of 10/50) is required per project. The number of routes can be increased at a later stage with cumulative SIMATIC Route Control Routes Licenses.
- 5) Additional network cards are required for redundancy switching.
- 6) The redundant OS server pair is supplied with an RS-232 serial connection cable. If there is a long distance between the redundant systems, you can use an Ethernet connection instead. This requires additional Ethernet network interface cards in the systems.

9 SIMATIC Route Control and SIMATIC BATCH

For BATCH applications that need transparent material transportation between sub-systems, SIMATIC PCS 7 supports the integration of SIMATIC BATCH and SIMATIC Route Control into a single system. The ISA-88-based recipe management and batch processing software SIMATIC BATCH integrates seamlessly with Route Control and allows material transport to be controlled via the recipe functions in the control recipe. Both SIMATIC BATCH and Route Control can be used for systems that range from starter size up to distributed client/server architectures.

Using SIMATIC BATCH and SIMATIC Route Control in a single system, it is possible to implement the following configurations:

Single user system

The smallest system is the single user architecture. All software packages (server / client / engineering) of OS, SIMATIC BATCH and Route Control are installed on a single computer.

Client / server architecture

Mid-sized systems that support multiple users and do not need redundancy are implemented as client / server systems. SIMATIC BATCH and SIMATIC Route Control use the OS architecture by utilizing the BATCH and Route Control server / client applications on the corresponding OS PCs.

Client / server architecture redundant (OS + SB+RCS combined)

When redundancy is required and the number of servers must be kept as small as possible, SIMATIC BATCH and SIMATIC Route Control can be used on the basis of redundant OS servers (a combination of three redundant functions on two servers).

Client / server architecture redundant (OS + SB and RCS separated)

When it comes to large, high-performance applications, the SIMATIC PCS 7 client / server architecture allows the distribution of applications across multiple PCs. In this case, the BATCH server, Route Control server and OS server run on independent PCs. Each of them can be configured redundantly, as a result of which high level of availability is achieved. The OS client PCs can be installed together with the BATCH and Route Control client applications and can therefore access the OS server as well as the BATCH and Route Control server. If necessary, the OS client, Route Control client and BATCH client application can run on separate PCs as well.

The illustration below shows a sample configuration with three OS clients / Route Control clients / BATCH clients.
The OS Server, Route Control server, and the BATCH server are integrated on one PC. This ES is a separate PC.

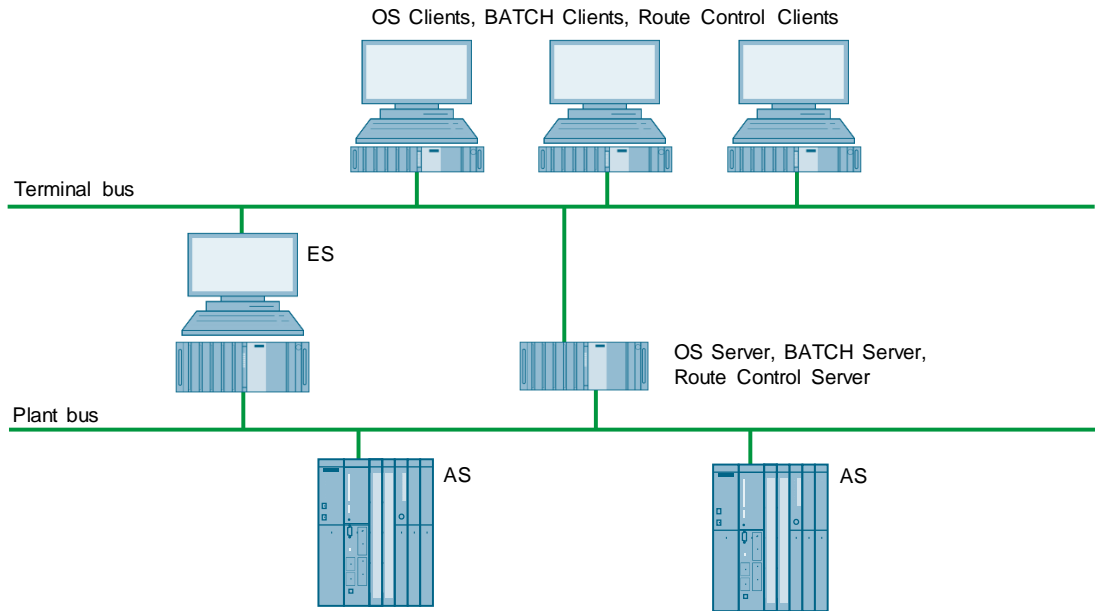

10 Archiving

SIMATIC PCS 7 digital preservation

Archiving of data for analysis purposes where the system collects large amounts of data over long periods is supported by the Process Historian. The Process Historian collects the archive data from the OS servers or OS single stations. Batch data can also be archived on the Process Historian. These archive data can be visualized directly on OS clients or single stations.

The information server can be used to display these data in reports. For long-term archiving, archive data from the Process Historian can be stored on external media (backup drives). If the stored data are required at a later point in time for the purpose of the analysis, these can be restored on the Process Historian.

Client / server system

The Process Historian always runs on a separate PC. The choice of hardware depends on the plant configuration and archiving load of the Process Historian. The PH-HWAdvisor software tool can be used to determine the correct Process Historian hardware for a given PCS 7 quantity structure.

Note The PH-HWAdvisor can be downloaded free of charge in the article "Determination of suitable hardware for the Process Historian 2014 with the "PH-HWAdvisor" tool":
<https://support.industry.siemens.com/cs/ww/en/view/109740115>

Note For PCS 7 quantity structures with one OS server, up to four OS clients, an archive load of up to 1500 variable(s) and 10 alarms/min, an IPC 847 D can be used as the hardware basis for a Process Historian.

The operation of a combined Process Historian / Information Server on an IPC 847 D is not recommended.

For more information on hardware requirements can be found in the manual "Process Historian 2014 SP2" in the chapter "Process Historian - Installation Notes":
<https://support.industry.siemens.com/cs/ww/en/view/109748863>

All OS clients can retrieve data from the Process Historian. From the perspective of the OS client, there is no difference between access to data of the OS server or data of the Process Historian.

Redundant OS server, single Process Historian

If redundant operation and monitoring are required and a high availability of archive data is not mandatory, a single Process Historian can be connected to a redundant OS server pair.

Redundant Process Historian

If high availability of archive data is needed, SIMATIC PCS 7 offers the option of a redundant Process Historian.

Information Server

The Information Server is the reporting system of the Process Historian. Based on the Microsoft Reporting Services, it offers web-based thin-client access to the historical data. Add-ins for Microsoft Word and Excel provide additional access to the database of the Process Historian. The Information Server can be installed and operated on the Process Historian hardware or on separate hardware. When the Process Historian is configured redundantly, the separation of the Information Server is mandatory. An OS client version of the SIMATIC PCS 7 Industrial Workstation is suitable for the separate Information Server.

Note

When selecting the information server computer hardware, please note the hardware requirements in the manual "Information Server 2014 SP2" in the chapter "Information Server - Installation Notes":
<https://support.industry.siemens.com/cs/ww/en/view/109748956>

10.1 OS client / OS server

In this configuration, the system has one OS server and two OS clients. The ES and Process Historian / Information Server are each configured on a separate PC.

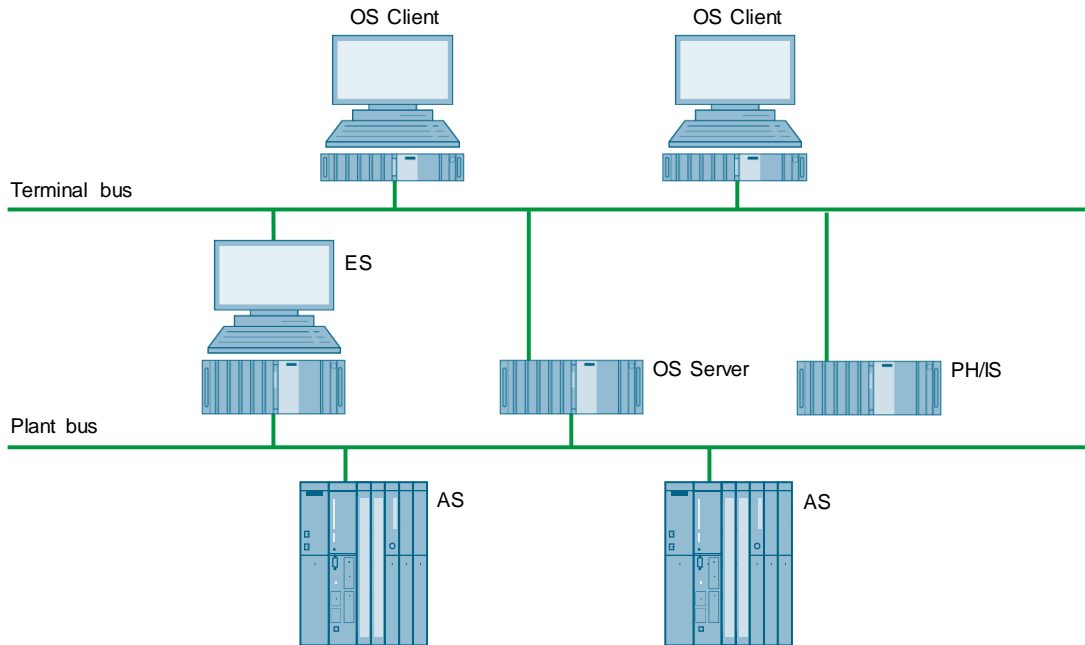

Bill of materials

Required	Optional	Article number	Product description	Note
Engineering Station				
1		6ES7660-6DA10-3BA0	SIMATIC PCS 7 INDUSTRIAL WORKSTATION IPC847D, CORE I5, ES/OS SINGLESTATION, 500 GB HD SATA, 8GB DDR3, BCE, PCS 7 V9.0, WINDOWS 10 ENTERPRISE 2015 LTSB 64BIT	
1		6ES7658-5AX58-0YA5	SOFTWARE SIMATIC PCS 7 AS/OS ENGINEERING V9.0	
	1	6ES7658-1CX58-2YA5	SOFTWARE SIMATIC PCS 7 VERSION CROSS MANAGER V9.0	
	1	6ES7658-1FX58-2YA5	SOFTWARE SIMATIC PCS 7 VERSION TRAIL V9.0	
	1	6ES7658-1DX58-2YB5	SOFTWARE SIMATIC PCS 7 IMPORT EXPORT ASSISTANT V9.0	

Required	Optional	Article number	Product description	Note
OS server				
1		6ES7660-6EC10-3EA0	SIMATIC PCS 7 INDUSTRIAL WORKSTATION IPC847D, CORE I5, OS-SERVER, RAID1 (2 X 1 TB HDD SATA, DATA MIRRORING), 8GB DDR3, BCE, PCS 7 V9.0, WIN SERVER 2012 R2 STANDARD EDITION INCL. 5 CLIENT 64BIT	
1		6ES7658-2BA58-0YA0	SOFTWARE SIMATIC PCS 7 OS-SERVER V9.0 (PO 100)	1) 3)
Process Historian / Information Server				
1			DETERMINATION OF THE HARDWARE USING THE PH-HWAdvisor.	
1		6ES7652-7AX58-2YB0	SOFTWARE SIMATIC PCS 7 PROCESS HISTORIAN AND INFORMATION SERVER BASIC PACKAGE V9.0	
1		6ES7652-7YA00-2YB0	SOFTWARE SIMATIC PCS 7 INFORMATION SERVER CLIENT ACCESS (1 CLIENT)	4)
OS client				
2		6ES7660-5FA08-3BA0	SIMATIC PCS 7 INDUSTRIAL WORKSTATION IPC647D, CORE I5, OS-CLIENT, 500 GB HD SATA, 4GB DDR3, PCS 7 V9.0, WINDOWS 10 ENTERPRISE 2015 LTSB 64BIT	
2		6ES7658-2CX58-0YB5	SOFTWARE SIMATIC PCS 7 OS-CLIENT V9.0	
	2	6ES7652-0XD58-2YB5	SOFTWARE SIMATIC PCS 7 SFC VISUALIZATION V9.0	
Automation system				
2		6ES7654-6CN03-3BF0	SIMATIC PCS 7 SINGLE AS, CPU 410-5H, 1X DP-MODULE, 2x PROFINET-IO, SYSTEM EXPANSION CARD 1000 PO, AS RT PO 100, CP443-1IE, UR2 ALU RACK, 1 X UC 120/230V 10A POWER SUPPLY	2)
		24 V DC power supply	Redundant power supply	Chapter 17.2

Note

- 1) The number of POs can be increased later by means of extra volume licenses.
- 2) Please use the PCS 7 AS configurator, since different versions of the PCS 7 AS 410-5H are available; e. g., 24V DC or 110/230V AC.
- 3) The tag inventory can be expanded to up to 120,000 archive tags using cumulative SIMATIC PCS 7 OS/PH Archive volume licenses.
- 4) The number of clients can be expanded with cumulative Information Server client access licenses.

10.2 Redundant OS server pair and single Process Historian

In this configuration, the system has one redundant OS server pair and two OS clients. The ES and Process Historian / Information Server are each configured on a separate PC. The terminal bus and the plant bus are also set up on a redundant basis.

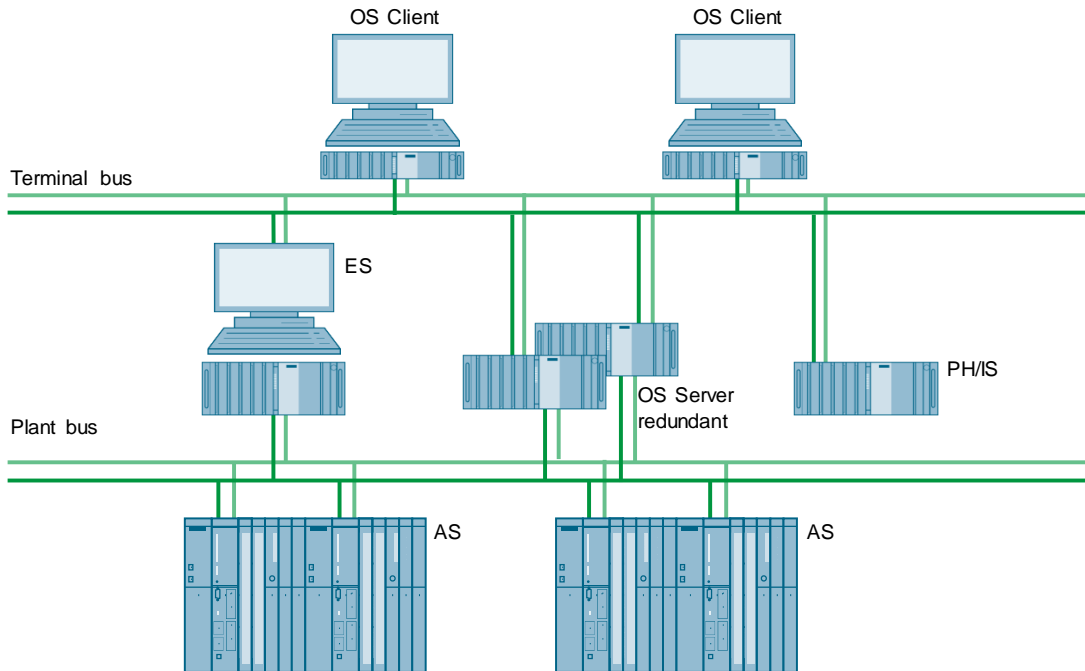

Bill of materials

Required	Optional	Article number	Product description	Note
Engineering system				
1		6ES7660-6DF21-3BA0	SIMATIC PCS 7 INDUSTRIAL WORKSTATION IPC847D, CORE I5, ES/OS SINGLESTATION, RAID1 (2 X 1 TB HDD SATA, DATA MIRRORING), 16GB DDR3, INDUSTRIAL ETHERNET (CP1623), PCS 7 V9.0, WINDOWS 10 ENTERPRISE 2015 LTSP 64BIT	
1		6ES7658-5AX58-0YA5	SOFTWARE SIMATIC PCS 7 AS/OS ENGINEERING V9.0	
1		6GK1162-3AA00	SIMATIC NET COMMUNICATION PROCESSOR CP 1623 PCI EXPRESS	1)
1		6GK1716-0HB14-0AC0	SIMATIC NET, S7-REDCONNECT POWERPACK V14	3)
1		6GK1711-1EW14-0AA0	SIMATIC NET SOFTNET-IE RNA V14 REDUNDANT NETWORK ACCESS	8) 9) 10)

Required	Optional	Article number	Product description	Note
	1	6ES7658-1CX58-2YA5	SOFTWARE SIMATIC PCS 7 VERSION CROSS MANAGER V9.0	
	1	6ES7658-1FX58-2YA5	SOFTWARE SIMATIC PCS 7 VERSION TRAIL V9.0	
	1	6ES7658-1DX58-2YB5	SOFTWARE SIMATIC PCS 7 IMPORT EXPORT ASSISTANT V9.0	
OS server				
2		6ES7660-6EF21-3EA0	SIMATIC PCS 7 INDUSTRIAL WORKSTATION IPC847D, CORE I5, OS-SERVER, RAID1 (2 X 1 TB HDD SATA, DATA MIRRORING), 16GB DDR3, INDUSTRIAL ETHERNET (CP1623), PCS 7 V9.0, WINDOWS SERVER 2012 R2 STANDARD EDITION, 64 BIT	
1		6ES7652-3BA58-2YA0	SOFTWARE SIMATIC PCS 7 OS-SERVER REDUNDANCY V9.0 (PO 100)	2) 5)
2		6GK1162-3AA00	SIMATIC NET COMMUNICATION PROCESSOR CP 1623 PCI EXPRESS	1)
2		6GK1716-0HB14-0AC0	SIMATIC NET, S7-REDCONNECT POWERPACK V14	3)
2		6GK1711-1EW14-0AA0	SIMATIC NET SOFTNET-IE RNA V14 REDUNDANT NETWORK ACCESS	8) 9) 10)
Process Historian / Information Server				
1			DETERMINATION OF THE HARDWARE USING THE PH-HWAdvisor.	11)
1		6GK1711-1EW14-0AA0	SIMATIC NET SOFTNET-IE RNA V14 REDUNDANT NETWORK ACCESS	8) 9) 10)
1		6ES7652-7EX58-2YB0	SOFTWARE SIMATIC PCS 7 PROCESS HISTORIAN AND INFORMATION SERVER BASIC PACKAGE V9.0	
1		6ES7652-7AX58-2YB0	SOFTWARE SIMATIC PCS 7 INFORMATION SERVER CLIENT ACCESS 1 CLIENT	7)
OS client				
2		6ES7660-5FA08-3BA0	SIMATIC PCS 7 INDUSTRIAL WORKSTATION IPC647D, CORE I5, OS-CLIENT, 500 GB HD SATA, 4GB DDR3, PCS 7 V9.0, WINDOWS 10 ENTERPRISE 2015 LTSC 64 Bit	
2		6GK1711-1EW14-0AA0	SIMATIC NET SOFTNET-IE RNA V14 REDUNDANT NETWORK ACCESS	8) 9) 10)
2		6AV6881-0AU14-0AA0	USB KEYBOARD TKL-105 GERMAN	
2		6ES7658-2CX58-0YB5	SOFTWARE SIMATIC PCS 7 OS-CLIENT V9.0	
	2	6ES7652-0XD58-2YB5	SOFTWARE SIMATIC PCS 7 SFC VISUALIZATION V9.0	

Required	Optional	Article number	Product description	Note
Automation system				
2		6ES7656-6CN33-1CF0	SIMATIC PCS 7 REDUNDANCY AS, 2X CPU 410-5H, 2 DP-MODULES, 2X PROFINET-IO, SYSTEM EXPANSION CARD 1000 PO, AS RT PO 100, 2 X 2 10M SYNC-MODULES AND 2 X 1M FO, 2 X CP443-1	⁴⁾
		24 V DC power supply	Redundant power supply	Chapter 17.2

Note

- ¹⁾ Needed if a redundant system bus is chosen.
- ²⁾ The number of POs can be increased later by means of extra volume licenses.
- ³⁾ Necessary if a redundant system bus or a redundant automation system is chosen.
- ⁴⁾ Please use the PCS 7 AS configurator, since different versions of the PCS 7 AS 410-5H are available; e. g., 24V DC or 110/230V AC.
- ⁵⁾ The tag inventory can be expanded to up to 120,000 archive tags using cumulative SIMATIC PCS 7 OS Archive volume licenses.
- ⁶⁾ The redundant OS server pair is supplied with an RS-232 serial connection cable. If there is a long distance between the redundant systems, you can use an Ethernet connection instead. This requires additional Ethernet network interface cards in the systems.
- ⁷⁾ The number of clients can be expanded with cumulative Information Server Client Access licenses.
- ⁸⁾ The onboard interfaces can be used.
- ⁹⁾ Single license for one installation.
- ¹⁰⁾ Necessary if a redundant terminal bus is selected.
- ¹¹⁾ This configuration requires hardware with two network cards.

10.3 Redundant OS server pair and redundant Process Historian

In this configuration, the system has one redundant OS server pair and two OS clients. The ES, information server and Process Historian are each configured on a separate PC, with the Process Historian being configured on a redundant basis. The terminal bus and the plant bus are also set on a redundant basis.

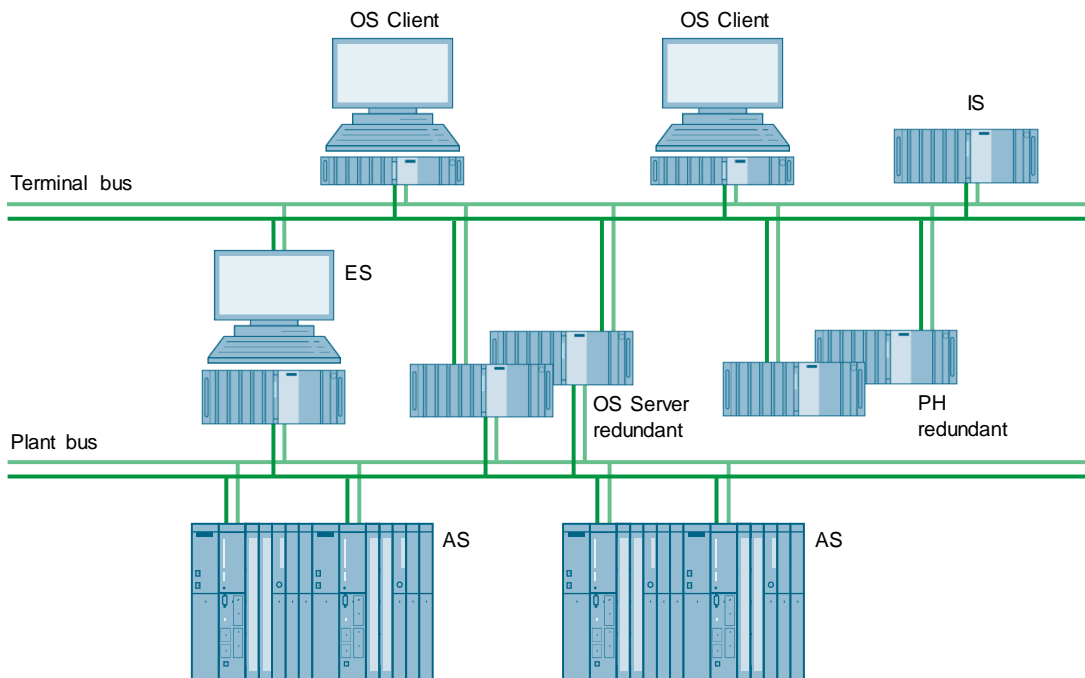

© Siemens AG 2019. All rights reserved

Bill of materials

Required	Optional	Article number	Product description	Note
Engineering Station				
1		6ES7660-6DF11-3BA0	SIMATIC PCS 7 INDUSTRIAL WORKSTATION IPC847D, CORE I5, ES/OS SINGLESTATION, RAID1 (2 X 1 TB HDD SATA, DATA MIRRORING), 8GB DDR3, INDUSTRIAL ETHERNET (CP1623), PCS 7 V9.0, WINDOWS 10 ENTERPRISE 2015 LTSB 64BIT	
1		6ES7658-5AX58-0YA5	SOFTWARE SIMATIC PCS 7 AS/OS ENGINEERING V9.0	
1		6GK1162-3AA00	SIMATIC NET COMMUNICATION PROCESSOR CP 1623 PCI EXPRESS	1)
1		6GK1716-0HB14-0AC0	SIMATIC NET, S7-REDCONNECT POWERPACK V14	3)
1		6GK1711-1EW14-0AA0	SIMATIC NET SOFTNET-IE RNA V14 REDUNDANT NETWORK ACCESS	9)
	1	6ES7658-1CX58-2YA5	SOFTWARE SIMATIC PCS 7 VERSION CROSS MANAGER V9.0	
	1	6ES7658-1FX58-2YA5	SOFTWARE SIMATIC PCS 7 VERSION TRAIL V9.0	

Required	Optional	Article number	Product description	Note
	1	6ES7658-1DX58-2YB5	SOFTWARE SIMATIC PCS 7 IMPORT EXPORT ASSISTANT V9.0	
OS server				
2		6ES7660-6EF21-3EA0	SIMATIC PCS 7 INDUSTRIAL WORKSTATION IPC847D, CORE I5, OS-SERVER, RAID1 (2 X 1 TB HDD SATA, DATA MIRRORING), 16GB DDR3, INDUSTRIAL ETHERNET (CP1623), PCS 7 V9.0, WINDOWS SERVER 2012 R2 STANDARD EDITION, 64 BIT	
1		6ES7652-3BA58-2YA0	SOFTWARE SIMATIC PCS 7 OS-SERVER REDUNDANCY V9.0 (PO 100)	2) 5)
2		6GK1162-3AA00	SIMATIC NET COMMUNICATION PROCESSOR CP 1623 PCI EXPRESS	1)
2		6GK1711-1EW14-0AA0	SIMATIC NET SOFTNET-IE RNA V14 REDUNDANT NETWORK ACCESS	9)
2		6GK1716-0HB14-0AC0	SIMATIC NET, S7-REDCONNECT POWERPACK V14	3)
Process Historian				
2			DETERMINATION OF THE HARDWARE USING THE PH-HWAdvisor.	8) 10)
1		6ES7652-7CX58-2YB0	SOFTWARE SIMATIC PCS 7 PROCESS HISTORIAN SERVER REDUNDANCY V9.0	
2		6GK1711-1EW14-0AA0	SIMATIC NET SOFTNET-IE RNA V14 REDUNDANT NETWORK ACCESS	9)
Information Server				
1		6ES7660-6HN38-3EA0	SIMATIC PCS 7 INDUSTRIAL WORKSTATION IPC847D, XEON E3, OS SERVER, RAID1 (2 x 1 TB HDD SATA, DATA MIRRORING) + 240GB SSD SATA, 32GB DDR3, PCS 7 V9.0, OPERATING SYSTEM WINDOWS SERVER 2012 R2 STANDARD EDITION, 64 Bit incl. 5 CAL	
1		6GK1711-1EW14-0AA0	SIMATIC NET SOFTNET-IE RNA V14 REDUNDANT NETWORK ACCESS	9)
1		6ES7652-7EX58-2YB0	SOFTWARE SIMATIC PCS 7 INFORMATION SERVER BASIC PACKAGE V9.0	
1		6ES7652-7YA00-2YB0	SOFTWARE SIMATIC PCS 7 INFORMATION SERVER CLIENT ACCESS 1 CLIENT	7)

Required	Optional	Article number	Product description	Note
OS client				
2		6ES7660-5FA08-3BA0	SIMATIC PCS 7 INDUSTRIAL WORKSTATION IPC647D, CORE I5, OS-CLIENT, 500 GB HD SATA, 4GB DDR3, PCS 7 V9.0, WINDOWS 10 ENTERPRISE 2015 LTSB 64 Bit	
2		6GK1711-1EW14-0AA0	SIMATIC NET SOFTNET-IE RNA V14 REDUNDANT NETWORK ACCESS	⁹⁾
2		6ES7658-2CX58-0YB5	SOFTWARE SIMATIC PCS 7 OS-CLIENT V9.0	
	2	6ES7652-0XD58-2YB5	SOFTWARE SIMATIC PCS 7 SFC VISUALIZATION V9.0	
Automation system				
2		6ES7656-6CN33-1CF0	SIMATIC PCS 7 REDUNDANCY AS, 2X CPU 410-5H, 2 DP-MODULES, 2X PROFINET-IO, SYSTEM EXPANSION CARD 1000 PO, AS RT PO 100, 2 X 2 10M SYNC-MODULES AND 2 X 1M FO, 2 X CP443-1	⁴⁾
		24 V DC power supply	Redundant power supply	Chapter 17.2

Note

- ¹⁾ Needed if a redundant system bus is chosen.
- ²⁾ The number of POs can be increased later by means of extra volume licenses.
- ³⁾ Necessary if a redundant system bus or a redundant automation system is chosen.
- ⁴⁾ Please use the PCS 7 AS configurator, since different versions of the PCS 7 AS 410-5H are available; e. g., 24V DC or 110/230V AC.
- ⁵⁾ The tag inventory can be expanded to up to 120,000 archive tags using cumulative SIMATIC PCS 7 OS Archive volume licenses.
- ⁶⁾ The redundant OS server pair is supplied with an RS-232 serial connection cable. If there is a long distance between the redundant systems, you can use an Ethernet connection instead. This requires additional Ethernet network interface cards in the systems.
- ⁷⁾ The number of clients can be expanded with cumulative Information Server Client Access licenses.
- ⁸⁾ Third network card used for redundancy comparison.
- ⁹⁾ The onboard interfaces can be used. Single License for one installation. Necessary if a redundant terminal bus is selected.
- ¹⁰⁾ This configuration requires hardware with two network cards.

11 Fieldbus

PROFESSIONAL DP/PROFESSIONAL PA/FOUNDATION Fieldbus/PROFESSIONAL Fieldbus

SIMATIC PCS 7 enables the connection of different fieldbus technologies through flexible architectures and seamless integration. In this connection, the process devices can be connected to the automation system either via PROFINET or PROFIBUS DP.

PROFINET is based on the international standards IEC 61158 and IEC 61784 and combines the advantages of the open network standard, Ethernet and PROFIBUS fieldbus system.

With PROFINET, a large number of devices at the field level can communicate at a speed of up to 100 Mbps. Within a network, the number of devices is almost unlimited. Up to 250 devices can be connected per PROFINET interface of the automation system. Directly connected PROFINET devices, such as decentralized peripherals and drives, as well as PROFIBUS DP compact devices and PROFIBUS PA process devices integrated via the IE/PB-Link PN IO are supported as devices.

PROFINET offers countless possibilities for networking these devices in the system with line, ring, tree and star topologies. In order to reduce the planning effort and eliminate possible sources of error, PROFINET Blueprints provide tested, scalable network configurations. These are tailored to typical system configurations of process automation and are recommended as prepared solution approaches or standard blocks for planning PROFINET networks.

Note

The PROFINET Blueprints and further information on the integration of PROFINET in SIMATIC PCS 7 can be found in the application example "PROFINET in Process Automation with SIMATIC PCS 7":
<https://support.industry.siemens.com/cs/ww/en/view/72887082>

The PROFIBUS DP, based on the robust RS-485 technology, is a proven fieldbus that supports reliable data exchange with up to 125 slaves per network. SIMATIC PCS 7 automation systems are equipped with the PROFIBUS DP master functionality and can be extended to several PROFIBUS DP networks.

Repeaters increase expansion of the PROFIBUS network across multiple isolated segments and also the number of possible devices to a maximum of 125 slaves. If diagnostics functions for physical cable diagnostics are desired in addition to the standard repeater functionality, a diagnostics repeater can be used as an alternative. It monitors the copper bus cables in online mode. In the event of a fault, it sends a diagnostic message with detailed information about the type and location of the fault to the PROFIBUS DP master.

Intelligent field devices based on the PROFIBUS PA and FOUNDATION Fieldbus H1 standards can be integrated in SIMATIC PCS 7 by connecting them directly to the PROFIBUS DP via dedicated gateways (e. g. PA Link and Compact FF Link). In addition to data transfer, the PROFIBUS PA and FOUNDATION Fieldbus H1 field devices are fed via the bus.

Note

Further information on the integration of FOUNDATION Fieldbus H1 (FF) in SIMATIC PCS 7 can be found in the application example "Configuration of FOUNDATION Fieldbus H1 (FF) with SIMATIC PCS 7":
<https://support.industry.siemens.com/cs/ww/en/view/64329637>

DP/PA couplers, PA Link and Compact FF Link components act as network transitions between the PROFIBUS DP networks and the PA/FF side supplied via bus. This

means that a larger number of PROFIBUS PA slaves and FF field devices can be used without overloading the existing PROFIBUS DP address space.

Intrinsically-safe components for PROFIBUS DP, PROFIBUS PA and FOUNDATION Fieldbus H1 make it possible to use field devices directly in an environment at risk from explosions.

Optical PROFIBUS DP

To implement greater distances and to achieve ring fault tolerance and electrical isolation, PROFIBUS DP allows the use of fiber-optic network components. The optical PROFIBUS DP can be set up as a simple line or fault-tolerant ring. Both design variants are possible for both the individual and redundant PROFIBUS DP fieldbus.

Redundant electrical PROFIBUS DP, PROFIBUS PA and FOUNDATION Fieldbus H1

If a high level of availability is required, PROFIBUS DP supports the setup of redundant networks for the connection of IO Racks, DP/PA and FF Links by using an H-system. A redundant PROFIBUS DP network consists of two separate electrical lines which are connected to the two PROFIBUS masters of the H system and several redundant DP slaves. The PA Link and FF Compact FF Link gateways provide the opportunity to build the field device bus PROFIBUS PA or FOUNDATION Fieldbus H1 as a fault-tolerant ring, thereby increasing the availability of the complete field device network. The redundant PROFIBUS PA is available in combination with individual and redundant PROFIBUS DP networks. The redundant FOUNDATION Fieldbus H1 is available when using the Compact FF Link with redundant PROFIBUS DP.

Electrical and optical PROFINET

PROFINET enables the use of electrical and optical cables as a transmission medium. Optical cables offer, for example, advantages in terms of EMC load and make it possible to bridge longer distances, whereas electrical cables are cheaper and less sensitive to mechanical influences. Both transmission media can be used in combination and are suitable for point-to-point connections as well as for the setup of MRP rings.

Redundancy concepts for the PROFINET Fieldbus

PROFINET provides two redundancy concepts for increasing the availability of PROFINET devices.

This includes setting up ring topologies using the Media Redundancy Protocol (MRP) and connecting the devices to highly available automation systems via system redundancy. Both concepts are independent of each other and can be used separately or combined.

The Media Redundancy Protocol (MRP) is defined in the IEC 62439 standard and allows ring topologies with up to 50 nodes. All nodes must support the media redundancy with MRP.

In functional condition, the redundancy manager (a predefined node of the ring) opens the ring and therefore ensures loop-free communication. If the transmission path in the ring is interrupted at one point, e. g. by disconnecting the ring line or failure of a node, the redundancy manager immediately closes the ring and, as a result, provides an alternative communication path. The maximum reconfiguration time is 200 ms.

When connecting devices to highly available automation systems, a distinction is made between two variants:

- Simple S2 system redundancy: Each device has an interface module that establishes a connection to both controllers of the H system
- Redundant PROFINET configuration (R1) Each device has two interface modules, each of which establishes a connection to a controller of the H system.

The advantage of the redundant PROFINET configuration R1 is that the level of availability of the IO devices is increased through the two interface modules and communication via two separate PROFINET networks (subnetworks).

Note

Further information on the structure of ring topologies with MRP as well as on simple and redundant PROFINET configurations can be found in the application example "PROFINET in Process Automation with SIMATIC PCS 7".
<https://support.industry.siemens.com/cs/ww/en/view/72887082>

11.1 DP-PA / DP-FF Fieldbus

In this configuration, the system has PROFIBUS DP, PROFIBUS PA, and FOUNDATION Fieldbus. When connecting devices to high-availability automation systems, a distinction is made between two variants:

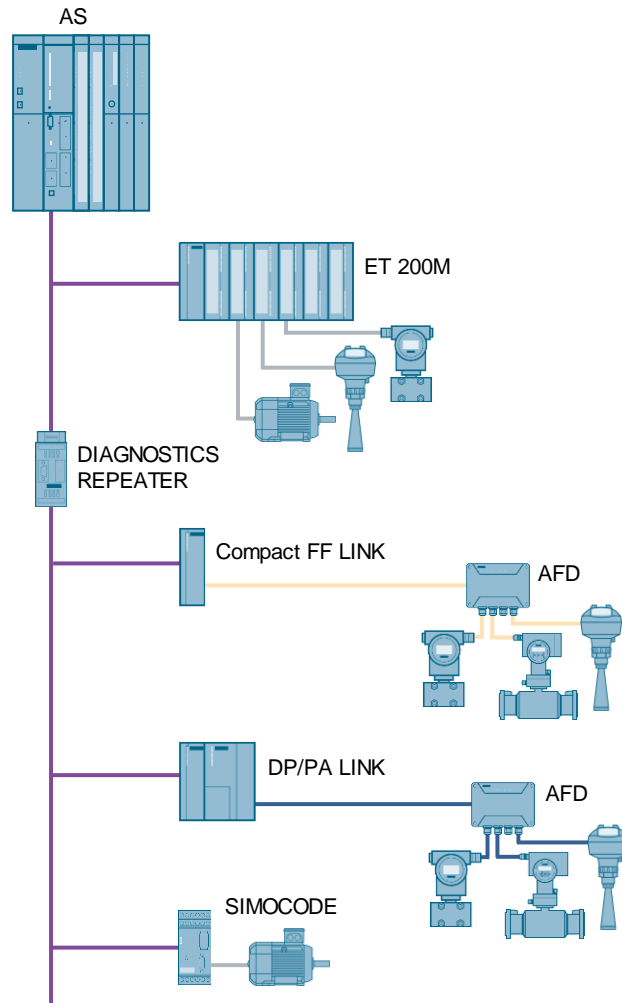

Bill of materials

Required	Optional	Article number	Product description	Note
Automation system				
1		6ES7654-6CL03-3BF0	SIMATIC PCS 7 SINGLE AS, CPU 410-5H, SYSTEM EXPANSIONS CARD 500 PO, AS RT PO 100, CP443-1IE, UR2 ALU RACK, UC 120/230V 10A POWER SUPPLY	1)
		24 V DC power supply	Redundant power supply	Chapter 17.2
ET 200M				
1		6ES7153-2BA10-0XB0	SIMATIC DP, ET 200M INTERFACE IM 153-2 HIGH FEATURE FOR MAX. 12 S7-300 MODULES	2) 3)
1		6ES7195-7HA00-0XA0	SIMATIC DP, BUS UNIT FOR ET200M	
1		6ES7195-7HB00-0XA0	SIMATIC DP, BUS UNIT FOR ET200M F. THE INTEGR.OF TWO 40 MM WIDE I/O SUBMODULES	4)
DIAGNOSTICS REPEATER				
	1	6ES7972-0AA02-0XA0	SIMATIC DP, RS485 DIAGNOSTICS REPEATER	2)
DP/PA LINK				
1		6ES7153-2BA70-0XB0	SIMATIC DP, INTERFACE DP/PA-LINK A. ET200M IM153-2 HF	2) 5)
1		6ES7157-0AC85-0XA0	SIMATIC DP, FIELD DEVICE LINK DP/PA COUPLER FDC 157-0 NON EX-VERSION	6)
1		6ES7195-7HA00-0XA0	SIMATIC DP, BUS UNIT FOR ET200M F. THE INTEGR.OF 1 PS A.1 IM153	
1		6ES7195-7HF80-0XA0	SIMATIC DP, BUS UNIT BM DP/PA FOR EXPANDED TEMPERATURE RANGE SUBMODULE FOR DP/PA COUPLER	
1		6ES7157-0AG81-0XA0	ACT. FIELD DISTRIBUTOR AFD FOR PROFIBUS PA RING	
Compact FF LINK				
1		6ES7658-3MD68-0YA5	SOFTWARE SIMATIC PDM PCS 7-FF V9.1 (100 TAGS)	7)
1		6ES7655-5BA00-0AB0	SIMATIC COMPACT FF LINK COMBINATION OF DP/FF LINK AND FF COUPLER	2) 8)
SIMOCODE				
1		3UF7010-1AB00-0	BASIC UNIT SIMOCODE per V PB PRO V	

Note

¹⁾ Please use the PCS 7 AS configurator, since different versions of the PCS 7 AS 410-5H are available; e. g., 24V DC or 110/230V AC.

Notes regarding PROFIBUS DP:

- The maximum number of PROFIBUS DP slaves per master is 125 (typically 30 - 80)
- The maximum number of slaves per segment is 32 (including repeater and master), segments are separated from (diagnostics) repeaters

²⁾ ET 200M, DP/PA Link, Diagnostic Repeater and Compact FF Link require power supply for 24VDC.

³⁾ Additionally, signal modules are required for the connection of process signals. Type and number depend on the individual requirements.

⁴⁾ Type and number of bus modules depend on the signal modules used.

⁵⁾ Max. of 64 field devices per DP/PA Link

⁶⁾ Notes regarding FDC 157-0:

- Max. of 5 FDC 157-0 DP/PA couplers in a DP/PA link
- Max. of 31 field devices per FDC 157-0. (typically 20 - 25)
- The maximum current supplied from FDC 157-0 is 1,000 mA
- The maximum PA segment length is 1,900 m (typically 500 - 1,000 m)

⁷⁾ With an existing PDM V9.1 license that includes routing, only one additional license is needed for FF communication. You can find this optional license in the PCS 7 catalog.

⁸⁾ Notes regarding Compact FF Link.

- Max. of 31 field devices per FF segment. (typically 8 - 12)
- Max. Power supplied by Compact FF Link, 500mA
- The maximum FF segment length is 1,900 m (typically 500 - 1,000 m)

11.2 Single optical DP-PA / DP-FF Fieldbus

This configuration is an optical PROFIBUS DP system with four optical link modules. The optical part of the PROFIBUS DP system can be set up as a simple line or as a ring. When connecting devices to high-availability automation systems, a distinction is made between two variants.

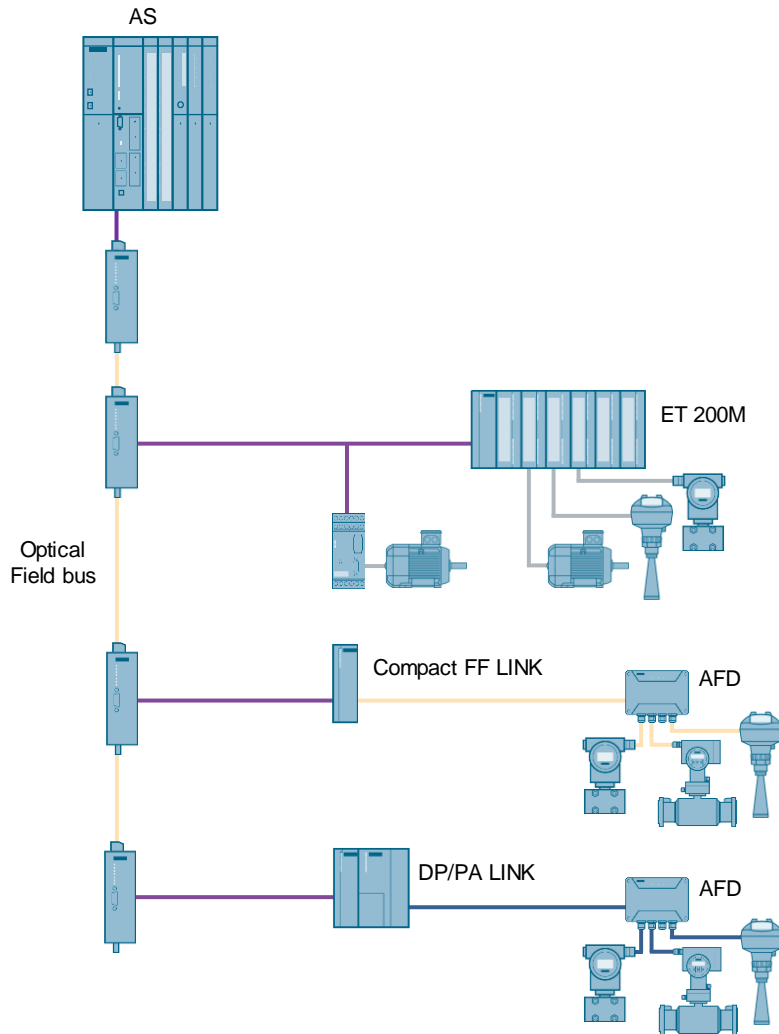

Bill of materials

Required	Optional	Article number	Product description	Note
Automation system				
1		6ES7654-6CL03-3BF0	SIMATIC PCS 7 SINGLE AS, CPU 410-5H, SYSTEM EXPANSIONS CARD 500 PO, AS RT PO 100, CP443-1IE, UR2 ALU RACK, UC 120/230V 10A POWER SUPPLY	1)
		24 V DC power supply	Redundant power supply	Chapter 17.2
OPTICAL FIELDBUS				
4		6GK1503-3CB00	PROFIBUS OLM/G12 V4.0 OPTICAL LINK MODULE	2)
ET 200M				
1		6ES7153-2BA10-0XB0	SIMATIC DP, ET 200M INTERFACE IM 153-2 HIGH FEATURE FOR MAX. 12 S7-300 MODULES	3) 4)
1		6ES7195-7HA00-0XA0	SIMATIC DP, BUS UNIT FOR ET200M	
1		6ES7195-7HB00-0XA0	SIMATIC DP, BUS UNIT FOR ET200M F. THE INTEGR.OF TWO 40 MM WIDE I/O SUBMODULES	5)
DP/PA LINK				
1		6ES7153-2BA70-0XB0	SIMATIC DP, INTERFACE DP/PA-LINK A. ET200M IM153-2 HF	3) 6)
1		6ES7157-0AC85-0XA0	SIMATIC DP, FIELD DEVICE LINK DP/PA COUPLER FDC 157-0 NON EX-VERSION	7)
1		6ES7195-7HA00-0XA0	SIMATIC DP, BUS UNIT FOR ET200M F. THE INTEGR.OF 1 PS A.1 IM153	
1		6ES7195-7HF80-0XA0	SIMATIC DP, BUS UNIT BM DP/PA FOR EXPANDED TEMPERATURE RANGE SUBMODULE FOR DP/PA COUPLER	
1		6ES7157-0AG81-0XA0	ACT. FIELD DISTRIBUTOR AFD FOR PROFIBUS PA RING	
Compact FF LINK				
1		6ES7658-3MD68-0YA5	SOFTWARE SIMATIC PDM PCS 7-FF V9.1 (100 TAGS)	8)
1		6ES7655-5BA00-0AB0	SIMATIC COMPACT FF LINK COMBINATION OF DP/FF LINK AND FF COUPLER	3) 9)
SIMOCODE				
1		3UF7010-1AB00-0	BASIC UNIT SIMOCODE per V PB PRO V	

Note

¹⁾ Please use the PCS 7 AS configurator, since different versions of the PCS 7 AS 410-5H are available; e. g., 24V DC or 110/230V AC.

Notes regarding PROFIBUS DP:

- The maximum number of PROFIBUS DP slaves per master is 125 (typically 30 - 80)
- The maximum number of slaves per segment is 32 (including repeater and master), segments are separated from (diagnostics) repeaters

²⁾ OLM/G12 establishes a fault-tolerant PROFIBUS DP ring. OLM/G12 needs a 24 V DC power supply.

³⁾ ET 200M, DP/PA Link, Diagnostic Repeater and Compact FF Link require power supply for 24VDC.

⁴⁾ Additionally, signal modules are required for the connection of process signals. Type and number depend on the individual requirements.

⁵⁾ Type and number of bus modules depend on the signal modules used.

⁶⁾ Max. of 64 field devices per DP/PA Link

⁷⁾ Notes regarding FDC 157-0:

- Max. of 5 FDC 157-0 DP/PA couplers in a DP/PA link
- Max. of 31 field devices per FDC 157-0. (typically 20 - 25)
- The maximum current supplied from FDC 157-0 is 1,000 mA
- The maximum PA segment length is 1,900 m (typically 500 - 1,000 m)

⁸⁾ With an existing PDM V9.1 license that includes routing, only one additional license is needed for FF communication. You can find this optional license in the PCS 7 catalog.

⁹⁾ Notes regarding Compact FF Link.

- Max. of 31 field devices per FF segment. (typically 8 - 12)
- Max. Power supplied by Compact FF Link, 500mA
- The maximum FF segment length is 1,900 m (typically 500 - 1,000 m)

11.3 Redundant DP-PA / DP-FF Fieldbus

This configuration is a redundant PROFIBUS DP system. The network transitions are also redundant with two DP/PA links or Compact FF links each.

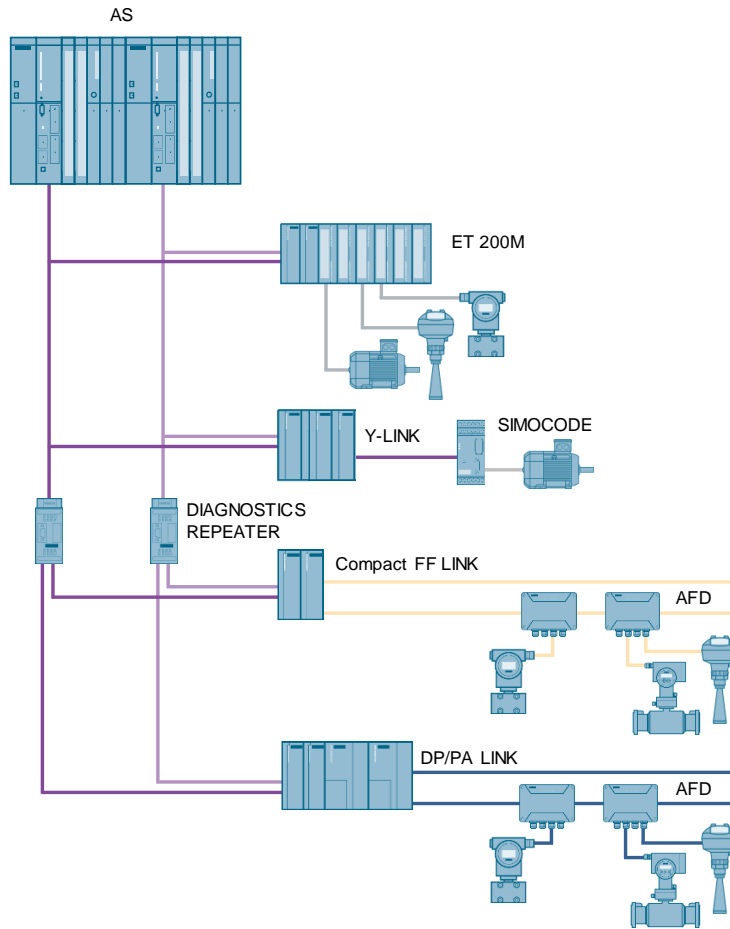

© Siemens AG 2019. All rights reserved.

Bill of materials

Required	Optional	Article number	Product description	Note
Automation system				
1		6ES7656-6CL33-1CF0	SIMATIC PCS 7 REDUNDANCY AS, 2X CPU 410-5H, 2 DP-MODULE, 2X PROFINET-IO, SYSTEM EXPANSION CARD 500, AS RT PO 100, 2 X 2 10M SYNC-MODULES AND 2 X 1M FO, 2 X CP443-1 IE/PN, 1 X UR2-H ALU RACK, 2 X UC 120/230V 10A RED. POWER SUPPLY	1)
2		6GK7443-5DX05-0XE0	COMMUNICATION PROCESSOR CP443-5 EXTENDED	2)

Required	Optional	Article number	Product description	Note
		24 V DC power supply	Redundant power supply	Chapter 17.2
ET 200M				
2		6ES7153-2BA10-0XB0	SIMATIC DP, ET 200M INTERFACE IM 153-2 HIGH FEATURE FOR MAX. 12 S7-300 MODULES	3) 4)
1		6ES7195-7HD10-0XA0	SIMATIC DP, BUS UNIT FOR ET200M FOR INTEGRATING 2 IM153-2 RED.	
1		6ES7195-7HB00-0XA0	SIMATIC DP, BUS UNIT FOR ET200M F. THE INTEGR.OF TWO 40 MM WIDE I/O SUBMODULES	5)
Y LINK				
1		6ES7197-1LA12-0XA0	SIMATIC S7-400H, Y-LINK FOR CONNECTING SINGLE-CHANNEL DP SLAVES TO S7-400H AND AS 410H	3)
DIAGNOSTICS REPEATER				
	2	6ES7972-0AA02-0XA0	SIMATIC DP, RS485 DIAGNOSTICS REPEATER	3)
DP/PA LINK				
2		6ES7153-2BA70-0XB0	SIMATIC DP, INTERFACE DP/PA-LINK A. ET200M IM153-2 HF	6)
2		6ES7157-0AC85-0XA0	SIMATIC DP, FIELD DEVICE LINK DP/PA COUPLER FDC 157-0 NON EX-VERSION	7)
1		6ES7195-7HD80-0XA0	SIMATIC DP, BUS UNIT BM IM 157 FOR EXPANDED TEMPERATURE RANGE	
1		6ES7195-7HG80-0XA0	SIMATIC DP, BUS COUPLE BM DP/PA FOR 2 FDC 157-0 FOR REDUNDANT OPERATION	
2		6ES7157-0AG81-0XA0	ACT. FIELD DISTRIBUTOR AFD FOR PROFIBUS PA RING	
1		6ES7157-0AG80-1XA1	10 protective caps for the unused connections on AFD	
Compact FF LINK				
1		6ES7658-3MD68-0YA5	SOFTWARE SIMATIC PDM PCS 7-FF V9.1 (100 TAGS)	8)
1		6ES7655-5EF00-0AA0	SIMATIC DP, BUS MODULE FOR INTEGRATING OF 2 COMPACT FF LINK IN REDUNDANT OPERATION	
2		6ES7655-5BA00-0AB0	SIMATIC COMPACT FF LINK COMBINATION OF DP/FF LINK AND FF COUPLER	3) 9)
2		6ES7157-0AG81-0XA0	ACTIVE FIELD DISTRIBUTOR AFD4 FOR FF RING	
SIMOCODE				
1		3UF7010-1AB00-0	BASIC UNIT SIMOCODE per V PB PRO V	

Note

- 1) Please use the PCS 7 AS configurator, since different versions of the PCS 7 AS 410-5H are available; e. g., 24V DC or 110/230V AC.
- 2) Notes regarding CP443-5 Extended:
 - The maximum number of PROFIBUS DP slaves per master is 125 (typically 30 - 80)
 - The maximum number of slaves per segment is 32 (including repeater and master), segments are separated from (diagnostics) repeaters
- 3) ET 200M, DP/PA Link, Y-LINK Diagnostic Repeater and Compact FF Link require a 24VDC power supply.
- 4) Additionally, signal modules are required for the connection of process signals. Type and number depend on the individual requirements.
- 5) Type and number of bus modules depend on the signal modules used.
- 6) Max. of 64 field devices per DP/PA Link
- 7) Notes regarding FDC 157-0:
 - Max. of one pair of redundant FDC 157-0s per DP/PA link and 3 single FDC 157-0
 - Max. of 31 field devices per redundant pair of FDC 157-0 (typically 20 - 25)
 - The maximum current supplied from FDC 157-0 is 1,000 mA
 - The maximum PA segment length is 1,900 m (typically 500 - 1,000 m)
- 8) With an existing PDM V9.1 license that includes routing, only one additional license is needed for FF communication. You can find this optional license in the PCS 7 catalog.
- 9) Notes regarding Compact FF Link:
 - Max. of 31 field devices per FF segment. (typically 8 - 12)
 - Max. Power supplied by Compact FF Link, 500mA
 - The maximum FF segment length is 1,900 m (typically 500 - 1,000 m)

11.4 Redundant optical DP-PA / DP-FF Fieldbus

This configuration is a redundant, optical PROFIBUS DP system with optical link modules. The network transitions are also redundant with two DP/PA links or Compact FF links each.

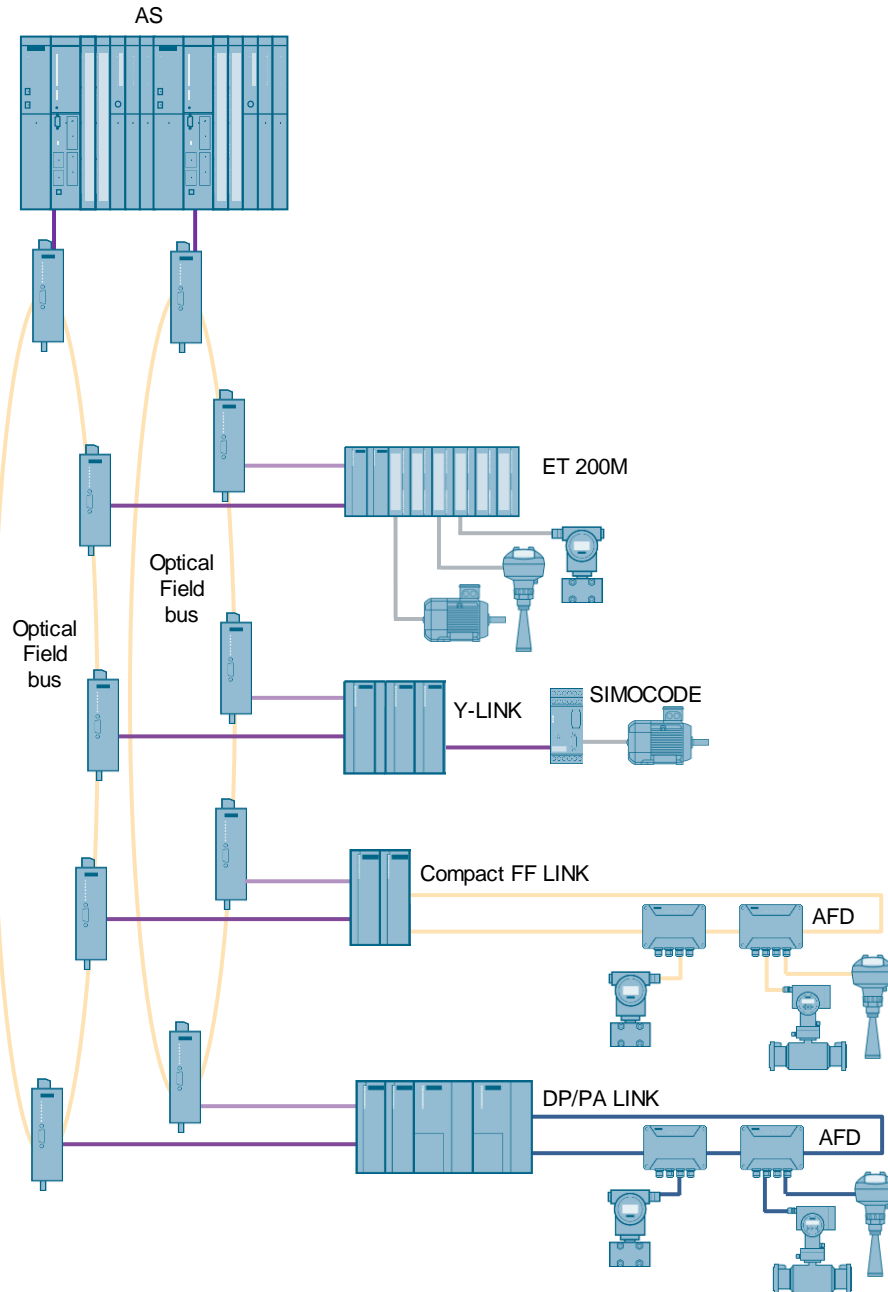

Bill of materials

Required	Optional	Article number	Product description	Note
Automation system				
1		6ES7656-6CL33-1CF0	SIMATIC PCS 7 REDUNDANCY AS, 2X CPU 410-5H, 2 DP-MODULE, 2X PROFINET-IO, SYSTEM EXPANSION CARD 500, AS RT PO 100, 2 X 2 10M SYNC-MODULES AND 2 X 1M FO, 2 X CP443-1 IE/PN, 1 X UR2-H ALU RACK, 2 X UC 120/230V 10A RED. POWER SUPPLY	1)
	2	6GK7443-5DX05-0XE0	COMMUNICATION PROCESSOR CP443-5 EXTENDED	2)
		24 V DC power supply	Redundant power supply	Chapter 17.2
OPTICAL FIELDBUS				
10		6GK1503-3CB00	PROFIBUS OLM/G12 V4.0 OPTICAL LINK MODULE	8)
ET 200M				
2		6ES7153-2BA10-0XB0	SIMATIC DP, ET 200M INTERFACE IM 153-2 HIGH FEATURE FOR MAX. 12 S7-300 MODULES	3) 4)
1		6ES7195-7HD10-0XA0	SIMATIC DP, BUS UNIT FOR ET200M FOR INTEGRATING 2 IM153-2 RED.	
1		6ES7195-7HB00-0XA0	SIMATIC DP, BUS UNIT FOR ET200M F. THE INTEGR. OF TWO 40 MM WIDE I/O SUBMODULES	5)
Y LINK				
2		6ES7197-1LA11-0XA0	SIMATIC S7-400H, Y-LINK FOR CONNECTING SINGLE-CHANNEL DP SLAVES TO S7-400H	3)
DP/PA LINK				
2		6ES7153-2BA70-0XB0	SIMATIC DP, INTERFACE DP/PA-LINK A. ET200M IM153-2 HF	3) 6)
2		6ES7157-0AC85-0XA0	SIMATIC DP, FIELD DEVICE LINK DP/PA COUPLER FDC 157-0 NON EX-VERSION	7)
1		6ES7195-7HD80-0XA0	SIMATIC DP, BUS UNIT BM IM 157 FOR EXPANDED TEMPERATURE RANGE	
1		6ES7195-7HG80-0XA0	SIMATIC DP, BUS COUPLE BM DP/PA FOR 2 FDC 157-0 FOR REDUNDANT OPERATION	
2		6ES7157-0AG81-0XA0	ACT. FIELD DISTRIBUTOR AFD FOR PROFIBUS PA RING	
1		6ES7157-0AG80-1XA1	10 PROTECTIVE CAPS FOR THE UNUSED CONNECTIONS ON AFD	
Compact FF LINK				
1		6ES7658-3MD68-0YA5	SOFTWARE SIMATIC PDM PCS 7-FF V9.1 (100 TAGS)	8)
1		6ES7655-5EF00-0AA0	SIMATIC DP, BUS MODULE FOR INTEGRATING OF 2 COMPACT FF LINK IN REDUNDANT OPERATION	
2		6ES7655-5BA00-0AB0	SIMATIC COMPACT FF LINK COMBINATION OF DP/FF LINK AND FF COUPLER	3) 9)
2		6ES7157-0AG81-0XA0	ACTIVE FIELD DISTRIBUTOR AFD4 FOR FF RING	

Required	Optional	Article number	Product description	Note
		SIMOCODE		
		3UF7010-1AB00-0	BASIC UNIT SIMOCODE PER V PB PRO V	

Note

- ¹⁾ Please use the PCS 7 AS configurator, since different versions of the PCS 7 AS 410-5H are available; e. g., 24V DC or 110/230V AC.
- ²⁾ Notes regarding CP443-5 Extended:
- The maximum number of PROFIBUS DP slaves per master is 125 (typically 30 - 80)
 - The maximum number of slaves per segment is 32 (including repeater and master), segments are separated from (diagnostics) repeaters
- ³⁾ ET 200M, DP/PA Link, Y-LINK Diagnostic Repeater and Compact FF Link require a 24VDC power supply.
- ⁴⁾ Additionally, signal modules are required for the connection of process signals. Type and number depend on the individual requirements.
- ⁵⁾ Type and number of bus modules depend on the signal modules used.
- ⁶⁾ Max. of 64 field devices per DP/PA Link
- ⁷⁾ Notes regarding FDC 157-0:
- Max. of one pair of redundant FDC 157-0s per DP/PA link and 3 single FDC 157-0
 - Max. of 31 field devices per redundant pair of FDC 157-0 (typically 20 - 25)
 - The maximum current supplied from FDC 157-0 is 1,000 mA
 - The maximum PA segment length is 1,900 m (typically 500 - 1,000 m)
- ⁸⁾ With an existing PDM V9.1 license that includes routing, only one additional license is needed for FF communication. You can find this optional license in the PCS 7 catalog.
- ⁹⁾ Notes regarding Compact FF Link:
- Max. of 31 field devices per FF segment. (typically 8 - 12)
 - Max. Power supplied by Compact FF Link, 500mA
 - The maximum FF segment length is 1,900 m (typically 500 - 1,000 m)

11.5 PROFINET Fieldbus with a standard automation system

This configuration is a standard automation system with PROFINET, PROFIBUS DP and PROFIBUS PA. The network transition to PROFIBUS DP is realized with IE/PB LINK PN IO and the integration of the PROFIBUS PA field devices via the Compact Field Unit PA.

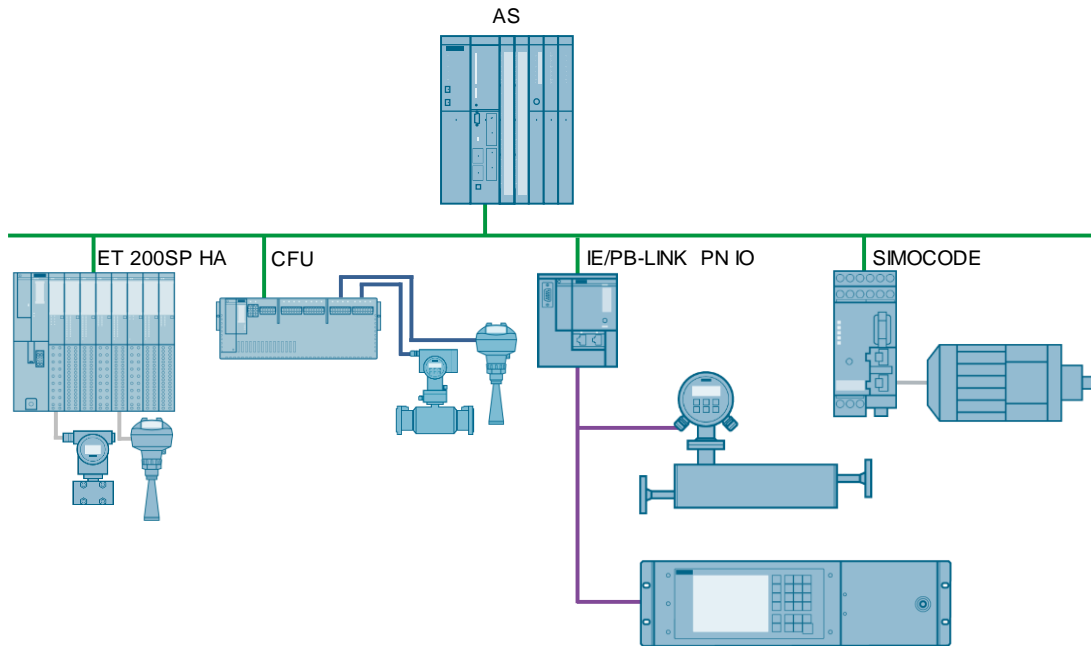

© Siemens AG 2019. All rights reserved.

Bill of materials

Required	Optional	Article number	Product description	Note
Automation system				
1		6ES7654-6CL03-3BF0	SIMATIC PCS 7 SINGLE AS, CPU 410-5H, SYSTEM EXPANSIONS CARD 500 PO, AS RT PO 100, CP443-1IE, UR2 ALU RACK, UC 120/230V 10A POWER SUPPLY	1) 2)
		24 V DC power supply	Redundant power supply	Chapter 17.2

Required	Optional	Article number	Product description	Note
ET 200SP HA				
1		6DL1155-6AU00-0PM0	INTERFACE MODULE IM 155-6 PN HA	3) 4)
1		6DL1193-6BH00-0SM0	SUBRACK MODULE (INTERFACE MODULE – SINGLE)	
1		6DL1193-6GA00-0NN0	SUBRACK MODULE 2X	5)
1		6DL1193-6TP00-0DH1	TERMINAL BLOCK (SINGLE)	5)
1		6DL1193-6PA00-0AA0	SERVER MODULE	
1		6DL1193-6AF00-0AA0	PROFINET BUSADAPTER FAST CONNECT	6)
Compact Field Unit				
1		6ES7655-5PX11-0XX0	COMPACT FIELD UNIT PA	3)
1		6DL1193-6AF00-0AA0	PROFINET BUSADAPTER FAST CONNECT	6)
Gateway to PROFIBUS				
1		6GK1411-5AB10	IE/PB LINK PN IO	3) 7)
SIMOCODE				
1		3UF7011-1AB00-0	SIMOCODE pro V PN	

Note

- ¹⁾ Please use the PCS 7 AS configurator, since different versions of the PCS 7 AS 410-5H are available; e. g., 24V DC or 110/230V AC. It is not possible to operate PROFINET networks on the external Ethernet CP443-1.
- ²⁾ Max. of 250 devices per onboard CPU interface.
- ³⁾ IM 155-6, Compact Field Unit PA and IE/PB LINK PN IO require power supply for 24VDC.
- ⁴⁾ Additionally, signal modules are required for the connection of process signals. Type and number depend on the individual requirements.
- ⁵⁾ Type and number of subrack modules and terminal blocks depend on the signal modules used.
- ⁶⁾ Alternatively, bus adapters can be used for optical connection via fiber-optic cables.
- ⁷⁾ Only compact devices are supported as PROFIBUS DP nodes and lower-level PROFIBUS PA nodes (PA couplers).

Note

In the configuration above, the network topology has not been taken into account, as it depends among other things on the number of devices and local conditions.

Recommended and tested topologies can be found as PROFINET blueprints in the application example "PROFINET in Process Automation with SIMATIC PCS 7":

<https://support.industry.siemens.com/cs/ww/en/view/72887082>

11.6 PROFINET Fieldbus with a highly available automation system – simple system redundancy S2

This configuration is a highly available automation system with PROFINET. To increase the availability of the devices, the PROFINET network is set up as an open ring.

Connecting to a closed ring with MRP is also possible, but would have more disadvantages than advantages, since the reconfiguration of the MRP ring is slower, among other things, than the switching time of the H-system in cases error.

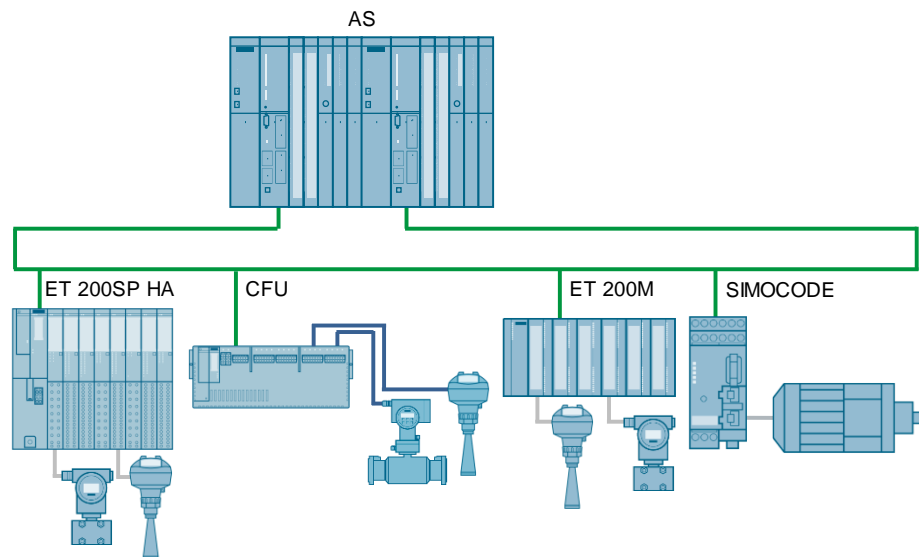

Bill of materials

Required	Optional	Article number	Product description	Note
Automation system				
1		6ES7656-6CL33-1CF0	SIMATIC PCS 7 REDUNDANCY AS, 2X CPU 410-5H, 2 DP-MODULES, 2X PROFINET-IO, SYSTEM EXPANSION CARD 500 PO, AS RT PO 100, 2 X 2 10M SYNC-MODULES AND 2 X 1M FO, 2 X CP443-1	1) 2) 3)
		24 V DC power supply	Redundant power supply	Chapter 17.2
ET 200SP HA				
1		6DL1155-6AU00-0PM0	INTERFACE MODULE IM 155-6 PN HA	4) 5)
1		6DL1193-6BH00-0SM0	SUBRACK MODULE (INTERFACE MODULE – SINGLE)	
1		6DL1193-6GA00-0NN0	SUBRACK MODULE 2X	6)
1		6DL1193-6TP00-0DH1	TERMINAL BLOCK (SINGLE)	6)
1		6DL1193-6PA00-0AA0	SERVER MODULE	
1		6DL1193-6AF00-0AA0	PROFINET BUSADAPTER FAST CONNECT	8)

Required	Optional	Article number	Product description	Note
Compact Field Unit				
1		6ES7655-5PX11-0XX0	COMPACT FIELD UNIT PA	4)
1		6DL1193-6AF00-0AA0	PROFINET BUSADAPTER FAST CONNECT	8)
ET 200M				
1		6ES7153-4BA00-0XB0	SIMATIC DP, ET 200M INTERFACE IM 153-4 PN IO HIGH FEATURE FOR MAX. 12 S7-300 MODULES	4) 5)
1		6ES7195-7HA00-0XA0	SIMATIC DP, BUS UNIT FOR ET 200M	
1		6ES7195-7HB00-0XA0	SIMATIC DP, BUS UNIT FOR ET 200M F. THE INTEGR.OF TWO 40 MM WIDE I/O SUBMODULES	7)
Gateway to PROFIBUS				
1		6GK1411-5AB10	IE/PB LINK PN IO	4) 9)
SIMOCODE				
1		3UF7011-1AB00-0	SIMOCODE pro V PN	

Note

- 1) Please use the PCS 7 AS configurator, since different versions of the PCS 7 AS 410-5H are available; e. g., 24V DC or 110/230V AC. It is not possible to operate PROFINET networks on the external Ethernet CP443-1.
- 2) Only devices that support system redundancy S2 can be operated redundantly on the H-System. Devices that do not support system redundancy can only be assigned to one H CPU.
- 3) Max. of 250 devices per onboard CPU interface.
- 4) ET 200SP HA, ET 200M, Compact Field Unit PA and IE/PB LINK PN IO require power supply for 24VDC.
- 5) Additionally, signal modules are required for the connection of process signals. Type and number depend on the individual requirements.
- 6) Type and number of subrack modules and terminal blocks depend on the signal modules used.
- 7) Type and number of bus modules depend on the signal modules used.
- 8) Alternatively, bus adapters can be used for optical connection via fiber-optic cables.
- 9) Only compact devices are supported as PROFIBUS DP nodes and lower-level PROFIBUS PA nodes (PA couplers).

11.7 Redundant PROFINET Fieldbus with a highly available automation system - R1

This configuration is a highly available automation system with a redundant PROFINET configuration R1. In this configuration, the automation system, network and interface modules are configured redundantly in order to achieve the highest possible level of availability when connecting the decentralized peripherals.

Optionally, the peripheral modules of the ET 200SP HA can also be provided with redundant peripheral modules. Counter-rotating cabling is used. This ensures that all other nodes remain available in the event of a failure or station replacement.

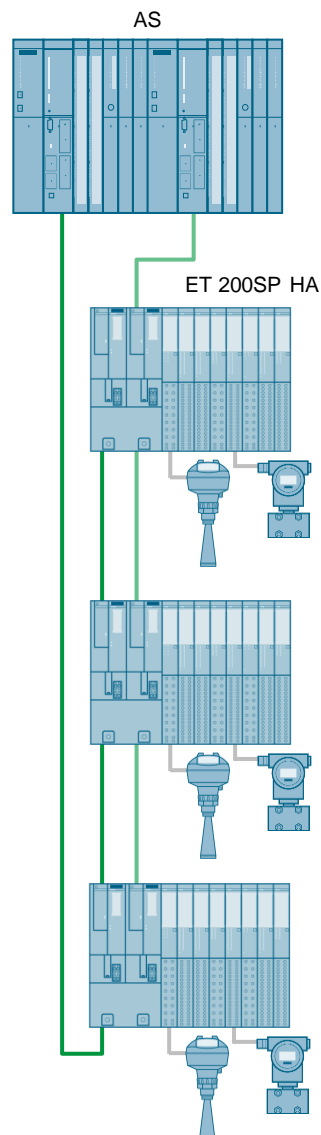

Bill of materials

Required	Optional	Article number	Product description	Note
Automation system				
1		6ES7656-6CL33-1CF0	SIMATIC PCS 7 REDUNDANCY AS, 2X CPU 410-5H, 2 DP-MODULES, 2X PROFINET-IO, SYSTEM EXPANSION CARD 500 PO, AS RT PO 100, 2 X 2 10M SYNC-MODULES AND 2 X 1M FO, 2 X CP443-1	1) 2) 3) 4)
		24 V DC POWER SUPPLY	Redundant power supply	Chapter 17.2
ET 200SP HA				
6		6DL1155-6AU00-0PM0	INTERFACE MODULE IM 155-6 PN HA	5) 6)
3		6DL1193-6BH00-0RM0	SUBRACK MODULE (INTERFACE MODULE – REDUNDANT)	
3		6DL1193-6GA00-0NN0	SUBRACK MODULE 2X	7)
3		6DL1193-6TP00-0DH1	TERMINAL BLOCK (SINGLE)	7)
3		6DL1193-6PA00-0AA0	SERVER MODULE	
6		6DL1193-6AF00-0AA0	PROFINET BUSADAPTER FAST CONNECT	8)

Note

- 1) Please use the PCS 7 AS configurator, since different versions of the PCS 7 AS 410-5H are available; e. g., 24V DC or 110/230V AC. It is not possible to operate PROFINET networks on the external Ethernet CP443-1.
- 2) Only devices that support at least system redundancy S2 can be operated redundantly on the H-System. Devices that do not support system redundancy can only be assigned to one H CPU.
- 3) Max. of 64 R1 devices per onboard CPU interface. In combination with S2-Devices a maximum of 250 per CPU onboard interface.
- 4) An additional license is required for connecting R1 devices.
- 5) ET 200SP HA needs a 24V DC power supply.
- 6) Additionally, signal modules are required for the connection of process signals. Type and number depend on the individual requirements.
- 7) Type and number of subrack modules and terminal blocks depend on the signal modules used.
- 8) Alternatively, bus adapters can be used for optical connection via fiber-optic cables.

Note

The choice of network topology depends, among other things, on the number of devices and local conditions.

Recommended and tested topologies can be found as PROFINET blueprints in the application example "PROFINET in Process Automation with SIMATIC PCS 7":

<https://support.industry.siemens.com/cs/ww/en/view/72887082>

12 SIMATIC PDM

SIMATIC PDM

SIMATIC PDM is a universal tool for parameter assignment, diagnostics, commissioning, servicing and maintenance of field devices. Furthermore, the Maintenance Station displays the PDM diagnostic data of field devices.

PDM is fully integrated in the SIMATIC PCS 7 Engineering System.

SIMATIC PDM V9.1 supports communication with devices on PROFINET, PROFIBUS DP, PROFIBUS PA, FOUNDATION Fieldbus H1 and HART (ET 200M, ET200SP HA or ET200iSP modules, modem, RS 232).

The open technologies EDDL (Electronic Device Description Language) and FDI (Field Device Integration) are used to integrate these devices.

Note

In the respective PDM delivery release information, you will find a list of devices supported by a PDM version and profiles.

SIMATIC PDM supports stand-alone operation and can be integrated into STEP 7 / PCS 7.

PDM is installed in the Engineering System of medium to large system configurations, with or without a redundant server, and connected to field devices over the Ethernet system bus and the routing functionality of the automation system.

Local service and parameter assignment stations on the fieldbus

PDM can also be used for stand-alone operation. The stand-alone version is used on a standard computer without STEP 7 or PCS 7 installation. This computer is connected to the PROFINET or PROFIBUS DP fieldbus. This configuration allows you to carry out parameter assignment and maintenance tasks for HART, PROFIBUS PA, PROFIBUS DP and PROFINET. PROFIBUS DP/PA devices can be accessed from the LifeList.

HART devices can be accessed via ET200 modules, HART modems (point-to-point) or HART multiplexers.

Local service and parameter assignment stations on the plant bus

With SIMATIC PDM on a Field PG, you can use the routing functionality to access the field devices directly from the plant bus and perform maintenance, service and parameterization tasks. The Field PG is particularly suitable for rugged day-to-day industrial use due to its robust construction.

Starter system

A SIMATIC PCS 7 BOX RTX ES/OS system with SIMATIC PDM is an economical solution for systems with up to 100 inputs and outputs.

Engineering and maintenance functions are accessible with SIMATIC PDM through the connections to HART, FOUNDATION Fieldbus, PROFIBUS PA, PROFIBUS DP and PROFINET devices.

Single user system (Single Station)

When using a single user system, PDM connects to field devices via the Ethernet plant bus and the routing functionality of the automation system. When using multi-engineering systems, PDM must be installed on all engineering systems where PDM is used.

Non-SIMATIC S7 master

Non-PCS 7 PROFIBUS DP masters can use the Ethernet / PROFINET to PROFIBUS DP (IE/PB Link) interfaces, which allow a seamless connection to lower-level field devices. By integrating PDM into STEP 7, more field devices can be managed comprehensively and their data can be archived and versioned just like in SIMATIC PCS 7.

SIMATIC PDM server Option

This option licenses and enables the following applications:

- Access to SIMATIC PDM functions via a web browser. The connection from the PDM client PC is only possible with Internet Explorer V10, V11 or Chrome.
- Access with a maintenance client to the SIMATIC PDM parameterization interface for the selected field device. The call is carried out via the PDM button in the Maintenance Faceplate.

12.1 Local service and parameter assignment station on the fieldbus

In this configuration, the system has one laptop and SIMATIC PDM in stand-alone operation. The field devices are connected by means of PROFINET or PROFIBUS.

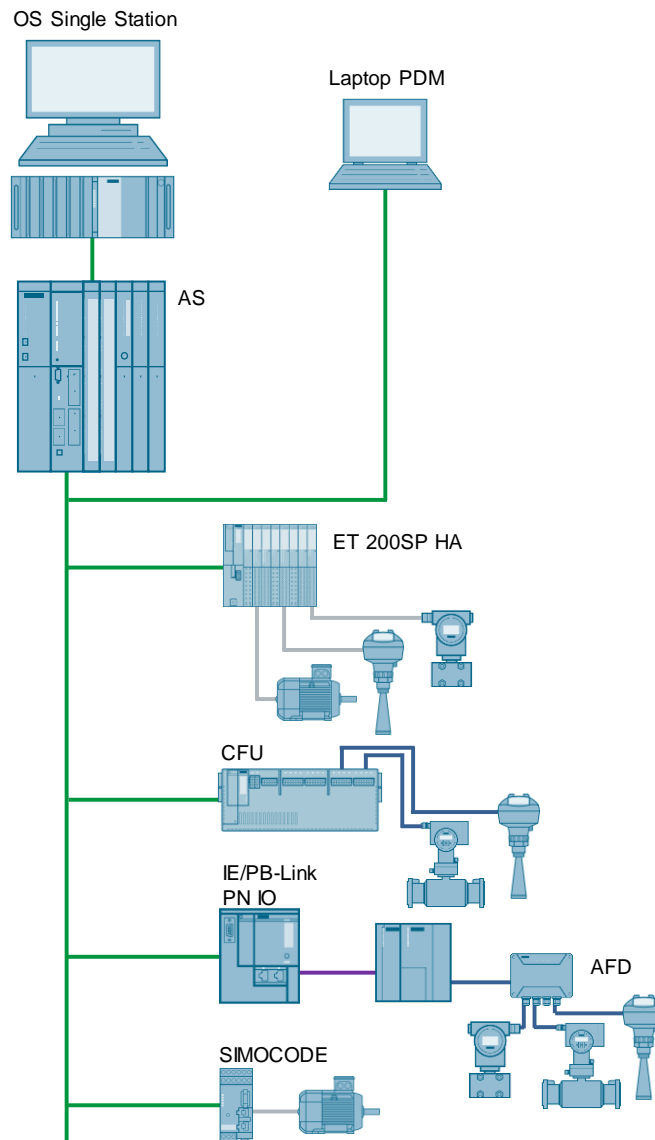

Bill of materials

Required	Optional	Article number	Product description	Note
Laptop PDM				
	1	6GK1571-0BA00-0AA0	SIMATIC S7, PC ADAPTER USB NETWORK CARD	1)
	1	6GK1561-2AA00	CP5612 COMMUNICATION PROCESSOR PCI CARD (32 BIT / 64 BIT)	1)
1		6ES7658-3AB68-0YA5	SOFTWARE SIMATIC PDM BASIC V9.1 (4 TAGS)	2)
	1	6ES7658-3NX68-2YB5	SIMATIC PDM EXTENDED V9.1	
	1	6ES7658-3TX68-2YB5	SIMATIC PDM SERVER V9.1	
	1	6ES7658-3UA00-2YB5	SIMATIC PDM 1 CLIENT	3)
	1	6ES7658-7BX61-0YA0	SIMATIC LOGON SERVICE V1.6	

Note

The SIMATIC PCS 7 single user system is not listed.

1) USB network card for laptop use. Use CP5612 (or other approved network cards) for desktop PC systems.

Only for connection to the PROFIBUS DP Fieldbus.

2) The number of TAGs can be increased by means of cumulative TAG licenses.

3) The total number of PDM client licenses can be increased up to 30.

12.2 Local service and parameter assignment station on the fieldbus

In this configuration, the system has one Field PG and SIMATIC PDM in stand-alone operation. Field devices on PROFINET or PROFIBUS networks are connected via S7-CPU and a plant bus.

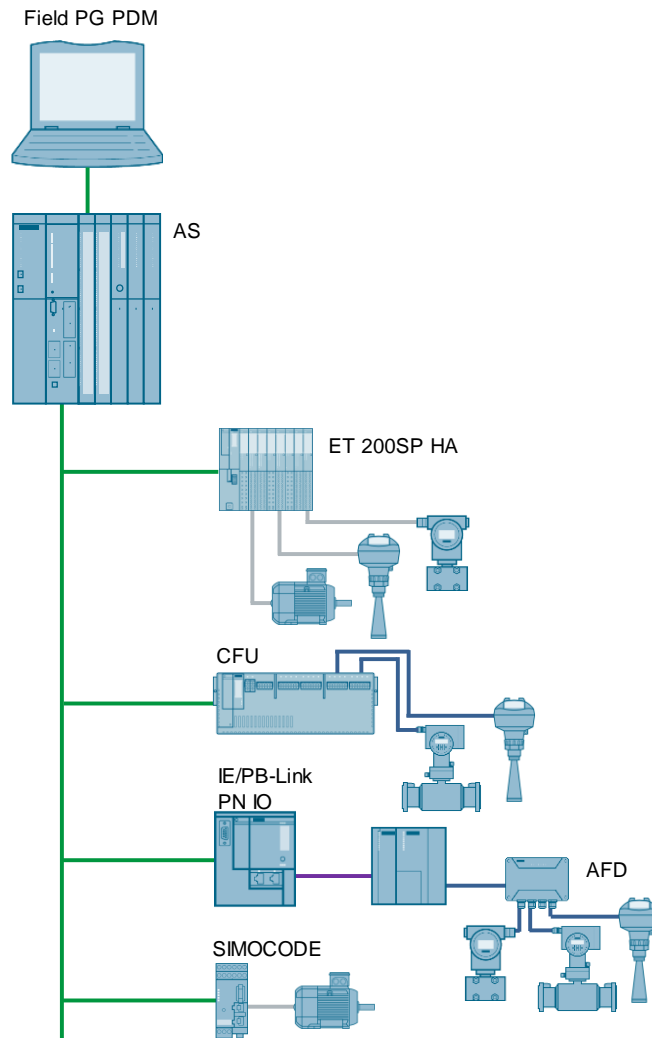

Bill of materials

Required	Optional	Article number	Product description	Note
Laptop PDM				
1		6ES7658-3JD68-0YA5	SOFTWARE SIMATIC PDM SERVICE V9.1 (50 TAGs)	1)
1		6ES7658-3CX68-2YB5	SOFTWARE SIMATIC PDM ROUTING V9.1	
	1	6ES7658-3NX68-2YB5	SIMATIC PDM EXTENDED V9.1	
	1	6ES7658-3TX68-2YB5	SIMATIC PDM SERVER V9.1	
	1	6ES7658-3UA00-2YB5	SIMATIC PDM 1 CLIENT	2)
	1	6ES7658-7BX61-0YA0	SIMATIC LOGON SERVICE V1.6	

Note

1) The number of TAGs can be increased by means of cumulative TAG licenses.

2) The total number of PDM client licenses can be increased up to 30.

12.3 SIMATIC PDM and PCS 7 Starter System

In this configuration, the system has one SIMATIC PCS 7 BOX RTX with integrated ES, AS, OS, and PDM. The field devices are connected by means of PROFINET or PROFIBUS DP.

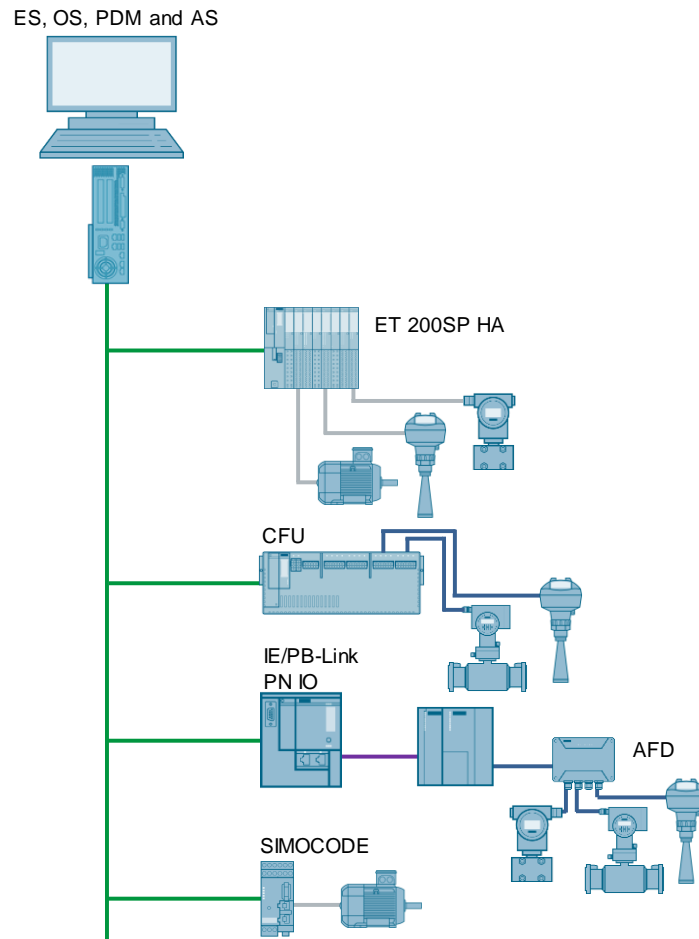

Bill of materials

Required	Optional	Article number	Product description	Note
Engineering Station, PDM, Operator Station and Automation System				
1		6ES7650-4BB10-3RA0	PCS 7 V9.0 BOX RTX ES/OS SYSTEM (WINAC RTX 2010), WINDOWS 7 ULTIMATE 32BIT, PROFINET ONBOARD, PCS 7 V9.0 PREINSTALLED	1) 3)
	1	6ES7652-0XD58-2YB5	SOFTWARE SIMATIC PCS 7 SFC VISUALIZATION V9.0	
	1	6ES7658-1CX58-2YA5	SOFTWARE SIMATIC PCS 7 VERSION CROSS MANAGER V9.0	
	1	6ES7658-1DX58-2YB5	SOFTWARE SIMATIC PCS 7 IMPORT EXPORT ASSISTANT V9.0	
	1	6ES7658-1FX58-2YA5	SOFTWARE SIMATIC PCS 7 VERSION TRAIL V9.0	
1		6ES7658-3LD68-0YA5	SOFTWARE SIMATIC PDM PCS 7 V9.1 (100 TAGS)	2)
	1	6ES7658-3QX68-2YB5	SOFTWARE SIMATIC PDM COMMUNICATION FOUNDATION FIELDBUS V9.1	3)
	1	6ES7658-3TX68-2YB5	SIMATIC PDM SERVER V9.1	
	1	6ES7658-3UA00-2YB5	SIMATIC PDM 1 CLIENT	4)
		24 V DC power supply	Buffered power supply	Chapter 17.5

Note

- 1) Please use the PCS 7 BOX configurator, as the PCS 7 BOX is available in different versions, e. g. 24V DC or 110/230V AC.
- 2) The number of TAGs can be increased by means of cumulative TAG licenses.
- 3) Optional for FOUNDATION Fieldbus communication.
- 4) The total number of PDM client licenses can be increased up to 30.

12.4 SIMATIC PDM and PCS 7 single user system

This configuration is a system in which the ES, OS, and PDM are used on one PC as a single user system. The connection to the field devices is made by means of the system bus.

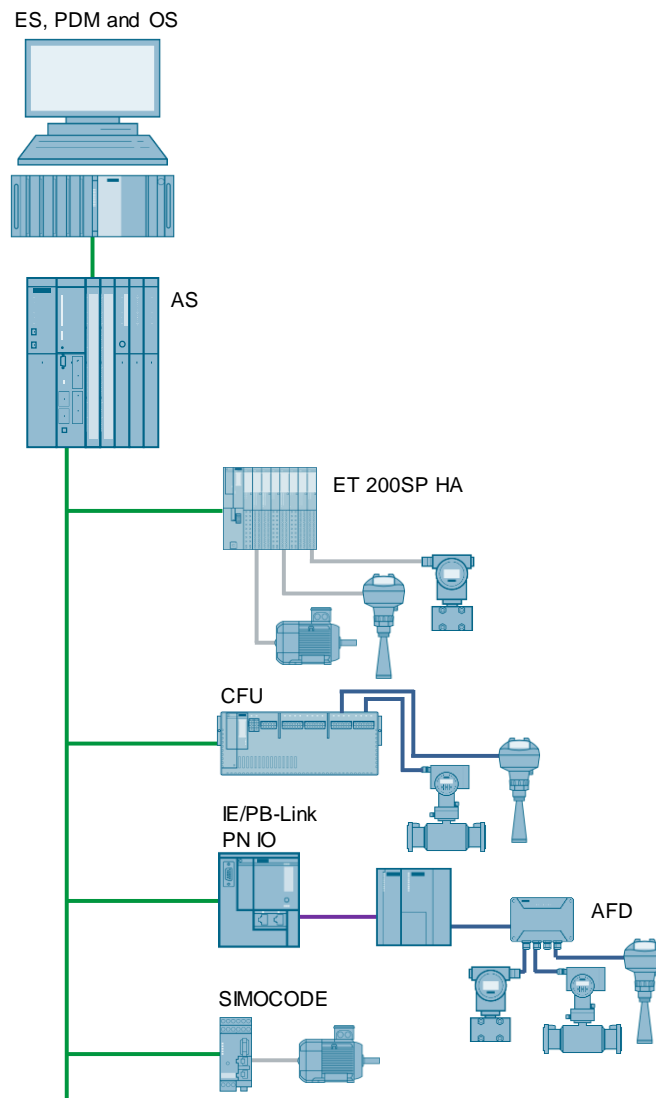

Bill of materials

Required	Optional	Article number	Product description	Note
Engineering Station, PDM, and Operator Station				
1		6ES7660-6DA10-3BA0	SIMATIC PCS 7 INDUSTRIAL WORKSTATION IPC847D, CORE I5, ES/OS SINGLESTATION, 500 GB HD SATA, 8GB DDR3, BCE, PCS 7 V9.0, WINDOWS 10 ENTERPRISE 2015 LTSB 64BIT	
1		6ES7651-5AA58-0YA0	SIMATIC PCS 7, SOFTWARE, ES SINGLE STATION V9.0 (AS/OS: 250 POs)	1)
	1	6ES7652-0XD58-2YB5	SOFTWARE SIMATIC PCS 7 SFC VISUALIZATION V9.0	
	1	6ES7658-1CX58-2YA5	SOFTWARE SIMATIC PCS 7 VERSION CROSS MANAGER V9.0	
	1	6ES7658-1DX58-2YB5	SOFTWARE SIMATIC PCS 7 IMPORT EXPORT ASSISTANT V9.0	
	1	6ES7658-1FX58-2YA5	SOFTWARE SIMATIC PCS 7 VERSION TRAIL V9.0	
1		6ES7658-3LD68-0YA5	SOFTWARE SIMATIC PDM PCS 7 V9.1 (100 TAGs)	3)
	1	6ES7658-3QX68-2YB5	SOFTWARE SIMATIC PDM Communication FOUNDATION FIELDBUS V9.1	4)
	1	6ES7658-3TX68-2YB5	SIMATIC PDM SERVER V9.1	
	1	6ES7658-3UA00-2YB5	SIMATIC PDM 1 CLIENT	6)
Automation system				
1		6ES7654-6CL03-3BF0	SIMATIC PCS 7 SINGLE AS, CPU 410-5H, SYSTEM EXPANSIONS CARD 500 PO, AS RT PO 100, CP443-1IE, UR2 ALU RACK, UC 120/230V 10A POWER SUPPLY	2) 5)
		24 V DC power supply	Redundant power supply	Chapter 17.2

Note

- 1) The number of POs can be increased later by means of extra volume licenses.
- 2) Please use the PCS 7 AS configurator, since different versions of the PCS 7 AS 410-5H are available; e. g., 24V DC or 110/230V AC.
- 3) The number of TAGs can be increased by means of cumulative TAG licenses.
- 4) Optional for FOUNDATION Fieldbus communication.
- 5) The following applies to each Standard CPU/CPU PN: If you use the PROFIBUS DP interface of the CPU for data record routing, you must configure this CPU in the HW config with firmware V5.1 or higher. If this is not the case, it needs a CP443-5 Ext PROFIBUS communications module to use PDM data record routing.
- 6) The number of PDM client licenses can be increased up to 30 in total.

12.5 SIMATIC PDM and PCS 7 OS client / OS server system

In this configuration, the system has one OS server and three OS clients. The ES and the SIMATIC PDM are configured on a separate PC.

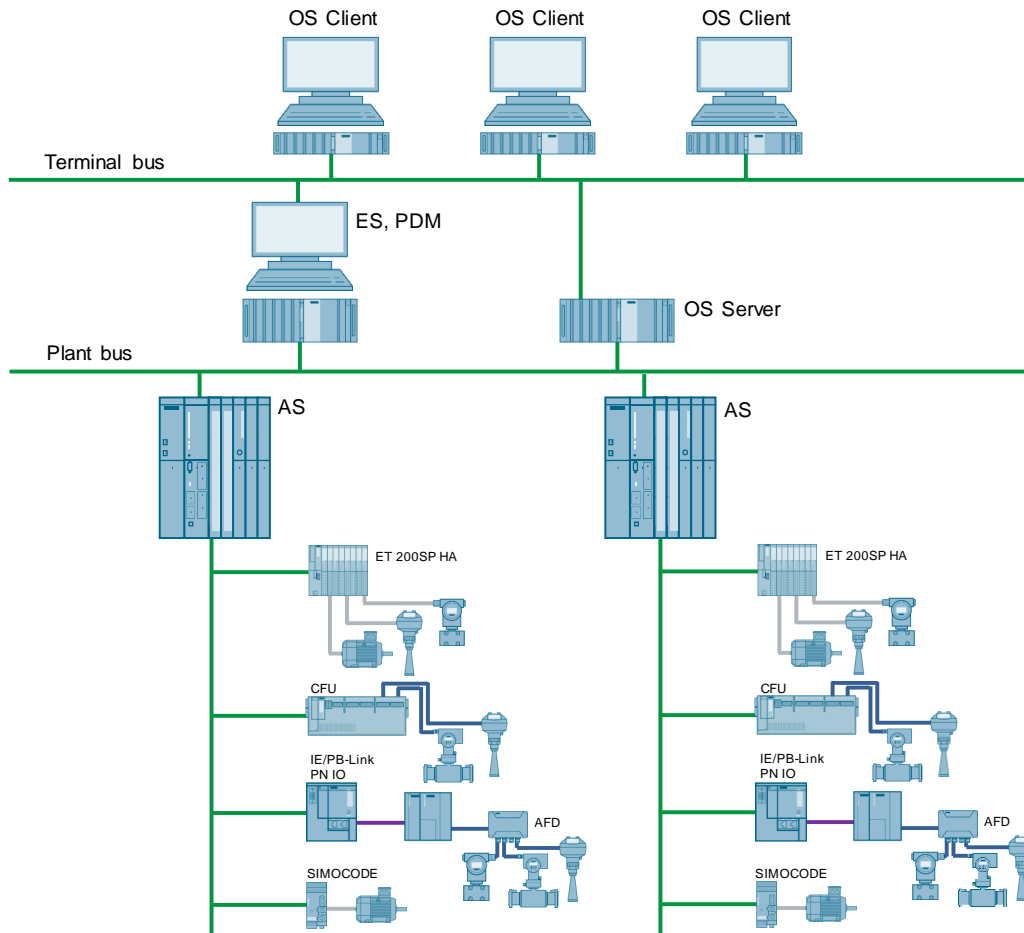

© Siemens AG 2019. All rights reserved.

Bill of materials

Required	Optional	Article number	Product description	Note
Engineering Station				
1		6ES7660-6DA10-3BA0	SIMATIC PCS 7 INDUSTRIAL WORKSTATION IPC847D, CORE I5, ES/OS SINGLESTATION, 500 GB HD SATA, 8GB DDR3, BCE, PCS 7 V9.0, WINDOWS 10 ENTERPRISE 2015 LTSP 64BIT	
1		6ES7658-5AX58-0YA5	SOFTWARE SIMATIC PCS 7 AS/OS ENGINEERING V9.0	

Required	Optional	Article number	Product description	Note
	1	6ES7658-1CX58-2YA5	SOFTWARE SIMATIC PCS 7 VERSION CROSS MANAGER V9.0	
	1	6ES7658-1FX58-2YA5	SOFTWARE SIMATIC PCS 7 VERSION TRAIL V9.0	
	1	6ES7658-1DX58-2YB5	SOFTWARE SIMATIC PCS 7 IMPORT EXPORT ASSISTANT V9.0	
1		6ES7658-3LD68-0YA5	SOFTWARE SIMATIC PDM PCS 7 V9.1 (100 TAGs)	3)
	1	6ES7658-3QX68-2YB5	SOFTWARE SIMATIC PDM Communication FOUNDATION FIELDBUS V9.1	4)
	1	6ES7658-3TX68-2YB5	SIMATIC PDM SERVER V9.1	
	1	6ES7658-3UA00-2YB5	SIMATIC PDM 1 CLIENT	6)
OS server				
1		6ES7660-6EC10-3EA0	SIMATIC PCS 7 INDUSTRIAL WORKSTATION IPC847D, CORE I5, OS-SERVER, RAID1 (2 X 1 TB HDD SATA, DATA MIRRORING), 8GB DDR3, BCE, PCS 7 V9.0, WIN SERVER 2012 R2 STANDARD EDITION INCL. 5 CLIENT 64BIT	
1		6ES7658-2BA58-0YA0	SOFTWARE SIMATIC PCS 7 OS-SERVER V9.0 (PO 100)	1)
OS client				
3		6ES7660-5FA08-3BA0	SIMATIC PCS 7 INDUSTRIAL WORKSTATION IPC647D, CORE I5, OS-CLIENT, 500 GB HD SATA, 4GB DDR3, PCS 7 V9.0, WINDOWS 10 ENTERPRISE 2015 LTSB 64BIT	
3		6ES7658-2CX58-0YB5	SOFTWARE SIMATIC PCS 7 OS-CLIENT V9.0	
	3	6ES7652-0XD58-2YB5	SOFTWARE SIMATIC PCS 7 SFC VISUALIZATION V9.0	
Automation system				
2		6ES7654-6CN03-3BF0	SIMATIC PCS 7 SINGLE AS, CPU 410-5H, 1X DP-MODULE, 2x PROFINET-IO, SYSTEM EXPANSION CARD 1000 PO, AS RT PO 100, CP443-1IE, UR2 ALU RACK, 1 X UC 120/230V 10A POWER SUPPLY	2) 5)
		24 V DC power supply	Redundant power supply	Chapter 17.2

Note

- 1) The number of POs can be increased later by means of extra volume licenses.
- 2) Please use the PCS 7 AS configurator, since different versions of the PCS 7 AS 410-5H are available; e. g., 24V DC or 110/230V AC.
- 3) The number of TAGs can be increased by means of cumulative TAG licenses.
- 4) Optional for FOUNDATION Fieldbus communication.
- 5) The following applies to each Standard CPU/CPU PN: If you use the PROFIBUS DP interface of the CPU for data record routing, you must configure this CPU in the HW config with firmware V5.1 or higher. If this is not the case, it needs a CP443-5 Ext PROFIBUS communications module to use PDM data record routing.
- 6) The number of PDM client licenses can be increased up to 30 in total.

12.6 SIMATIC PDM and non-SIMATIC S7 master

This configuration is a PC with SIMATIC PDM (stand-alone) connected to a PROFIBUS or PROFINET field device segment of a non-SIMATIC S7 master or S7 controller (without data set routing functionality).

PROFIBUS DP is connected to PDM via a gateway (IE/PB-Link), while PROFINET networks are connected to PDM via the service bridge and therefore remain logically separated from each other.

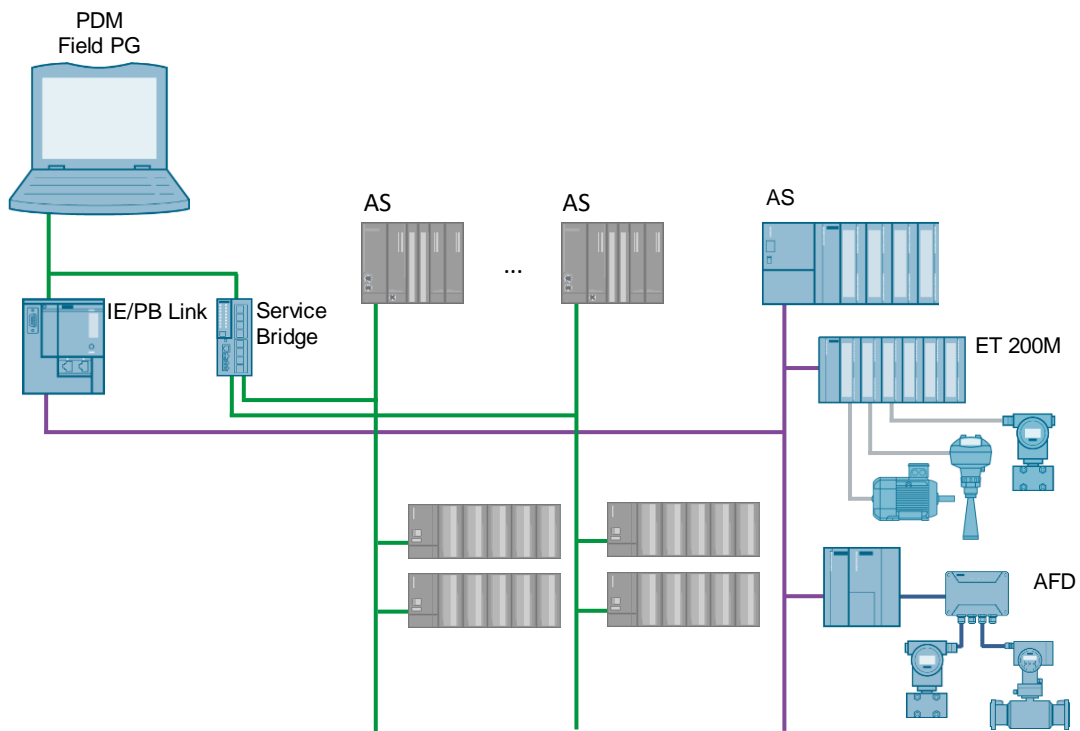

Bill of materials

Required	Optional	Article number	Product description	Note
PDM (Option 1)				
1		6ES7658-3AB68-0YA5	SIMATIC PDM BASIC V9.1 INCL. 4 TAGS	2)
	1	6ES7658-3NX68-2YB5	SIMATIC PDM EXTENDED V9.1	
PDM (Option 2)				
	1	6ES7658-3JD68-0YA5	SIMATIC PDM Service V9.1 INCL. 54 TAGS	2)
	1	6ES7658-3NX68-2YB5	SIMATIC PDM EXTENDED V9.1	
PDM (Option 3)				
1		6ES7658-3TX68-0YA5	SIMATIC PDM stand-alone server V9.1 PRODUCT PACKAGE FOR SERVICE AND DEVICE MANAGEMENT IN PLANT SECTIONS WITH - SIMATIC PDM BASIC INCL. 4 TAGS - SIMATIC PDM EXTENDED - SIMATIC PDM SERVER - 2 X SIMATIC PDM 1 CLIENT (100 TAGS)	2)
Further options for PDM optiones 1 and 2				
	1	6ES7658-3TX68-2YB5	SIMATIC PDM SERVER V9.1	
	1	6ES7658-3UA00-2YB5	SIMATIC PDM 1 CLIENT	3)
PLANT BUS				
1		6GK1411-5AB00	IE/PB-LINK PN IO	1)
1		6GK5208-0BA00-2AC2	SCALANCE XC208 MANAGEABLE LAYER 2 IE SWITCH; 8X 10/100 MBIT/S RJ45 PORTS; 1X CONSOLE PORT; DIAGNOSTIC LED; REDUNDANT POWER SUPPLY	1) 4)
		24 V DC power supply	Redundant power supply	Chapter 17.2

Note

- 1) The IE/PB module and XC switch require a 24 V DC power supply.
- 2) The number of PDM TAGs can be increased by means of cumulative TAG licenses.
- 3) The total number of PDM client licenses can be increased up to 30.
- 4) SCALANCE XC208 is configured as a service bridge. For configuration file see article "Service Bridge – Setting-up and Configuration":
<https://support.industry.siemens.com/cs/ww/en/view/109747975>

12.7 SIMATIC PDM Stand-alone server

With the SIMATIC PDM Stand-alone server product package, you can establish central service and parameter assignment stations that operate according to the client / server principle. These can be set up on an independent system, an engineering system or on the SIMATIC PCS 7 Maintenance Station.

When used on the Maintenance Station, the device parameters can be accessed from any SIMATIC PCS 7 Maintenance Station client to selected field devices via the PDM parameterization interface.

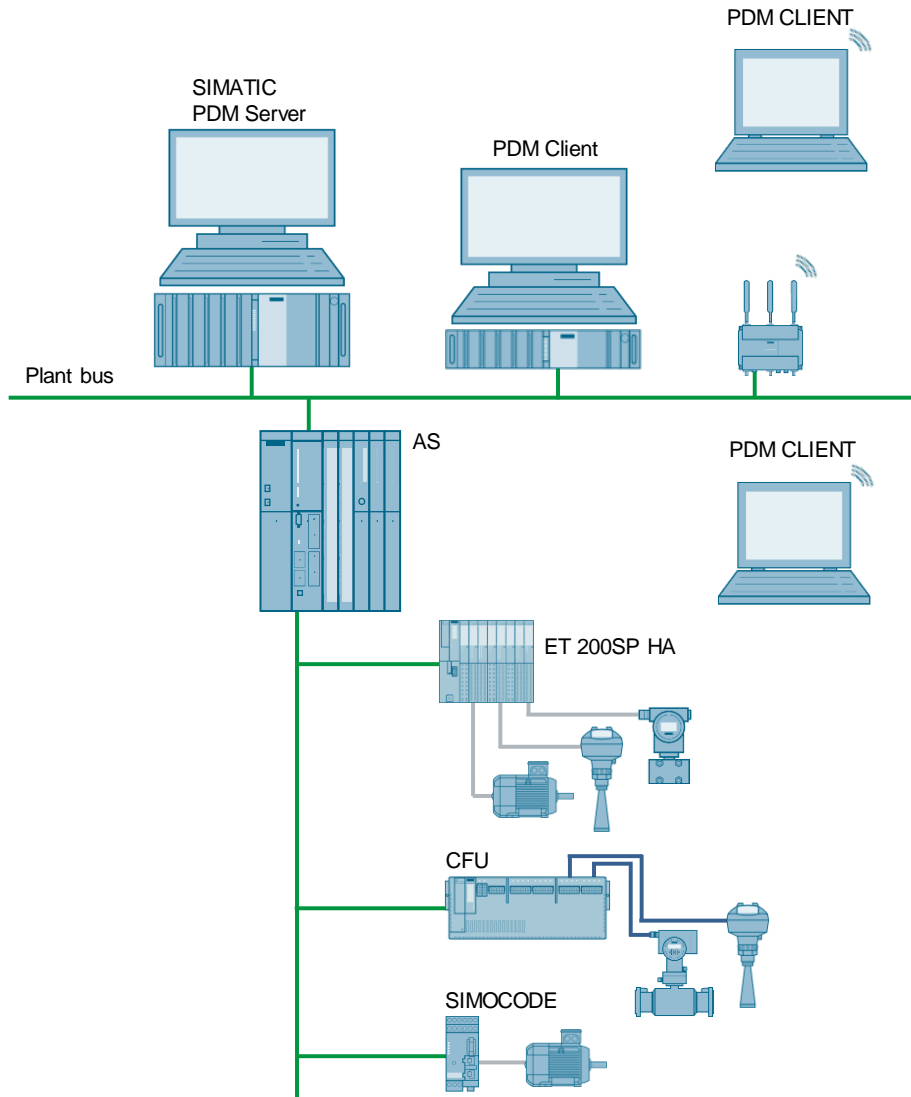

Bill of materials

Required	Optional	Article number	Product description	Note
PDM Server				
1		6ES7658-3TX68-0YA5	SIMATIC PDM stand-alone server V9.1 PRODUCT PACKAGE FOR SERVICE AND DEVICE MANAGEMENT IN PLANT SECTIONS WITH - SIMATIC PDM BASIC INCL. 4 TAGS - SIMATIC PDM EXTENDED - SIMATIC PDM SERVER - 2 X SIMATIC PDM 1 CLIENT (100 TAGS)	1)
1		6ES7658-3CX68-2YB5	SOFTWARE SIMATIC PDM ROUTING V9.1	
PDM Client				
3		6ES7658-3UA00-2YB5	SIMATIC PDM 1 CLIENT	2)
Automation system				
2		6ES7654-6CN03-3BF0	SIMATIC PCS 7 SINGLE AS, CPU 410-5H, 1X DP- MODULE, 2x PROFINET-IO, SYSTEM EXPANSION CARD 1000 PO, AS RT PO 100, CP443-1IE, UR2 ALU RACK, 1 X UC 120/230V 10A POWER SUPPLY	3) 4)
		24 V DC power supply	Redundant power supply	Chapter 17.2

Note

Laptops that are used as PDM clients are not listed. Wireless LAN that is used for laptop connection is not listed.

- 1) The number of PDM TAGs can be increased by means of cumulative TAG licenses.
- 2) The total number of PDM client licenses can be increased up to 30.
- 3) Please use the PCS 7 AS configurator, since different versions of the PCS 7 AS 410-5H are available; e. g., 24V DC or 110/230V AC.
- 4) The following applies to each Standard CPU/CPU PN:
If you use the PROFIBUS DP interface of the CPU for data record routing, you must configure this CPU in the HW config with firmware V5.1 or higher.
If this is not the case, it needs a CP443-5 Ext PROFIBUS communications module to use PDM data record routing.

13 Maintenance Station (Asset Management)

The Maintenance Station implements Plant Asset Management (according to NAMUR NE 129) in a PCS 7 multi-project. This means a system for maintaining the value of process plants by using information about the condition of all plant components (assets).

For this purpose, the Maintenance Station provides you with comprehensive diagnostic and maintenance information at all times. It is fully integrated in the operator system and contains all plant information.

The diagnostics screens that are structured according to the process cell hierarchy with the operating states of the SIMATIC PCS 7 components can be displayed on the SIMATIC PCS 7 Maintenance Station and also on the OS clients. More detailed diagnostic information that has also been determined by SIMATIC PDM is displayed in the faceplates of these stations. However, enhanced online diagnostic functions in conjunction with HW Config can only be accessed via a PCS 7 Maintenance Station on the ES.

Versions

The Maintenance Station is available in the following three versions:

1. SIMATIC PCS 7 Maintenance Station Basis (integrated in the PCS 7 project) License-free version with functional limitations
2. SIMATIC PCS 7 Maintenance Station Standard (integrated in the PCS 7 project) Licensed version with all functions
3. SIMATIC PDM Maintenance Station 2.0 (stand-alone project) Separate station based on bundle installation (Microbox PC). In the following referred to as PDM Maintenance Station

The possible configurations for the two variants of the PCS 7 Maintenance Station are described in the chapters [13.1](#) to [13.6](#)

The configuration of the PDM Maintenance Station is described in chapter [13.6](#)

Starter system

The SIMATIC PCS 7 BOX RTX system supports the full asset management functionality of the integrated automation system, the PC station and all connected field devices.

Single user station

The ES, OS and asset management functions are connected to the single user station via the Ethernet system bus. Asset Management provides diagnostic and maintenance data of the automation system, PC station, active networking components and all of the connected field devices.

Client / server (single / redundant)

Like the PCS 7-OS, the Maintenance Station can be used in a decentralized client / server structure in SIMATIC PCS 7.

The maintenance server is based on an OS server. It can be implemented as a combined OS / MS server (on an existing OS server) or as a separate MS server.

The Maintenance Station uses the standard display and messages from the PCS 7-OS that refer to the diagnosis area.

The OS clients that are logged on to the MS server can access maintenance images in PCS 7 just like standard process images.

These maintenance images include additional information for detailed diagnostics and troubleshooting of intelligent field devices.

Furthermore, SIMATIC PDM can be called from any of these MS clients.

Maintenance station in flat hierarchies

The PCS 7 Maintenance Station can also be used in flat hierarchies.

SIMATIC PDM Maintenance Station

The SIMATIC PDM MS is a pre-configured single user system as IPC Mircobox 427E. It is designed for stand-alone use and independent of the automation solution used.

In terms of presentation and function, the SIMATIC PDM MS is designed in the same way as a SIMATIC PCS 7 Maintenance Station. All operating and monitoring functions are carried out locally on this PC station.

Primarily, SIMATIC PDM MS is designed to be used for diagnostics, field device management, acquiring and transferring the parameterization, diagnostic and status data of field devices.

Note

There is exactly one MS server for each project (single or redundant).
Alternatively, several PDM Maintenance Stations can be used in one project.

13.1 PCS 7 Maintenance Station in the starter system

This configuration is a SIMATIC PCS 7 BOX RTX system with ES, OS, AS, and Maintenance Station.



Bill of materials

Required	Optional	Article number	Product description	Note
Engineering Station, Operator Station and Automation System				
1		6ES7650-4BB10-3RA0	PCS 7 V9.0 BOX RTX ES/OS SYSTEM (WINAC RTX 2010), WINDOWS 7 ULTIMATE 32BIT, PROFINET ONBOARD, PCS 7 V9.0 PREINSTALLED	1) 5)
1		6ES7658-7GB58-0YB0	SOFTWARE SIMATIC PCS 7 MAINTENANCE STATION RUNTIME BASIC PACKAGE V9.0 (incl. SNMP-OPC	2)

Required	Optional	Article number	Product description	Note
			server license and 100 Asset TAGs)	
	1	6ES7652-0XD58-2YB5	SOFTWARE SIMATIC PCS 7 SFC VISUALIZATION V9.0	
	1	6ES7658-1CX58-2YA5	SOFTWARE SIMATIC PCS 7 VERSION CROSS MANAGER V9.0	
	1	6ES7658-1DX58-2YB5	SOFTWARE SIMATIC PCS 7 IMPORT EXPORT ASSISTANT V9.0	
	1	6ES7658-1FX58-2YA5	SOFTWARE SIMATIC PCS 7 VERSION TRAIL V9.0	
	1	6ES7658-3LD68-0YA5	SOFTWARE SIMATIC PDM PCS 7 V9.1 (100 TAGs)	3)
1		6ES7658-7GX58-0YB5	SIMATIC PCS 7 MAINTENANCE STATION ENGINEERING V9.0	
	1	6ES7658-3QX68-2YB5	SOFTWARE SIMATIC PDM COMMUNICATION FOUNDATION FIELDBUS V9.1	4)
		24 V DC power supply	Buffered power supply	Chapter 17.5

Note

PDM is an optional enhancement for Asset Management.

PDM is necessary when operating intelligent field devices or when using the AssetMon module (for the integration of non-intelligent devices in Asset Management).

Note

1) Please use the PCS 7 BOX configurator, as the PCS 7 BOX is available in different versions, e. g. 24V DC or 110/230V AC.

2) The number of Asset TAGs can be increased by means of cumulative Asset TAG licenses.

3) The number of PDM TAGs can be increased by means of cumulative TAG licenses.

4) Optional for FOUNDATION Fieldbus communication.

5) Necessary if a redundant terminal bus is selected.

13.2 PCS 7 maintenance station in single user system

This configuration is a system in which the ES, OS, and Maintenance Station are used on one PC as a single user system.

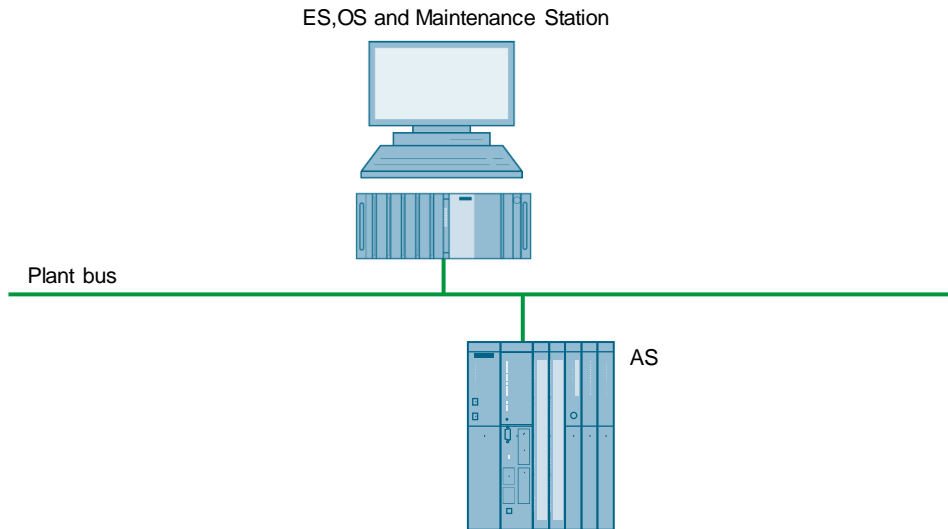

Bill of materials

Required	Optional	Article number	Product description	Note
Engineering Station, PDM and Operator Station				
1		6ES7660-6DA10-3BA0	SIMATIC PCS 7 INDUSTRIAL WORKSTATION IPC847D, CORE I5, ES/OS SINGLESTATION, 500 GB HD SATA, 8GB DDR3, BCE, PCS 7 V9.0, WINDOWS 10 ENTERPRISE 2015 LTSC 64BIT	
1		6ES7651-5AA58-0YA0	SIMATIC PCS 7, SOFTWARE, ES SINGLE STATION V9.0 (AS/OS: 250 POs)	1)
	1	6ES7652-0XD58-2YB5	SOFTWARE SIMATIC PCS 7 SFC VISUALIZATION V9.0	
	1	6ES7658-1CX58-2YA5	SOFTWARE SIMATIC PCS 7 VERSION CROSS MANAGER V9.0	
	1	6ES7658-1DX58-2YB5	SOFTWARE SIMATIC PCS 7 IMPORT EXPORT ASSISTANT V9.0	
	1	6ES7658-1FX58-2YA5	SOFTWARE SIMATIC PCS 7 VERSION TRAIL V9.0	
	1	6ES7658-3LD68-0YA5	SOFTWARE SIMATIC PDM PCS 7 V9.1 (100 TAGs)	3)
1		6ES7658-7GB58-0YB0	SOFTWARE SIMATIC PCS 7 MAINTENANCE STATION RUNTIME BASIC PACKAGE V9.0 (incl. SNMP-OPC server license and 100 Asset TAGs)	4)
1		6ES7658-7GX58-0YB5	SIMATIC PCS 7 MAINTENANCE STATION ENGINEERING V9.0	
	1	6ES7658-3QX68-2YB5	SOFTWARE SIMATIC PDM COMMUNICATION FOUNDATION FIELDBUS V9.1	5)

Required	Optional	Article number	Product description	Note
Automation system				
1		6ES7654-6CL03-3BF0	SIMATIC PCS 7 SINGLE AS, CPU 410-5H, SYSTEM EXPANSIONS CARD 500 PO, AS RT PO 100, CP443-1IE, UR2 ALU RACK, UC 120/230V 10A POWER SUPPLY	²⁾
		24 V DC power supply	Redundant power supply	Chapter 17.2

Note

- ¹⁾ The number of POs can be increased later by means of extra volume licenses.
- ²⁾ Please use the PCS 7 AS configurator, since different versions of the PCS 7 AS 410-5H are available; e. g., 24V DC or 110/230V AC.
- ³⁾ The number of PDM TAGs can be increased by means of cumulative TAG licenses.
- ⁴⁾ The number of Asset TAGs can be increased by means of cumulative Asset TAG licenses.
- ⁵⁾ Optional for FOUNDATION Fieldbus communication.

Sample calculation with asset management single user station

The following is a sample calculation with asset management tags, process objects and PDM tags for a given single user configuration.

The single user configuration consists of the following:

- an ES/OS/MS single user
- 200 PROFIBUS PA sensors and actuators
- 100 HART analog sensors and actuators
- 32 FOUNDATION Fieldbus H1 sensors and actuators
- 8 ET 200M IO racks, total of 50 IO modules
- 80 PROFIBUS DP Slaves with EDDL Configuration
- 25 PROFIBUS DP Slaves without EDDL configuration
- 1 AS 410-5H
- 5 PROFIBUS DP and PA networking segments
- 120 process devices with asset monitoring functionality

The components below are needed for the configuration mentioned above:

Item	Counter value	Asset Management TAGs	Process objects	PDM TAGs
Computer	1	1	0	0
PROFIBUS PA	200	200	0	200
HART	100	100	0	100
FOUNDATION field bus H1	32	32	0	32
ET 200M IM bus interface	8	8	0	0
ET 200M modules	50	0	0	0
PROFIBUS DP slaves - EDDL	80	80	0	80
PROFIBUS DP slaves - without EDDL	25	25	0	0
Automation system	1	1	0	0
Network devices (e. g. switches)	7	0	0	0
Process devices	120	120	120	120
Total		567	120	532

Bill of materials

Required	Optional	Article number	Product description	Note
Engineering Station, PDM, and Operator Station				
1		6ES7660-6DA10-3BA0	SIMATIC PCS 7 INDUSTRIAL WORKSTATION IPC847D, CORE I5, ES/OS SINGLESTATION, 500 GB HD SATA, 8GB DDR3, BCE, PCS 7 V9.0, WINDOWS 10 ENTERPRISE 2015 LTSB 64BIT	
1		6ES7651-5AA58-0YA0	SIMATIC PCS 7, SOFTWARE, ES SINGLE STATION V9.0 (AS/OS: 250 POs)	1)
	1	6ES7652-0XD58-2YB5	SOFTWARE SIMATIC PCS 7 SFC VISUALIZATION V9.0	
	1	6ES7658-1CX58-2YA5	SOFTWARE SIMATIC PCS 7 VERSION CROSS MANAGER V9.0	
	1	6ES7658-1DX58-2YB5	SOFTWARE SIMATIC PCS 7 IMPORT EXPORT ASSISTANT V9.0	
	1	6ES7658-1FX58-2YA5	SOFTWARE SIMATIC PCS 7 VERSION TRAIL V9.0	
1		6ES7658-3LD68-0YA5	SOFTWARE SIMATIC PDM PCS 7 V9.1 (100 TAGs)	3)
4		6ES7658-3XC00-2YB5	SIMATIC PDM 10 TAGs	3)
4		6ES7658-3XD00-2YB5	SIMATIC PDM 100 TAGs	3)
1		6ES7658-3QX68-2YB5	SOFTWARE SIMATIC PDM COMMUNICATION FOUNDATION FIELDBUS V9.1	5)
1		6ES7658-7GB58-0YB0	SOFTWARE SIMATIC PCS 7 MAINTENANCE STATION RUNTIME BASIC PACKAGE V9.0 (incl. SNMP-OPC server license and 100 Asset TAGs)	4)
1		6ES7658-7GX58-0YB5	SIMATIC PCS 7 MAINTENANCE STATION ENGINEERING V9.0	
5		6ES7658-7GB00-2YB0	SIMATIC PCS 7 MAINTENANCE STATION RUNTIME ASSET TAGS (100 TAGs)	4)
1		6ES7654-6CL03-3BF0	SIMATIC PCS 7 SINGLE AS, CPU 410-5H, SYSTEM EXPANSIONS CARD 500 PO, AS RT PO 100, CP443-1IE, UR2 ALU RACK, UC 120/230V 10A POWER SUPPLY	2)
		24 V DC power supply	Redundant power supply	Chapter 17.2

Note

- 1) The number of POs can be increased later by means of extra volume licenses.
- 2) Please use the PCS 7 AS configurator, since different versions of the PCS 7 AS 410-5H are available; e. g., 24V DC or 110/230V AC.
- 3) The number of PDM TAGs can be increased by means of cumulative TAG licenses in steps of 10/100/1000.
- 4) The number of Asset TAGs can be increased by means of cumulative Asset TAG licenses.
- 5) Optional for FOUNDATION Fieldbus communication.

13.3 PCS 7 Maintenance Station in a multi-user system with MS / OS clients and combined MS / OS server

In this configuration, the system has one OS server and three OS clients. Additionally, the MS server is configured on the OS server. Depending on the assignment and access rights, each of the OS clients can be used as a Maintenance Station (MS client).

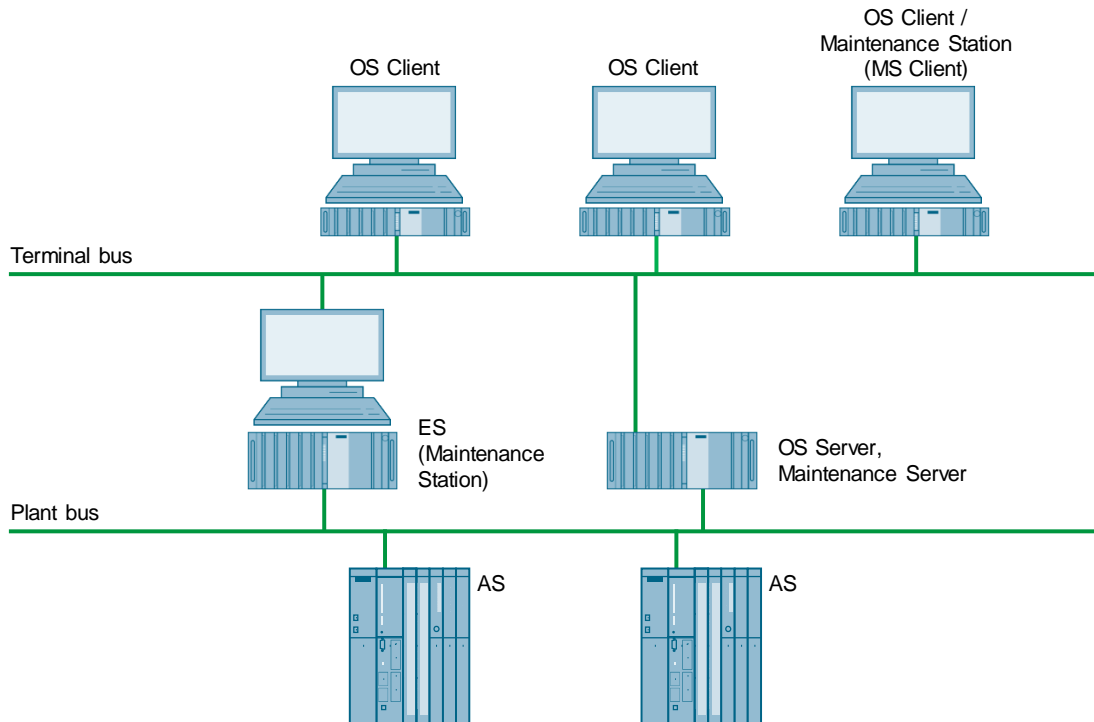

© Siemens AG 2019. All rights reserved

Bill of materials

Required	Optional	Article number	Product description	Note
Engineering Station				
1		6ES7660-6DA10-3BA0	SIMATIC PCS 7 INDUSTRIAL WORKSTATION IPC847D, CORE I5, ES/OS SINGLESTATION, 500 GB HD SATA, 8GB DDR3, BCE, PCS 7 V9.0, WINDOWS 10 ENTERPRISE 2015 LTSC 64BIT	
1		6ES7658-5AX58-0YA5	SOFTWARE SIMATIC PCS 7 AS/OS ENGINEERING V9.0	
	1	6ES7652-0XD58-2YB5	SOFTWARE SIMATIC PCS 7 SFC VISUALIZATION V9.0	
	1	6ES7658-1CX58-2YA5	SOFTWARE SIMATIC PCS 7 VERSION CROSS MANAGER V9.0	
	1	6ES7658-1FX58-2YA5	SOFTWARE SIMATIC PCS 7 VERSION TRAIL V9.0	
	1	6ES7658-1DX58-2YB5	SOFTWARE SIMATIC PCS 7 IMPORT EXPORT	

Required	Optional	Article number	Product description	Note
			ASSISTANT V9.0	
1		6ES7658-3TD68-0YA5	SOFTWARE SIMATIC PDM PCS 7 SERVER V9.1 (100 TAGs)	3)
	1	6ES7658-3QX68-2YB5	SOFTWARE SIMATIC PDM COMMUNICATION FOUNDATION FIELDBUS V9.1	5)
1		6ES7658-7GX58-0YB5	SIMATIC PCS 7 MAINTENANCE STATION ENGINEERING V9.0	
1		6ES7658-2CX58-0YB5	SOFTWARE SIMATIC PCS 7 OS-CLIENT V9.0	
OS server, Maintenance server				
1		6ES7660-6EC10-3EA0	SIMATIC PCS 7 INDUSTRIAL WORKSTATION IPC847D, CORE I5, OS-SERVER, RAID1 (2 X 1 TB HDD SATA, DATA MIRRORING), 8GB DDR3, BCE, PCS 7 V9.0, WIN SERVER 2012 R2 STANDARD EDITION INCL. 5 CLIENT 64BIT	
1		6ES7658-2BA58-0YA0	SOFTWARE SIMATIC PCS 7 OS-SERVER V9.0 (PO 100)	1)
1		6ES7658-7GB58-0YB0	SOFTWARE SIMATIC PCS 7 MAINTENANCE STATION RUNTIME BASIC PACKAGE V9.0 (incl. SNMP-OPC server license and 100 Asset TAGs)	4)
OS client				
3		6ES7660-5FA08-3BA0	SIMATIC PCS 7 INDUSTRIAL WORKSTATION IPC647D, CORE I5, OS-CLIENT, 500 GB HD SATA, 4GB DDR3, PCS 7 V9.0, WINDOWS 10 ENTERPRISE 2015 LTSB 64BIT	
3		6ES7658-2CX58-0YB5	SOFTWARE SIMATIC PCS 7 OS-CLIENT V9.0	
	3	6ES7652-0XD58-2YB5	SOFTWARE SIMATIC PCS 7 SFC VISUALIZATION V9.0	
Automation system				
2		6ES7654-6CN03-3BF0	SIMATIC PCS 7 SINGLE AS, CPU 410-5H, 1X DP-MODULE, 2x PROFINET-IO, SYSTEM EXPANSION CARD 1000 PO, AS RT PO 100, CP443-1IE, UR2 ALU RACK, 1 X UC 120/230V 10A POWER SUPPLY	2)
		24 V DC power supply	Redundant power supply	Chapter 17.2

Note

- 1) The number of POs can be increased later by means of extra volume licenses.
- 2) Please use the PCS 7 AS configurator, since different versions of the PCS 7 AS 410-5H are available; e. g., 24V DC or 110/230V AC.
- 3) The number of PDM TAGs can be increased by means of cumulative TAG licenses.
- 4) The number of Asset TAGs can be increased by means of cumulative Asset TAG licenses.
- 5) Optional for FOUNDATION Fieldbus communication.

Sample calculation for the Asset Management client / server

The following is a sample calculation for the number of asset management tags, process objects and PDM tags for a given client / server configuration.

The client / server configuration includes:

- an ES/OS/MS client computer
- one OS server
- three OS clients
- 300 PROFIBUS PA sensors and actuators
- 180 HART analog sensors and actuators
- 80 FOUNDATION Fieldbus H1 sensors and actuators
- 20 ET 200M IO racks, total of 135 IO modules
- 160 PROFIBUS DP Slaves with EDDL Configuration
- 60 PROFIBUS DP slaves without EDDL configuration
- 2 AS 410-5Hs
- 8 PROFIBUS DP and PA networking segments
- 240 process devices with asset monitoring functionality

The following components are needed for the configuration:

Item	Counter value	Asset Management TAGs	Process objects	PDM TAGs
Computer	5	5	0	0
PROFIBUS PA	300	300	0	300
HART	180	180	0	180
FOUNDATION Fieldbus H1	80	80	0	80
ET 200M IM bus interface	20	20	0	0
ET 200M modules	135	0	0	0
PROFIBUS DP slaves - EDDL	160	160	0	160
PROFIBUS DP slaves - without EDDL	60	60	0	0
Automation system	2	2	0	0
Network devices (e. g. switches)	10	0	0	0
Process devices	240	240	240	240
Total				
		1047	240	960

Bill of materials

Required	Optional	Article number	Product description	Note
Engineering Station				
1		6ES7660-6DA10-3BA0	SIMATIC PCS 7 INDUSTRIAL WORKSTATION IPC847D, CORE I5, ES/OS SINGLESTATION, 500 GB HD SATA, 8GB DDR3, BCE, PCS 7 V9.0, WINDOWS 10 ENTERPRISE 2015 LTSB 64BIT	
1		6ES7658-5AX58-0YA5	SOFTWARE SIMATIC PCS 7 AS/OS ENGINEERING V9.0	
	1	6ES7652-0XD58-2YB5	SOFTWARE SIMATIC PCS 7 SFC VISUALIZATION V9.0	
	1	6ES7658-1CX58-2YA5	SOFTWARE SIMATIC PCS 7 VERSION CROSS MANAGER V9.0	
	1	6ES7658-1FX58-2YA5	SOFTWARE SIMATIC PCS 7 VERSION TRAIL V9.0	
	1	6ES7658-1DX58-2YB5	SOFTWARE SIMATIC PCS 7 IMPORT EXPORT ASSISTANT V9.0	
1		6ES7658-3TD68-0YA5	SOFTWARE SIMATIC PDM PCS 7 SERVER V9.1 (100 TAGs)	3)
8		6ES7658-3XD00-2YB5	SIMATIC PDM 100 TAGs	3)
6		6ES7658-3XC00-2YB5	SIMATIC PDM 10 TAGs	3)
1		6ES7658-3QX68-2YB5	SOFTWARE SIMATIC PDM COMMUNICATION FOUNDATION FIELDBUS V9.1	5)
1		6ES7658-7GX58-0YB5	SIMATIC PCS 7 MAINTENANCE STATION ENGINEERING V9.0	
1		6ES7658-2CX58-0YB5	SOFTWARE SIMATIC PCS 7 OS-CLIENT V9.0	
OS server, Maintenance server				
1		6ES7660-6EC10-3EA0	SIMATIC PCS 7 INDUSTRIAL WORKSTATION IPC847D, CORE I5, OS-SERVER, RAID1 (2 X 1 TB HDD SATA, DATA MIRRORING), 8GB DDR3, BCE, PCS 7 V9.0, WIN SERVER 2012 R2 STANDARD EDITION INCL. 5 CLIENT 64BIT	
1		6ES7658-2BA58-0YA0	SOFTWARE SIMATIC PCS 7 OS-SERVER V9.0 (PO 100)	1)
1		6ES7658-7GB58-0YB0	SOFTWARE SIMATIC PCS 7 MAINTENANCE STATION RUNTIME BASIC PACKAGE V9.0 (incl. SNMP-OPC server license and 100 Asset TAGs)	4)
1		6ES7658-7GC00-2YB0	SIMATIC PCS 7 MAINTENANCE STATION RUNTIME ASSET-TAGS (1000 TAGs)	4)
OS client				
3		6ES7660-5FA08-3BA0	SIMATIC PCS 7 INDUSTRIAL WORKSTATION IPC647D, CORE I5, OS-CLIENT, 500 GB HD SATA, 4GB DDR3, PCS 7 V9.0, WINDOWS 10 ENTERPRISE 2015 LTSB 64BIT	
3		6ES7658-2CX58-0YB5	SOFTWARE SIMATIC PCS 7 OS-CLIENT V9.0	
	3	6ES7652-0XD58-2YB5	SOFTWARE SIMATIC PCS 7 SFC VISUALIZATION V9.0	

Required	Optional	Article number	Product description	Note
Automation system				
2		6ES7654-6CP03-3BF0	SIMATIC PCS 7 SINGLE AS, CPU 410-5H, 1X DP-MODULE, 2x PROFINET-IO, SYSTEM EXPANSION CARD 1600 PO, AS RT PO 100, CP443-1IE, UR2 ALU RACK, 1 X UC 120/230V 10A POWER SUPPLY	2)
		24 V DC power supply	Redundant power supply	Chapter 17.2

Note

- 1) The number of POs can be increased later by means of extra volume licenses.
- 2) Please use the PCS 7 AS configurator, since different versions of the PCS 7 AS 410-5H are available; e. g., 24V DC or 110/230V AC.
- 3) The number of PDM TAGs can be increased by means of cumulative TAG licenses in steps of 10/100/1000.
- 4) The number of Asset TAGs can be increased by means of cumulative Asset TAG licenses.
- 5) Optional for FOUNDATION Fieldbus communication.

13.4 PCS 7 Maintenance Station in a multi user system with MS / OS clients and separate MS server and red. OS server

In this configuration, the system has one redundant OS server pair and three OS clients. The ES and the Maintenance Station are configured on a separate PC. The Maintenance server is also configured on a separate PC.

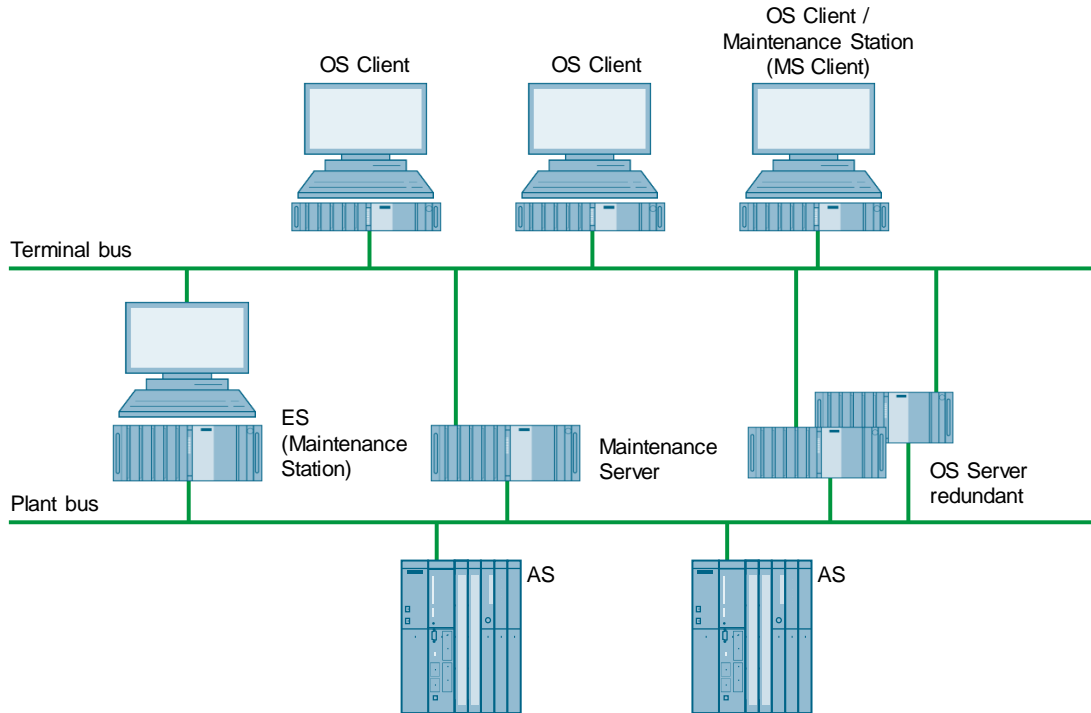

Bill of materials

Required	Optional	Article number	Product description	Note
Engineering Station				
1		6ES7660-6DA10-3BA0	SIMATIC PCS 7 INDUSTRIAL WORKSTATION IPC847D, CORE I5, ES/OS SINGLESTATION, 500 GB HD SATA, 8GB DDR3, BCE, PCS 7 V9.0, WINDOWS 10 ENTERPRISE 2015 LTSB 64BIT	
1		6ES7658-5AX58-0YA5	SOFTWARE SIMATIC PCS 7 AS/OS ENGINEERING V9.0	
	1	6ES7652-0XD58-2YB5	SOFTWARE SIMATIC PCS 7 SFC VISUALIZATION V9.0	
	1	6ES7658-1CX58-2YA5	SOFTWARE SIMATIC PCS 7 VERSION CROSS MANAGER V9.0	
	1	6ES7658-1FX58-2YA5	SOFTWARE SIMATIC PCS 7 VERSION TRAIL V9.0	
	1	6ES7658-1DX58-2YB5	SOFTWARE SIMATIC PCS 7 IMPORT EXPORT ASSISTANT V9.0	
1		6ES7658-3TD68-0YA5	SOFTWARE SIMATIC PDM PCS 7 Server V9.1 (100 TAGs)	3)
	1	6ES7658-3QX68-2YB5	SOFTWARE SIMATIC PDM COMMUNICATION FOUNDATION FIELDBUS V9.1	6)
1		6ES7658-7GX58-0YB5	SIMATIC PCS 7 MAINTENANCE STATION ENGINEERING V9.0	
1		6ES7658-2CX58-0YB5	SOFTWARE SIMATIC PCS 7 OS-CLIENT V9.0	
OS server				
2		6ES7660-6EF21-3EA0	SIMATIC PCS 7 INDUSTRIAL WORKSTATION IPC847D, CORE I5, OS-SERVER, RAID1 (2 X 1 TB HDD SATA, DATA MIRRORING), 16GB DDR3, INDUSTRIAL ETHERNET (CP1623), PCS 7 V9.0, WINDOWS SERVER 2012 R2 STANDARD EDITION, 64 BIT	
1		6ES7652-3BA58-2YA0	SOFTWARE SIMATIC PCS 7 OS-SERVER REDUNDANCY V9.0 (PO 100)	1) 5)
Maintenance server				
1		6ES7660-6EC10-3EA0	SIMATIC PCS 7 INDUSTRIAL WORKSTATION IPC847D, CORE I5, OS-SERVER, RAID1 (2 X 1 TB HDD SATA, DATA MIRRORING), 8GB DDR3, BCE, PCS 7 V9.0, WIN SERVER 2012 R2 STANDARD EDITION INCL. 5 CLIENT 64BIT	
1		6ES7658-2BA58-0YA0	SOFTWARE SIMATIC PCS 7 OS-SERVER V9.0 (PO 100)	1)
1		6ES7658-7GB58-0YB0	SOFTWARE SIMATIC PCS 7 MAINTENANCE STATION RUNTIME BASIC PACKAGE V9.0 (incl. SNMP-OPC server license and 100 Asset TAGs)	4)

Required	Optional	Article number	Product description	Note
OS client				
3		6ES7660-5FA08-3BA0	SIMATIC PCS 7 INDUSTRIAL WORKSTATION IPC647D, CORE I5, OS-CLIENT, 500 GB HD SATA, 4GB DDR3, PCS 7 V9.0, WINDOWS 10 ENTERPRISE 2015 LTSB 64BIT	
3		6ES7658-2CX58-0YB5	SOFTWARE SIMATIC PCS 7 OS-CLIENT V9.0	
	3	6ES7652-0XD58-2YB5	SOFTWARE SIMATIC PCS 7 SFC VISUALIZATION V9.0	
Automation system				
2		6ES7654-6CN03-3BF0	SIMATIC PCS 7 SINGLE AS, CPU 410-5H, 1X DP-MODULE, 2x PROFINET-IO, SYSTEM EXPANSION CARD 1000 PO, AS RT PO 100, CP443-1IE, UR2 ALU RACK, 1 X UC 120/230V 10A POWER SUPPLY	2)
		24 V DC power supply	Redundant power supply	Chapter 17.2

Note

- 1) The number of POs can be increased later by means of extra volume licenses.
- 2) Please use the PCS 7 AS configurator, since different versions of the PCS 7 AS 410-5H are available; e. g., 24V DC or 110/230V AC.
- 3) The number of TAGs can be increased by means of cumulative TAG licenses.
- 4) Note for asset runtime:
The number of asset TAGs can be increased by means of cumulative asset TAG licenses. An increase of the asset TAGs requires an increase of AS and OS RT process objects for the maintenance server.
- 5) The redundant OS server is supplied with an RS-232 serial connection cable. If there is a long distance between the redundant systems, you can establish an Ethernet connection as an alternative. This requires additional Ethernet network interface cards in the systems.
- 6) Optional for FOUNDATION Fieldbus communicatio

13.5 PCS 7 Maintenance Station in a multi user system with MS / OS clients and separate redundant MS server pair and OS server pair

In this configuration, the system has one redundant OS server pair and three OS clients. The ES and the Maintenance Station are configured on a separate PC. The maintenance server is configured on a redundant basis and as a separate system.

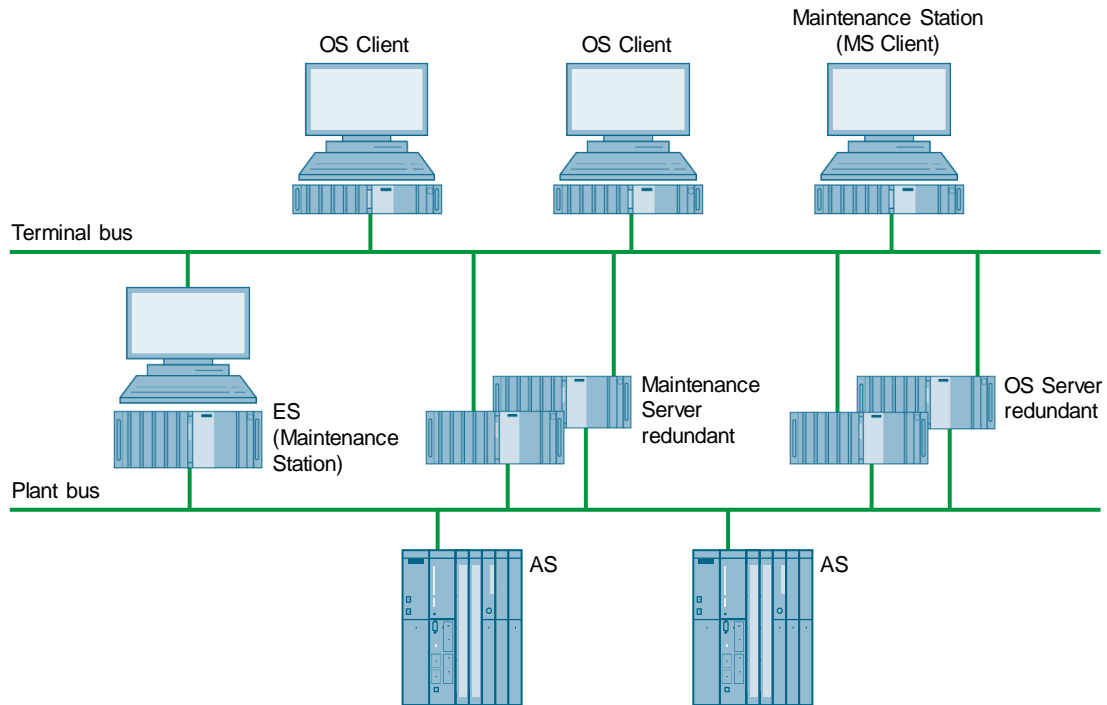

Bill of materials

Required	Optional	Article number	Product description	Note
Engineering Station				
1		6ES7660-6DA10-3BA0	SIMATIC PCS 7 INDUSTRIAL WORKSTATION IPC847D, CORE I5, ES/OS SINGLESTATION, 500 GB HD SATA, 8GB DDR3, BCE, PCS 7 V9.0, WINDOWS 10 ENTERPRISE 2015 LTSB 64BIT	
1		6ES7658-5AX58-0YA5	SOFTWARE SIMATIC PCS 7 AS/OS ENGINEERING V9.0	
	1	6ES7652-0XD58-2YB5	SOFTWARE SIMATIC PCS 7 SFC VISUALIZATION V9.0	
	1	6ES7658-1CX58-2YA5	SOFTWARE SIMATIC PCS 7 VERSION CROSS MANAGER V9.0	
	1	6ES7658-1FX58-2YA5	SOFTWARE SIMATIC PCS 7 VERSION TRAIL V9.0	
	1	6ES7658-1DX58-2YB5	SOFTWARE SIMATIC PCS 7 IMPORT EXPORT ASSISTANT V9.0	
1		6ES7658-3TD68-0YA5	SOFTWARE SIMATIC PDM PCS 7 SERVER V9.1 (100 TAGs)	3)
	1	6ES7658-3QX68-2YB5	SOFTWARE SIMATIC PDM COMMUNICATION FOUNDATION FIELDBUS V9.1	6)
1		6ES7658-7GX58-0YB5	SIMATIC PCS 7 MAINTENANCE STATION ENGINEERING V9.0	
1		6ES7658-2CX58-0YB5	SOFTWARE SIMATIC PCS 7 OS-CLIENT V9.0	
OS server				
2		6ES7660-6EF21-3EA0	SIMATIC PCS 7 INDUSTRIAL WORKSTATION IPC847D, CORE I5, OS-SERVER, RAID1 (2 X 1 TB HDD SATA, DATA MIRRORING), 16GB DDR3, INDUSTRIAL ETHERNET (CP1623), PCS 7 V9.0, WINDOWS SERVER 2012 R2 STANDARD EDITION, 64 BIT	
1		6ES7652-3BA58-2YA0	SOFTWARE SIMATIC PCS 7 OS-SERVER REDUNDANCY V9.0 (PO 100)	1) 5)
OS server, Maintenance server				
2		6ES7660-6EF21-3EA0	SIMATIC PCS 7 INDUSTRIAL WORKSTATION IPC847D, CORE I5, OS-SERVER, RAID1 (2 X 1 TB HDD SATA, DATA MIRRORING), 16GB DDR3, INDUSTRIAL ETHERNET (CP1623), PCS 7 V9.0, WINDOWS SERVER 2012 R2 STANDARD EDITION, 64 BIT	
1		6ES7652-3BA58-2YA0	SOFTWARE SIMATIC PCS 7 OS-SERVER REDUNDANCY V9.0 (PO 100)	1) 5)
2		6ES7658-7GB58-0YB0	SOFTWARE SIMATIC PCS 7 MAINTENANCE STATION RUNTIME BASIC PACKAGE V9.0 (incl. SNMP-OPC server license and 100 Asset TAGs)	4)

Required	Optional	Article number	Product description	Note
OS client				
3		6ES7660-5FA08-3BA0	SIMATIC PCS 7 INDUSTRIAL WORKSTATION IPC647D, CORE I5, OS-CLIENT, 500 GB HD SATA, 4GB DDR3, PCS 7 V9.0, WINDOWS 10 ENTERPRISE 2015 LTSB 64BIT	
3		6ES7658-2CX58-0YB5	SOFTWARE SIMATIC PCS 7 OS-CLIENT V9.0	
	3	6ES7652-0XD58-2YB5	SOFTWARE SIMATIC PCS 7 SFC VISUALIZATION V9.0	
Automation system				
2		6ES7654-6CN03-3BF0	SIMATIC PCS 7 SINGLE AS, CPU 410-5H, 1X DP-MODULE, 2x PROFINET-IO, SYSTEM EXPANSION CARD 1000 PO, AS RT PO 100, CP443-1IE, UR2 ALU RACK, 1 X UC 120/230V 10A POWER SUPPLY	2)
		24 V DC power supply	Redundant power supply	Chapter 17.2

Note

- 1) The number of POs can be increased later by means of extra volume licenses.
- 2) Please use the PCS 7 AS configurator, since different versions of the PCS 7 AS 410-5H are available; e. g., 24V DC or 110/230V AC.
- 3) The number of PDM TAGs can be increased by means of cumulative TAG licenses.
- 4) Note for asset runtime:
 - The number of Asset TAGs can be increased by means of cumulative Asset TAG licenses.
 - An increase of the asset TAGs requires an increase of AS and OS RT process objects for the maintenance server.
- 5) The redundant OS server is supplied with an RS-232 serial connection cable. If there is a long distance between the redundant systems, you can establish an Ethernet connection as an alternative. This requires additional Ethernet network interface cards in the systems.

Sample calculation for a redundant asset management client / server system

The following is a sample calculation for the number of asset management tags, process objects and PDM tags for a specified redundant client / server configuration.

The redundant client / server configuration includes:

- one ES/OS/MS client PC
- one OS / MS server pair
- one OS server pair
- three OS clients
- 300 PROFIBUS PA sensors and actuators
- 180 HART analog sensors and actuators
- 80 FOUNDATION Fieldbus H1 sensors and actuators
- 20 ET 200M IO racks, total of 135 IO modules
- 160 PROFIBUS DP Slaves with EDDL Configuration
- 60 PROFIBUS DP slaves without EDDL configuration
- 2 AS 410-5Hs
- 8 PROFIBUS DP and PA networking segments
- 240 process devices with asset monitoring functionality

The following components are needed for the configuration:

Item	Counter value	Asset Management TAGs	Process objects	PDM TAGs
Computer	8	8	0	0
PROFIBUS PA	300	300	0	300
HART	180	180	0	180
FOUNDATION Fieldbus H1	80	80	0	80
ET 200M IM bus interface	20	20	0	0
ET 200M modules	135	0	0	0
PROFIBUS DP slaves - EDDL	160	160	0	160
PROFIBUS DP slaves - without EDDL	60	60	0	0
Automation system	2	2	0	0
Network devices (e. g. switches)	10	0	0	0
Process devices	240	240	240	240
Total		1050	240	960

Bill of materials

Required	Optional	Article number	Product description	Note
Engineering Station				
1		6ES7660-6DA10-3BA0	SIMATIC PCS 7 INDUSTRIAL WORKSTATION IPC847D, CORE I5, ES/OS SINGLESTATION, 500 GB HD SATA, 8GB DDR3, BCE, PCS 7 V9.0, WINDOWS 10 ENTERPRISE 2015 LTSB 64BIT	
1		6ES7658-5AX58-0YA5	SOFTWARE SIMATIC PCS 7 AS/OS ENGINEERING V9.0	
	1	6ES7652-0XD58-2YB5	SOFTWARE SIMATIC PCS 7 SFC VISUALIZATION V9.0	
	1	6ES7658-1CX58-2YA5	SOFTWARE SIMATIC PCS 7 VERSION CROSS MANAGER V9.0	
	1	6ES7658-1FX58-2YA5	SOFTWARE SIMATIC PCS 7 VERSION TRAIL V9.0	
	1	6ES7658-1DX58-2YB5	SOFTWARE SIMATIC PCS 7 IMPORT EXPORT ASSISTANT V9.0	
1		6ES7658-3TD68-0YA5	SOFTWARE SIMATIC PDM PCS 7 SERVER V9.1 (100 TAGs)	
8		6ES7658-3XD00-2YB5	SIMATIC PDM 100 TAGs	
6		6ES7658-3XC00-2YB5	SIMATIC PDM 10 TAGs	
1		6ES7658-3QX68-2YB5	SOFTWARE SIMATIC PDM COMMUNICATION FOUNDATION FIELDBUS V9.1	
1		6ES7658-7GX58-0YB5	SIMATIC PCS 7 MAINTENANCE STATION ENGINEERING V9.0	
1		6ES7658-2CX58-0YB5	SOFTWARE SIMATIC PCS 7 OS-CLIENT V9.0	
OS server				
2		6ES7660-6EF21-3EA0	SIMATIC PCS 7 INDUSTRIAL WORKSTATION IPC847D, CORE I5, OS-SERVER, RAID1 (2 X 1 TB HDD SATA, DATA MIRRORING), 16GB DDR3, INDUSTRIAL ETHERNET (CP1623), PCS 7 V9.0, WINDOWS SERVER 2012 R2 STANDARD EDITION, 64 BIT	
1		6ES7652-3BA58-2YA0	SOFTWARE SIMATIC PCS 7 OS-SERVER REDUNDANCY V9.0 (PO 100)	2)
OS server, Maintenance server				
2		6ES7660-6EF21-3EA0	SIMATIC PCS 7 INDUSTRIAL WORKSTATION IPC847D, CORE I5, OS-SERVER, RAID1 (2 X 1 TB HDD SATA, DATA MIRRORING), 16GB DDR3, INDUSTRIAL ETHERNET (CP1623), PCS 7 V9.0, WINDOWS SERVER 2012 R2 STANDARD EDITION, 64 BIT	
1		6ES7652-3BA58-2YA0	SOFTWARE SIMATIC PCS 7 OS-SERVER REDUNDANCY V9.0 (PO 100)	2)

Required	Optional	Article number	Product description	Note
2		6ES7658-7GB58-0YB0	SOFTWARE SIMATIC PCS 7 MAINTENANCE STATION RUNTIME BASIC PACKAGE V9.0 (incl. SNMP-OPC server license and 100 Asset TAGs)	
2		6ES7658-7GC00-2YB0	SIMATIC PCS 7 MAINTENANCE STATION RUNTIME ASSET-TAGS (1000 TAGs)	
OS client				
3		6ES7660-5FA08-3BA0	SIMATIC PCS 7 INDUSTRIAL WORKSTATION IPC647D, CORE I5, OS-CLIENT, 500 GB HD SATA, 4GB DDR3, PCS 7 V9.0, WINDOWS 10 ENTERPRISE 2015 LTSB 64BIT	
3		6ES7658-2CX58-0YB5	SOFTWARE SIMATIC PCS 7 OS-CLIENT V9.0	
	3	6ES7652-0XD58-2YB5	SOFTWARE SIMATIC PCS 7 SFC VISUALIZATION V9.0	
Automation system				
2		6ES7654-6CP03-3BF0	SIMATIC PCS 7 SINGLE AS, CPU 410-5H, 1X DP-MODULE, 2x PROFINET-IO, SYSTEM EXPANSION CARD 500 PO, AS RT PO 100, CP443-1IE, UR2 ALU RACK, 1 X UC 120/230V 10A POWER SUPPLY	1)
		24 V DC power supply	Redundant power supply	Chapter 17.2

Note

1) Please use the PCS 7 AS configurator, since different versions of the PCS 7 AS 410-5H are available; e. g., 24V DC or 110/230V AC.

2) The redundant OS server is supplied with an RS-232 serial connection cable. If there is a long distance between the redundant systems, you can establish an Ethernet connection as an alternative. This requires additional Ethernet network interface cards in the systems.

13.6 Asset management in flat hierarchies

From PCS 7 V9.0 onwards, a maintenance station can also be used with OS single user systems with the following configuration:

- A Redundant OS single user system (single user system + single user system standby)
- Optional: Up to six non-redundant OS single user systems (as a reference OS from the OS single user system)
- MS as a separate PC station

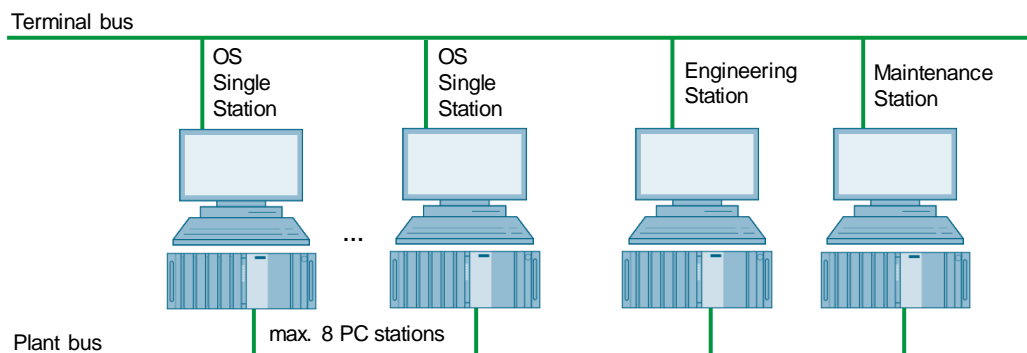

The MS server obtains the data from the ASes via the redundant OS single user system. If the redundant OS single user system is deactivated, the data of the AS are no longer displayed.

Note

Messages generated locally on a reference OS are not displayed in the diagnostic images. For example, self-diagnosis messages are affected by this. The non-accessibility of the reference OSEs via the terminal bus is visualized on the MS server.

To display the diagnostic information on the OS single user systems, a web server must be configured on the MS server.

The diagnostic images of the MS server can be accessed from the OS single user system via WebBrowser control.

There are two ways to access the MS server from the OS single user system:

- Create a user image on the OS single user system in Graphics Designer. Insert a WinCC WebBrowser control into the user image. In the process control interface, you can access the MS via the WinCC WebBrowser control in the user image.
- Start the WebClient functionality via Internet Explorer.

Bill of materials

Required	Optional	Article number	Product description	Note
Engineering Station				
1		6ES7660-6DA10-3BA0	SIMATIC PCS 7 INDUSTRIAL WORKSTATION IPC847D, CORE I5, ES/OS SINGLESTATION, 500 GB HD SATA, 8GB DDR3, BCE, PCS 7 V9.0, WINDOWS 10 ENTERPRISE 2015 LTSB 64BIT	1)
1		6ES7658-5AX58-0YA5	SOFTWARE SIMATIC PCS 7 AS/OS ENGINEERING V9.0	1)
	1	6ES7652-0XD58-2YB5	SOFTWARE SIMATIC PCS 7 SFC VISUALIZATION V9.0	
	1	6ES7658-1CX58-2YA5	SOFTWARE SIMATIC PCS 7 VERSION CROSS MANAGER V9.0	
	1	6ES7658-1FX58-2YA5	SOFTWARE SIMATIC PCS 7 VERSION TRAIL V9.0	
	1	6ES7658-1DX58-2YB5	SOFTWARE SIMATIC PCS 7 IMPORT EXPORT ASSISTANT V9.0	
1		6ES7658-3TD68-0YA5	SOFTWARE SIMATIC PDM PCS 7 SERVER V9.1 (100 TAGs)	1)
	1	6ES7658-3QX68-2YB5	SOFTWARE SIMATIC PDM COMMUNICATION FOUNDATION FIELDBUS V9.1	
1		6ES7658-7GX58-0YB5	SIMATIC PCS 7 MAINTENANCE STATION ENGINEERING V9.0	1)
1		6ES7658-2CX58-0YB5	SOFTWARE SIMATIC PCS 7 OS-CLIENT V9.0	1)
Operator single station				
1	7	6ES7660-6DC10-3BB0	SIMATIC PCS 7 INDUSTRIAL WORKSTATION IPC847D, CORE I5, ES/OS, RAID1 (2 x 1 TB HDD SATA, DATA MIRRORING), 8GB DDR3, MULTI MONITOR 2 SCREENS VIA ONBOARD INTERFACES (ADAPTER CABLE), BCE, PCS 7 V9.0, WINDOWS 10 ENTERPRISE 2015 LTSB 64BIT	
1	7	6ES7658-2AA58-0YA0	SIMATIC PCS 7 OS SOFTWARE SINGLE STATION V9.0 INCL. 100 OS RUNTIME PO	1)
1	7	6ES7652-0XD58-2YB5	SOFTWARE SIMATIC PCS 7 SFC VISUALIZATION V9.0	
		6ES7658-2XA00-0XB0	SIMATIC PCS 7 OS RUNTIME LICENSE (100 TAGS)	
		6ES7658-2EA00-2YB0	SIMATIC PCS 7 OS ARCHIVE (1500 VARIABLES)	
Maintenance Station				
1		6ES7660-6EC10-3EA0	SIMATIC PCS 7 INDUSTRIAL WORKSTATION IPC847D, CORE I5, OS-SERVER, RAID1 (2 X 1 TB HDD SATA, DATA MIRRORING), 8GB DDR3, BCE, PCS 7 V9.0, WIN SERVER 2012 R2 STANDARD EDITION INCL. 5 CLIENT 64BIT	
1		6ES7658-2BA58-0YA0	SOFTWARE SIMATIC PCS 7 OS-SERVER V9.0 (PO 100)	1)
1		6ES7658-7GB58-0YB0	SOFTWARE SIMATIC PCS 7 MAINTENANCE STATION RUNTIME BASIC PACKAGE V9.0 (incl. SNMP-OPC server license and 100 Asset TAGs)	4)
2		6ES7658-7GC00-2YB0	SIMATIC PCS 7 MAINTENANCE STATION RUNTIME ASSET-TAGS (1000 TAGs)	

Required	Optional	Article number	Product description	Note
Automation system				
1		6ES7654-6CN03-3BF0	SIMATIC PCS 7 SINGLE AS, CPU 410-5H, 1X DP-MODULE, 2x PROFINET-IO, SYSTEM EXPANSION CARD 1000 PO, AS RT PO 100, CP443-1IE, UR2 ALU RACK, 1 X UC 120/230V 10A POWER SUPPLY	²⁾
		24 V DC power supply	Redundant power supply	Chapter 17.2

Note

- ¹⁾ The number of POs can be increased later by means of extra volume licenses.
- ²⁾ Please use the PCS 7 AS configurator, since different versions of the PCS 7 AS 410-5H are available; e. g., 24V DC or 110/230V AC.
- ³⁾ The number of PDM TAGs can be increased by means of cumulative TAG licenses.
- ⁴⁾ Note for asset runtime:
 - The number of Asset TAGs can be increased by means of cumulative Asset TAG licenses.
 - An increase of the asset TAGs requires an increase of AS and OS RT process objects for the maintenance server.

13.7 SIMATIC PDM Maintenance Station

This configuration is a single user system based on an IPC Microbox 427E.

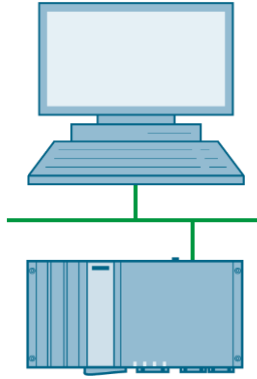

The PDM MS is based on PCS 7 ES software components. However, not all the functions of an ES are available (for example, no CFC editor, no HW configuration for AS systems, etc.). Instead, the project structure is created in the process device network view of PDM. The connection to the process is made to PROFINET networks directly (via internal interface) and to PROFIBUS networks either via S7 CPUs with data set routing or via IE/PB links.

Bill of materials

Required	Optional	Article number	Product description	Note
Engineering Station, Operator Station, Maintenance Station				
1		6ES7650-0RJ02-0YX0	SIMATIC MAINTENANCE STATION PDM V2.0 Complete package comprising the hardware and software for engineering and operation; IPC 427E; Soft-PLC AS RTX 2010, SIMATIC PCS 7 V8.2 COMPACT WITH REDUCED RANGE OF FUNCTIONS; SIMATIC PDM V9.0.1.3; DEVICE LIBRARY 1#2016; SOFTWARE CLASS A, WINDOWS 7 ULTIMATE/32BIT, LICENCE FOR 1 USER, 4 TAGS INCLUDED	1)
	1	6ES7658-3UA00-2YB5	SIMATIC PDM, 1 CLIENT	2)

Note

¹⁾ The number of PDM TAGs can be increased by means of cumulative TAG licenses. A maximum of 500 PDM tags can be used.

²⁾ The total number of PDM client licenses can be increased up to 30.

14 SIMATIC Management Console

The SIMATIC Management Console is a software from the SIMATIC PCS 7 product family. The Management Console provides functions for acquiring inventory data and software administration of a PCS 7 system. Software administration using a central Management Console is more efficient than with a local PCS 7 installation.

14.1 Basic functions of the Management Console

The functions below are available without configuring the Management Console:

- Displaying the computers of a network
In a PCS 7 system, the Management Console can make a connection to the computers on which the “SIMATIC Management Agent” service is installed.
- Assigning computers to the Management Console
- Determining groups that contain computers that have to be managed
- Displaying and exporting messages
- Displaying and exporting the event log

14.2 Functions of the Management Console

Using the Management Console, the following functions are available:

- Functions for software administration
- Functions for determining inventory data

14.2.1 Functions for software administration

The Management Console offers the following functions for central administration of software on assigned computers:

- On the Management Console, it is possible to determine the SIMATIC software that is installed on a computer.
- To install SIMATIC software packages, the Management Console accesses the functions of the respective product setup routine.

The following installation variants are possible:

- Installing new software packages
 - Updating software packages
 - Updating the PCS 7 computer
- Using the Management Console, you can specify common installation steps for a group of computers.

Note

In this connection, consider the article entitled “Which products can you install using the SIMATIC Management Console?”

<https://support.industry.siemens.com/cs/ww/en/view/107796665>

14.2.2 Functions for determining inventory data

The Management Console provides functions for determining the inventory data of the objects in a PCS 7 system.

Objects

The source of the inventory data can be objects of the plant (online data) or objects in project data (offline data). It is possible to determine inventory data for the following objects of the PCS 7 system:

- Calculator
- Network components (Ethernet switches)
- Automation systems
- Remote I/Os (including the I/O assemblies)
- Field devices

Inventory data

Inventory data can include the following information:

- Plant designation (depending on the designation system e. g. AKZ/TAG)
- Geographical position (depending on the designation system e. g. OKZ)
- Description (user-defined)
- Message (user-defined)
- Device name
- Device type
- Serial number
- Article number
- Hardware version
- Firmware version
- Operating system version
- Installed SIMATIC software
- License information (license keys with SIMATIC software)
- Software installed with PCS 7 DVD

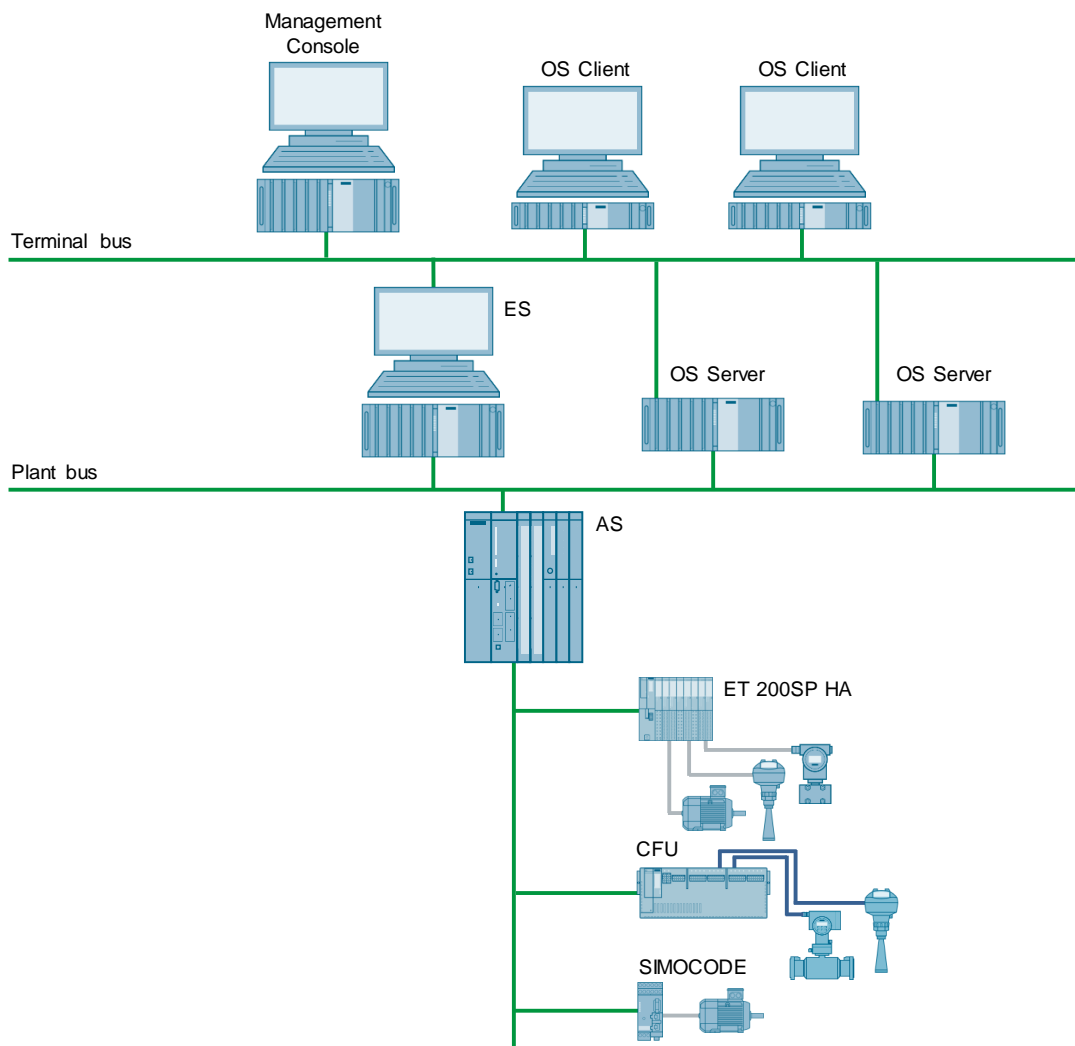

© Siemens AG 2019. All rights reserved.

Bill of materials

Required	Optional	Article number	Product description	Note
Engineering Station, Operator Station and Automation System				
	1		Existing engineering station	1)
1			SEPARATE WIN SERVER 2012 R2	1)
1		6ES7658-5BX58-2YB5	SIMATIC MANAGEMENT CONSOLE V9.0	

Note

¹⁾ Only ever install one Management Console on one network. Using several Management Consoles can result in inconsistencies. If possible, install the Management Console on a computer that is not needed for operator control and monitoring.

The Management Console must **not** be installed on one of the following computers:

- A computer with server functions (e. g. a server or single user system for OS, BATCH, Route Control, or a Domain Controller)
- A computer for acquiring archive data (e. g. Process Historian)

15 Network architecture

15.1 Overview

Star, line and tree structures

The rugged SCALANCE network components, active, and managed switches can be used to build cost-effective network topologies for a large number of nodes.

SCALANCE offers a wide range of network components to create star, line and tree structures with a large number of ports.

If multiple switches are needed to realize a high number of ports or to allow the spatial distribution of the switches, then we suggest that you connect the switches as a fault-tolerant ring to ensure appropriate availability.

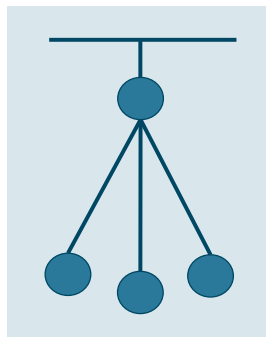

Star

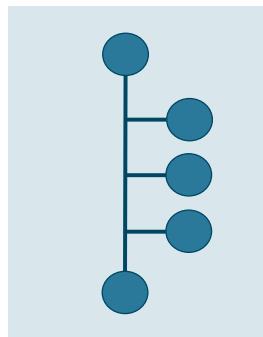

Line

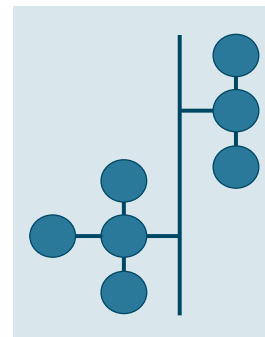

Tree

Fault-tolerant ring

A unique redundancy manager concept enables the administration of several SCALANCE switches faults in a ring backbone for optical, electrical or mixed media process without interrupting the network communication. This function has the complete range of SCALANCE switches (from SCALANCE X200) which are offered with SIMATIC PCS 7.

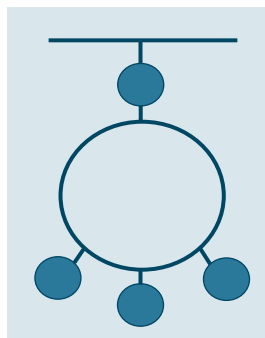

Ring

Redundant bus with fault-tolerant rings

SIMATIC PCS 7 provides redundancy from the OS client right through to the field connection.

Network communication between OS clients and OS servers, as well as between OS servers and AS, can achieve the highest level of availability.

This is the case if each computer and the automation system (two network interfaces per computer and AS) are connected to two separate (redundant) and fault-tolerant networks in ring structure.

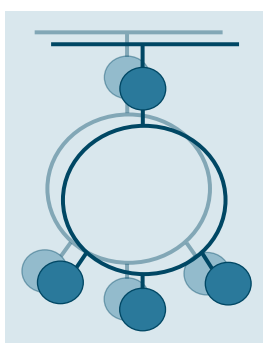

Combined systems and terminal bus

When using a common (combined) plant and terminal bus, pay attention to the article entitled "What are the requirements for operating PCS 7 via common plant and terminal buses?":

<https://support.industry.siemens.com/cs/ww/en/view/43273606>

The use of VLAN (Virtual Local Area Network) technology makes it possible to split a physical network into logical networks. The use of VLAN allows the system bus and the terminal bus to operate together on one physical network.

Note

For more information on configuring a combined system and terminal bus, see the FAQ "How to configure a Virtual Local Area Network (VLAN) in PCS 7?":

<https://support.industry.siemens.com/cs/ww/en/view/66807297>

Backbone networks with 1 to 10 Gbits of bandwidth

For applications where large amounts of data have to be transmitted over the backbone network, the minimum bandwidth of 100 Mbps may no longer be sufficient.

For this purpose, Siemens offers SCALANCE switches with a bandwidth of 1 to 10 Gbit. The high-performance switches deliver the functionality of redundancy management, which makes it possible to set up fault-tolerant ring topologies with single or double redundancy.

15.2 Ring architectures

High-speed ring fault tolerance

Fault-tolerant rings based on the High Speed Redundancy Protocol (HRP) are used to form multiple communication paths between switches. If one of the paths fails, a backup path is activated and communication is ensured.

Unlike "spanning-tree" technology, which provides similar functionality, SCALANCE switches reconfigure the existing communication paths fast enough to avoid connected systems (controllers, servers, clients) suffering a loss of communication. High-speed ring monitoring and reconfiguration is achieved by a SCALANCE switch assuming the role of redundancy manager.

Ring connections between switches can be made via electrical or optical cable connections.

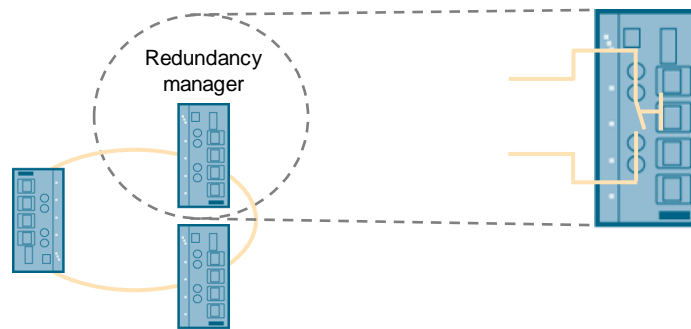

The redundancy manager acts as a switch that opens the Ethernet ring at a predetermined position and controls the cable status. If an error occurs in the cable, the redundancy manager recognizes this, closes the switch, and re-establishes communication.

Ring connectivity, standby redundancy

To connect two separate fault-tolerant Ethernet rings on a redundant basis, there is a second high-speed redundancy function. Although it is necessary to have two connections between the rings for redundancy, only one connection can be active in each case.

To achieve this, one of the two rings to be coupled is equipped with two switches that support the so-called standby redundancy. In this concept, two parallel point-to-point connections monitor each other to ensure that the stand-by connection is activated when the active link fails.

This is achieved by configuring a SCALANCE switch as the standby master and a second SCALANCE switch as the standby slave.

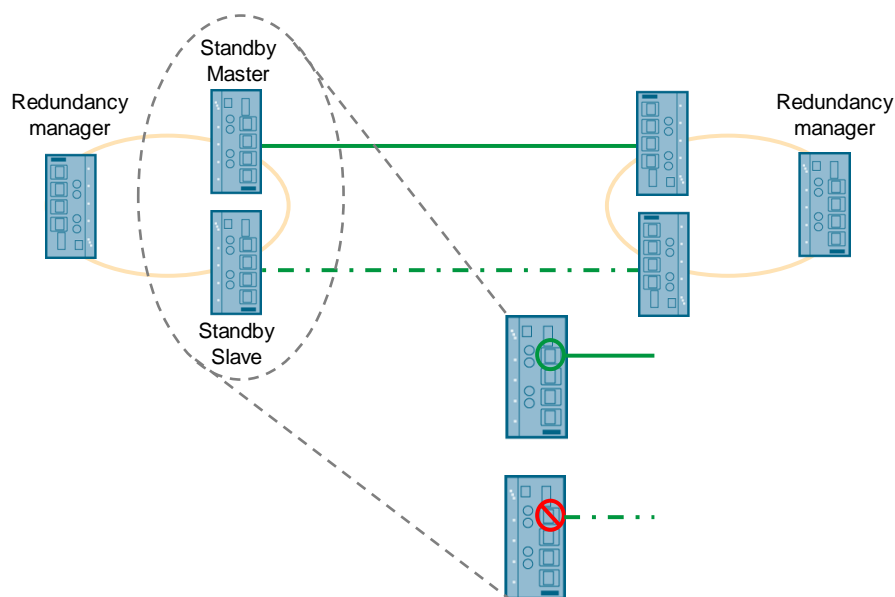

The standby master and standby slave are logically linked. The standby master activates its link and the standby slave deactivates its own link. Both switches monitor each other's status and the standby slave becomes active if the active connection fails.

The fast activation of the standby slave does not cause a breakdown of the communication between the connected systems (controller, server, clients).

15.3 Redundancy concepts - terminal bus

15.3.1 Introduction

OS servers / clients as well as engineering systems, BATCH servers / clients, Route Control server / client and central archive servers can be equipped with a redundant terminal bus connection.

In principle, the structure of this redundant, highly available terminal bus uses the SIMATIC NET SOFTNET-IE RNA software. This software is based on the Parallel Redundancy Protocol (PRP) as per IEC 62439-3.

SIMATIC NET IE RNA

At each PC station, two of the physically present network cards are also combined into one logical network card.

Only the logical network card that has one IP and MAC address is visible to the operating system and the network. Both network cards operate internally using the Parallel Redundancy Protocol (PRP).

The data packets are transmitted in-parallel via both network cards. The first incoming message frame is processed at the receiver end. The message frame sent in-parallel is discarded.

Due to the parallel data transfer, a redundant bus must be used without connection between the fault-tolerant Ethernet rings, see chapter 15.1. Due to the parallel transmission, if an error occurs there is a 0 ms switchover time.

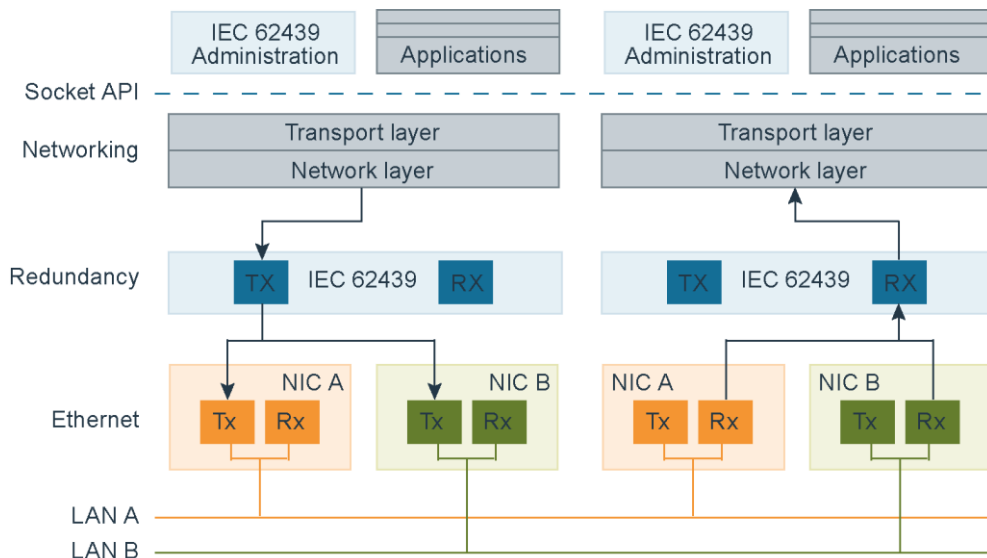

15.3.2 Redundant terminal bus

SIMATIC NET SOFTNET IE-RNA redundant network

- Redundant terminal bus connection in every server and client
- Redundant bus with fault-tolerant Ethernet rings

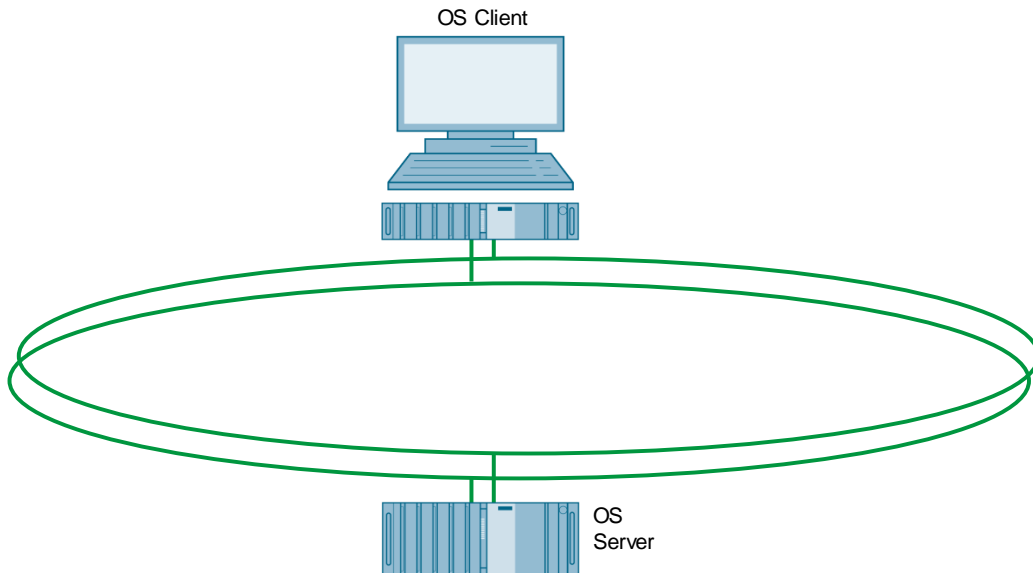

© Siemens AG 2019. All rights reserved

Bill of materials

Required	Optional	Article number	Product description	Note
Operator system server				
1		6GK1711-1EW14-0AA0	SIMATIC NET SOFTNET-IE RNA V14 REDUNDANT NETWORK ACCESS	1) 2)
Operator system client				
1		6GK1711-1EW14-0AA0	SIMATIC NET SOFTNET-IE RNA V14 REDUNDANT NETWORK ACCESS	1) 2)

Note

SCALANCE switch and network components must be added. Please note the descriptions of the network topology in this chapter to select the appropriate configuration and components.

1) The onboard interfaces can be used.

2) Single license for one installation.

15.4 Redundancy concepts - plant bus

15.4.1 Introduction

Besides the fault-tolerant ring and redundant bus concepts described above, PCS 7 also provides flexible redundancy solutions for communication via the plant bus between OS and AS (controllers).

For redundant communication, SIMATIC S7-400H controllers (as standard or H system), SCALANCE network components, the communication processor CP1623/1628 or corresponding standard network cards (BCE) with the software "HARDNET-IE S7-REDCONNECT" or "SOFTNET-IE S7 REDCONNECT VM" are required for the computers involved.

15.4.2 Standard automation system

The AS 410 standard automation systems consist of an S7-410-5H controller. The connection to the plant bus can either be established via the CP 443-1 communication module or, for S7-410-5H controllers with firmware (FW) V8.1 or higher, via the PROFINET-IO interfaces integrated into the CPU. The following must be considered:

- When using a PROFINET-IO interface for the plant bus, it must not be used for PROFINET.
- For system-related reasons, the two PROFINET-IO interfaces must be located in different IP subnets.

You can find additional information at

<https://support.industry.siemens.com/cs/ww/en/view/109748473>

Note

You can find the file for upgrading the CPU 410-5H firmware in the download article "Operating System Update: CPU410-5H Process Automation":
<https://support.industry.siemens.com/cs/ww/en/view/109476571>

To support redundant communication with FW V8.0, you can equip a station with two CP443-1 Ethernet communication processors.

Various redundancy configurations are listed below as examples:

- Concept 1, single network, single OS server/single-user network connection, two communication paths
 - one CP1623 in the OS server, single-user
 - two CP443-1 communication processors
 - Star network or fault-tolerant ring
- Concept 2, redundant network, redundant OS server/single-user network connection, two communication paths
 - two CP1623 in the OS server, single-user
 - two CP443-1 communication processors or PROFINET-IO interfaces
 - redundant bus with two fault-tolerant rings

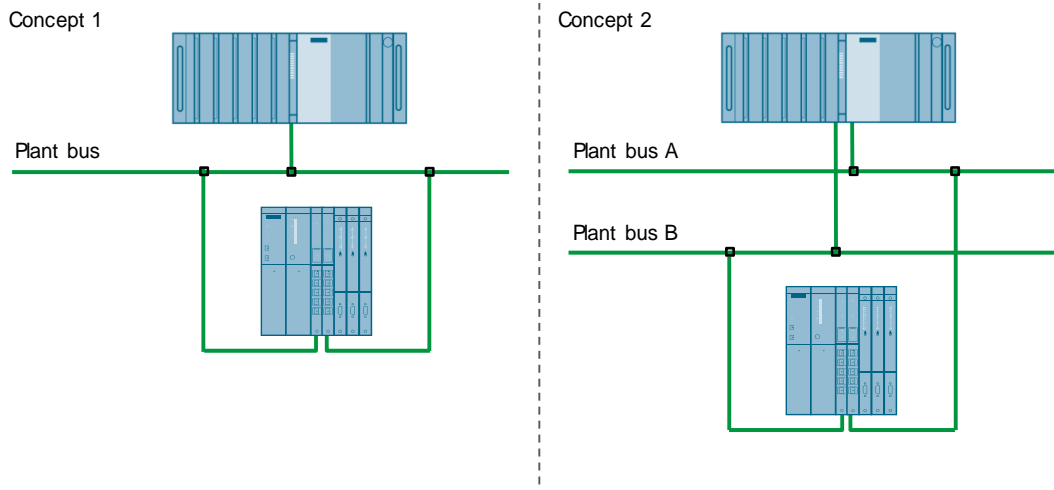

© Siemens AG 2019. All rights reserved.

Bill of material for concept 1

Required	Optional	Article number	Product description	Note
Automation system				
1		6ES7654-6CL04-3BF0	SIMATIC PCS 7 SINGLE AS, CPU 410-5H, 1X DP-MODULE, 2x PROFINET-IO, SYSTEM EXPANSION CARD 500 PO, AS RT PO 100, 2 X CP443-1IE, UR2 ALU RACK, 1 X UC 120/230V 10A POWER SUPPLY	1)
Engineering system and Operator system				
1		6GK1716-0HB14-0AC0	SIMATIC NET, S7-REDCONNECT POWERPACK V14	2)

Bill of materials for concept 2

Required	Optional	Article number	Product description	Note
Automation system				
1		6ES7654-6CL04-3BF0	SIMATIC PCS 7 SINGLE AS, CPU 410-5H, 1X DP-MODULE, 2x PROFINET-IO, SYSTEM EXPANSION CARD 500 PO, AS RT PO 100, 2 X CP443-1IE, UR2 ALU RACK, 1 X UC 120/230V 10A POWER SUPPLY	
Engineering system and Operator system				
1		6GK1716-0HB14-0AC0	SIMATIC NET, S7-REDCONNECT POWERPACK V14	1)
1		6GK1162-3AA00	SIMATIC NET COMMUNICATION PROCESSOR CP1623 PCI EXPRESS	1) 2)

Note

SCALANCE switch and network components must be added. Please note the descriptions of the network topology in this chapter to select the appropriate configuration and components.

1) REDCONNECT POWERPACKs and CP1623 are needed for each Operator System and Engineering System in which a CP1623 is installed.

2) The bill of material is based on the assumption that the selected operator system and engineering system hardware is equipped with a CP1623 (industrial Ethernet version of the hardware). Only additional CP1623 communication processors are listed.

15.4.3 High-availability automation system AS 410

Highly available AS 410 automation systems consist of two S7-410-5H controllers. For communication, you can use the PROFINET-IO interfaces with firmware V8.1 and up, or equip the 410-5H controllers with two redundant CP443-1 or four redundant CP443-1 communication processors. With regard to the PROFINET-IO interfaces, the following must be observed:

- When using a PROFINET-IO interface for the plant bus, it must not be used for PROFINET.
- For system-related reasons, the two PROFINET-IO interfaces must be located in different IP subnets.

You can find additional information at

<https://support.industry.siemens.com/cs/ww/en/view/109748473>

Various redundancy configurations are listed below as examples:

- Concept 1, single network, single OS server/single-user network connection, two communication paths
 - one CP1623 in the OS server, single-user
 - two CP443-1 communication processors
 - Star network or fault-tolerant ring
- Concept 2, redundant network, redundant OS server/single-user network connection, two communication paths
 - two CP1623 in the OS server, single-user
 - two CP443-1 communication processors or PROFINET-IO interfaces
 - redundant fault-tolerant rings
- Concept 3, redundant network, redundant OS server/single-station network connection, four communication channels
 - two CP1623 in the OS server, single-user
 - four CP443-1 communication processors
 - redundant fault-tolerant rings

Concept 1

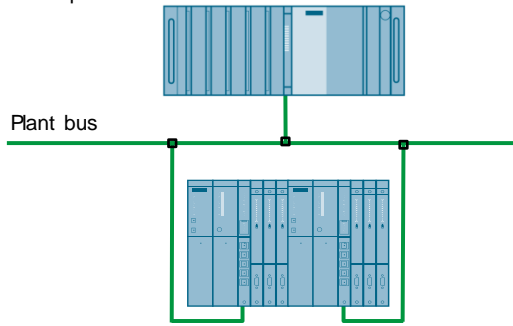

Concept 2

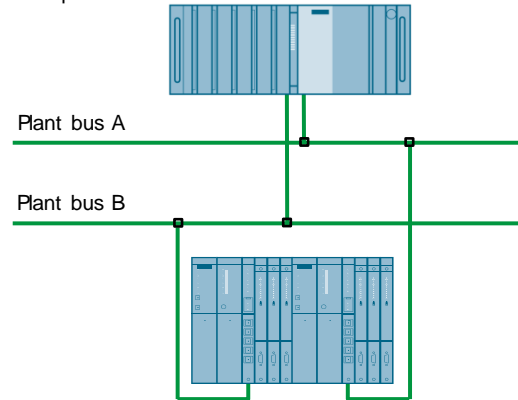

Concept 3

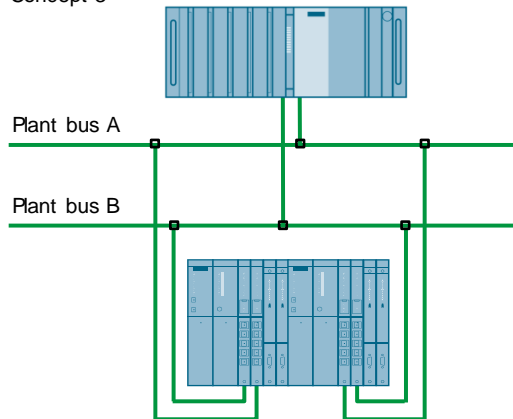

Bill of material for concept 1

Required	Optional	Article number	Product description	Note
Automation system				
1		6ES7656-6CL33-1CF0	SIMATIC PCS 7 REDUNDANCY AS, 2X CPU 410-5H, 2 DP-MODULE, 2X PROFINET-IO, 2 X CP443-1IE, SYSTEM EXPANSION CARD 500 PO, AS RT PO 100, 2 X 2 10M SYNC-MODULE AND 2 X 1M FO, 1 X UR2-H ALU RACK, 2 X UC 120/230V 10A RED. POWER SUPPLY	3)
Engineering system and Operator system				
1		6GK1716-0HB14-0AC0	SIMATIC NET, S7-REDCONNECT POWERPACK V14	1)

Bill of materials for concept 2

Required	Optional	Article number	Product description	Note
Automation system				
1		6ES7656-6CL33-1CF0	SIMATIC PCS 7 REDUNDANCY AS, 2X CPU 410-5H, 2 DP-MODULE, 2X PROFINET-IO, 2 X CP443-1IE, SYSTEM EXPANSION CARD 500 PO, AS RT PO 100, 2 X 2 10M SYNC-MODULE AND 2 X 1M FO, 1 X UR2-H ALU RACK, 2 X UC 120/230V 10A RED. POWER SUPPLY	3)
Engineering system and Operator system				
1		6GK1716-0HB14-0AC0	SIMATIC NET, S7-REDCONNECT POWERPACK V14	1)
1		6GK1162-3AA00	SIMATIC NET COMMUNICATION PROCESSOR CP1623 PCI EXPRESS	1) 2)

Bill of material for concept 3

Required	Optional	Article number	Product description	Note
Automation system				
1		6ES7656-6CL34-1CF0	SIMATIC PCS 7 REDUNDANCY AS, 2X CPU 410-5H, 2 DP-MODULE, 2X PROFINET-IO, 2x2 CP443-1IE, SYSTEM EXPANSION CARD 500 PO, AS RT PO 100, 2 X 2 10M SYNC-MODULE AND 2 X 1M FO, 1 X UR2-H ALU RACK, 2 X UC 120/230V 10A RED. POWER SUPPLY	1) 2)
Engineering system and Operator system				
1		6GK1716-0HB14-0AC0	SIMATIC NET, S7-REDCONNECT POWERPACK V14	3)
1		6GK1162-3AA00	SIMATIC NET COMMUNICATION PROCESSOR CP1623 PCI EXPRESS	3) 4)

Note

SCALANCE switch and network components must be added. Please note the descriptions of the network topology in this chapter to select the appropriate configuration and components.

1) Please use the PCS 7 AS configurator, since different versions of the PCS 7 AS 410 are available; e. g., 24 V DC or 110/230V AC.

2) With a concept 2 configuration (redundant network with four communication channels) the connection of the CP443-1 to the Plant bus must be done crosswise ("ABBA"), to enable the configuration of the four communication channels in NetPro.

3) REDCONNECT POWERPACKs and CP1623 are needed for each Operator System and Engineering System that is integrated in the system bus.

4) The bill of material is based on the assumption that the selected Operator System and Engineering System hardware is equipped with a CP1623 (industrial Ethernet version of the hardware); only additional CP1623 communications processors are listed.

15.5 Exemplary configurations

This chapter shows configurations for plant and terminal buses based on the redundancy concepts presented in chapter 15.3 and chapter 15.4. The focus is on the components required for the network infrastructure, which are listed in the bill of materials.

15.5.1 Fault-tolerant ring architectures with glass fiber

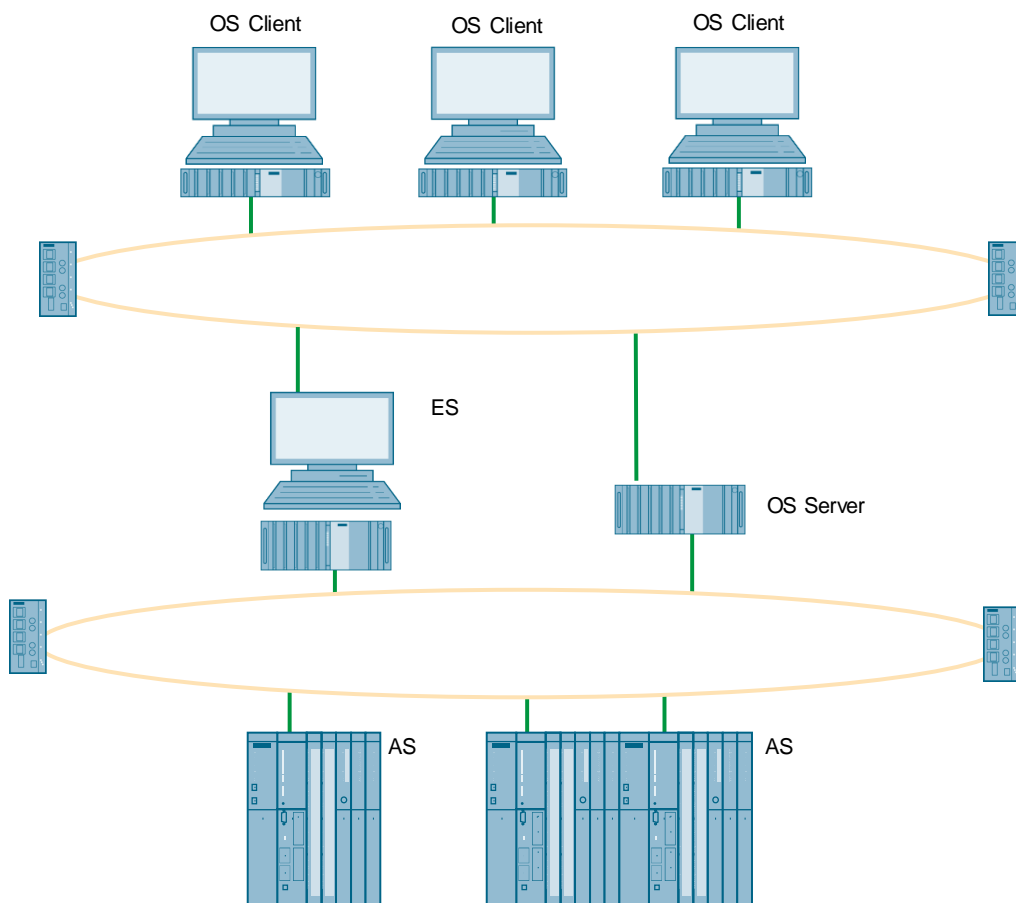

Bill of materials

Required	Optional	Article number	Product description	Note
Terminal bus				
2		6GK5206-2BB00-2AC2	SCALANCE XC206-2 MANAGEABLE LAYER 2 IE-SWITCH; 6X 10/100 MBIT/S RJ45 PORTS; 2X 100 MBIT/S ST/BFOC-PORTS	1)
2		6XV1820-5BN10	SIMATIC NET, FIBER OPTIC CABLE, 4 BFOC CONNECTORS, 10M	
5		6XV1870-3QH60	SIMATIC NET INDUSTRIAL ETHERNET TP CORD CABLE RJ45/RJ45, 6M	
		24 V DC power supply	Redundant power supply	Chapter 17.2
Plant bus				
2		6GK5206-2BB00-2AC2	SCALANCE XC206-2 MANAGEABLE LAYER 2 IE-SWITCH; 6X 10/100 MBIT/S RJ45 PORTS; 2X 100 MBIT/S ST/BFOC-PORTS	1)
2		6XV1820-5BN10	SIMATIC NET, FIBER OPTIC CABLE, 4 BFOC CONNECTORS, 10M	
6		6XV1870-3QH60	SIMATIC NET INDUSTRIAL ETHERNET TP CORD CABLE RJ45/RJ45, 6M	
		24 V DC power supply	Redundant power supply	Chapter 17.2

Note

¹⁾ SCALANCE witch needs a 24V DC power supply.

15.5.2 Electrical fault-tolerant ring architectures

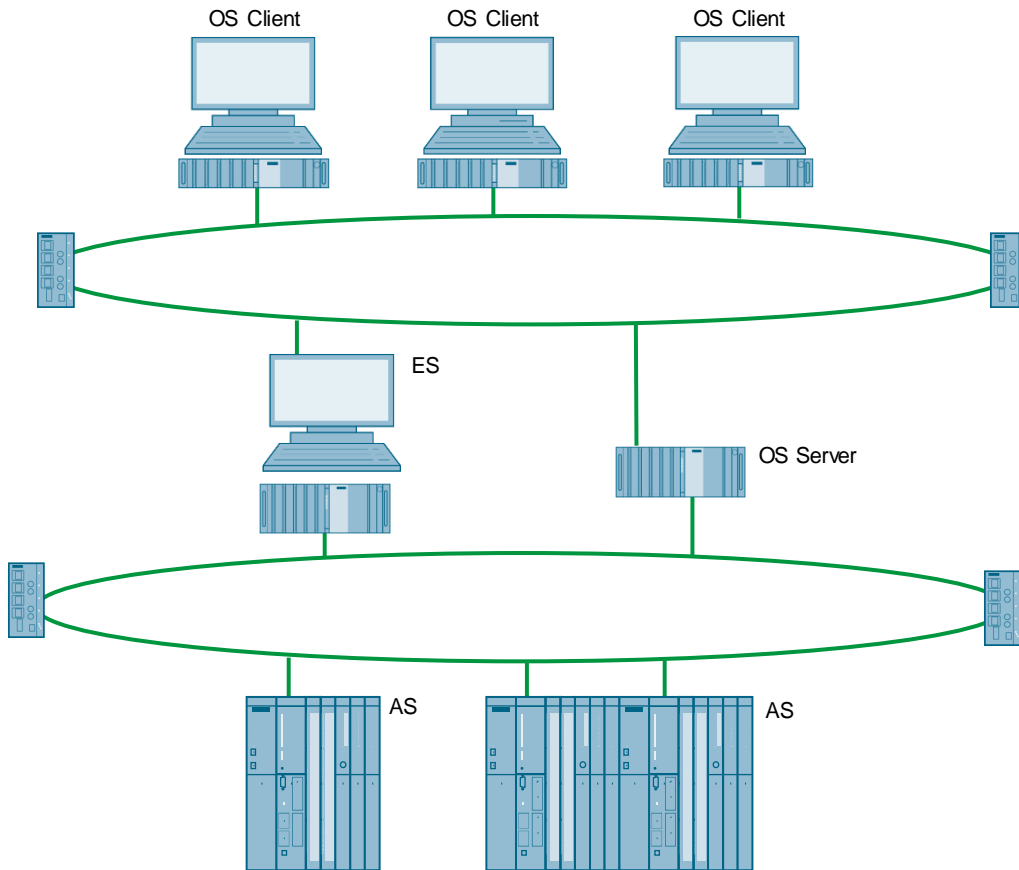

© Siemens AG 2019. All rights reserved.

Bill of materials

Required	Optional	Article number	Product description	Note
Terminal bus				
2		6GK5208-0BA00-2AC2	SCALANCE XC208 MANAGEABLE LAYER 2 IE-SWITCH; 8X 10/100 MBIT/S RJ45 PORTS	1)
7		6XV1870-3QH60	SIMATIC NET INDUSTRIAL ETHERNET TP CORD CABLE RJ45/RJ45, 6M	
		24 V DC power supply	Redundant power supply	Chapter 17.2
Plant bus				
2		6GK5208-0BA00-2AC2	SCALANCE XC208 MANAGEABLE LAYER 2 IE-SWITCH; 8X 10/100 MBIT/S RJ45 PORTS	1)
8		6XV1870-3QH60	SIMATIC NET INDUSTRIAL ETHERNET TP CORD CABLE RJ45/RJ45, 6M	
		24 V DC power supply	Redundant power supply	Chapter 17.2

Note

1) SCALANCE witch needs a 24V DC power supply.

15.5.3 Electrical fault-tolerant ring structures with combined plant and terminal bus

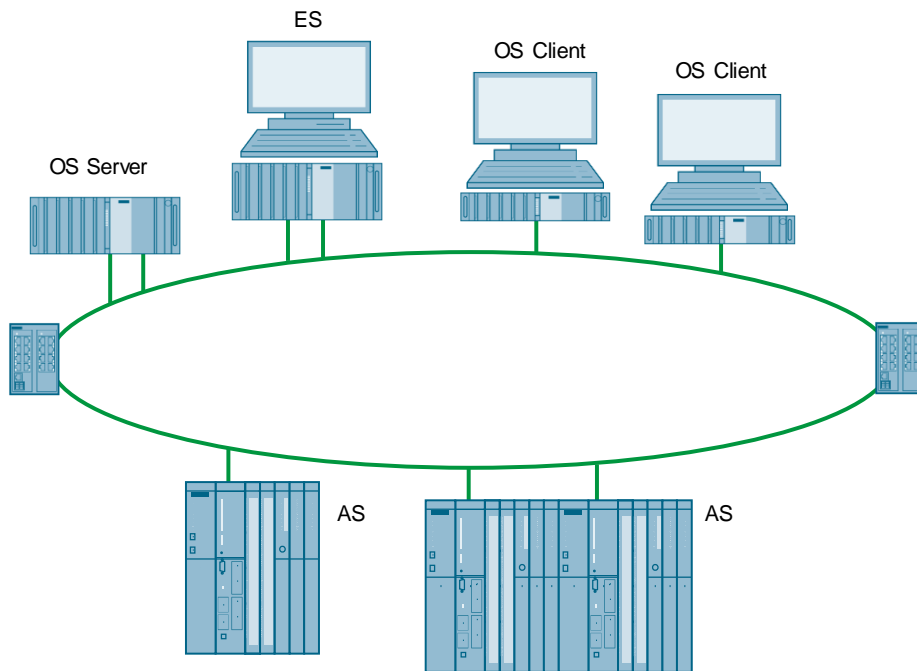

Bill of materials

Required	Optional	Article number	Product description	Note
Shared plant and terminal bus				
2		6GK5216-0BA00-2AC2	SCALANCE XC216 MANAGEABLE LAYER 2 IE-SWITCH; 16X 10/100 MBIT/S RJ45 PORTS	1)
11		6XV1870-3QH60	SIMATIC NET INDUSTRIAL ETHERNET TP CORD CABLE RJ45/RJ45, 6M	
		24 V DC power supply	Redundant power supply	Chapter 17.2

Note

1) SCALANCE witch needs a 24V DC power supply.

In spite of the common network, separate network cards are required for the terminal and system bus.

15.5.4 Redundant bus architectures with fault-tolerant rings

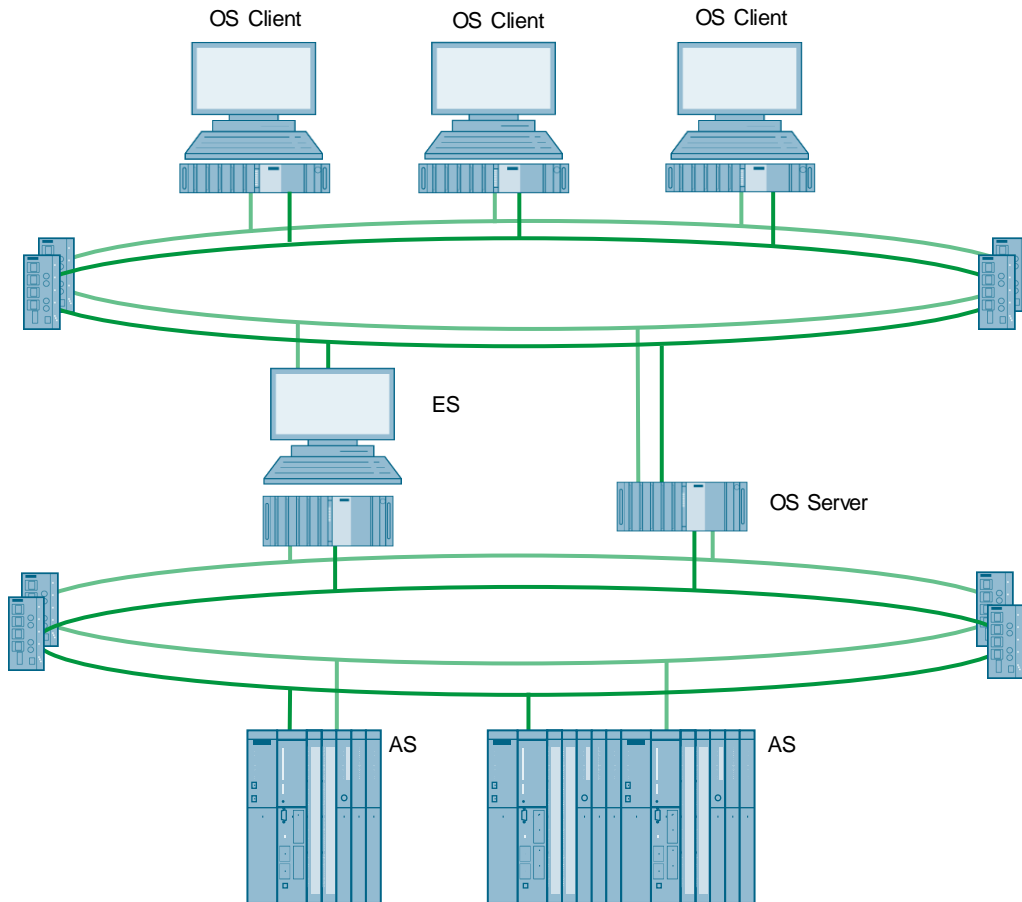

© Siemens AG 2019. All rights reserved

Bill of materials

Required	Optional	Article number	Product description	Note
Terminal bus				
4		6GK5206-2BB00-2AC2	SCALANCE XC206-2 MANAGEABLE LAYER 2 IE-SWITCH; 6X 10/100 MBIT/S RJ45 PORTS; 2X 100 MBIT/S ST/BFOC-PORTS	1)
4		6XV1820-5BN10	SIMATIC NET, FIBER OPTIC CABLE, 4 BFOC CONNECTORS, 10M	
12		6XV1870-3QH60	SIMATIC NET INDUSTRIAL ETHERNET TP CORD CABLE RJ45/RJ45, 6M	
		24 V DC power supply	Redundant power supply	Chapter 17.2

Required	Optional	Article number	Product description	Note
Plant bus				
4		6GK5206-2BB00-2AC2	SCALANCE XC206-2 MANAGEABLE LAYER 2 IE-SWITCH; 6X 10/100 MBIT/S RJ45 PORTS; 2X 100 MBIT/S ST/BFOC-PORTS	1)
4		6XV1820-5BN10	SIMATIC NET, FIBER OPTIC CABLE, 4 BFOC CONNECTORS, 10M	
8		6XV1870-3QH60	SIMATIC NET INDUSTRIAL ETHERNET TP CORD CABLE RJ45/RJ45, 6M	
		24 V DC power supply	Redundant power supply	Chapter 17.2

Note 1) SCALANCE witch needs a 24V DC power supply.

15.5.5 Redundant bus architectures with fault-tolerant rings and combined plant and terminal bus

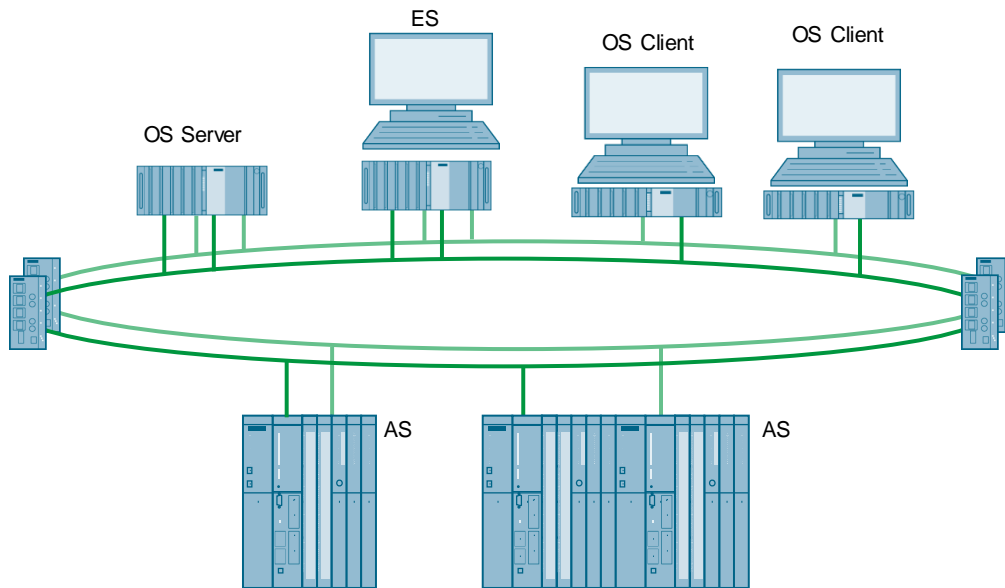

Bill of materials

Required	Optional	Article number	Product description	Note
Combined plant and terminal bus				
4		6GK5206-2BB00-2AC2	SCALANCE XC206-2 MANAGEABLE LAYER 2 IE-SWITCH; 6X 10/100 MBIT/S RJ45 PORTS; 2X 100 MBIT/S ST/BFOC-PORTS	1)
4		6XV1820-5BN10	SIMATIC NET, FIBER OPTIC CABLE, 4 BFOC CONNECTORS, 10M	
20		6XV1870-3QH60	SIMATIC NET INDUSTRIAL ETHERNET TP CORD CABLE RJ45/RJ45, 6M	
		24 V DC power supply	Redundant power supply	Chapter 17.2

Note

1) SCALANCE witch needs a 24V DC power supply.

In spite of the common network, separate network cards are required for the terminal and system bus.

16 Process safety

The "Safety Integrated for Process Automation" concept enables the complete integration of safety technology (Process Safety) into the SIMATIC PCS 7 process control system.

As a general rule, when setting up a PCS 7 system with process safety, the same scalable and flexible architectures are possible as for systems without process safety.

It should be noted that a safety-oriented automation system, also known as a fail-safe automation system (F/FH system), is required for the execution of safety-related user programs.

This prerequisite is already met on the hardware side by the AS 410 modular automation system used in the configurations of this document.

Additionally, the license "SIMATIC S7 F Systems Runtime License" is required for each automation system. This is already included in the AS bundles for safety-related automation systems.

The engineering of the safety-related user program can be carried out either with SIMATIC S7 F systems based on CFC logic or optionally with the additional SIMATIC Safety Matrix software based on a cause & effect matrix.

Bill of materials

Required	Optional	Article number	Product description	Note
Additional components required				
1		6ES7833-1CC00-6YX0	SIMATIC S7 F SYSTEMS RUNTIME LICENSE	1)
Engineering Station and Operator Station				
1		6ES7833-1CC26-0YA5	SOFTWARE SIMATIC S7 F SYSTEMS V6.2	
	1	6ES7833-1SM02-0YA5	SOFTWARE SIMATIC SAFETY MATRIX TOOL V6.2	
	1	6ES7833-1SM62-0YA5	SOFTWARE SIMATIC SAFETY MATRIX VIEWER V6.2	2)

Note

1) For the processing of safety-related user programs, a license is required for each AS 410 automation system (independent of whether standard or highly available AS is used). This is already included in the AS bundles for safety-related automation systems.

2) For operating and monitoring the SIMATIC Safety Matrix, a license is required for each OS Single Station/OS client.

17 24 V DC supply concepts

High availability

A reliable power supply is a basic condition for plant operation. With MTBF ratings of up to 1 million hours at full load in continuous operation, SITOP power supplies meet the particularly stringent requirements of processing industries. To further increase availability, the system supports redundant establishment of the power supply as well as buffer operation in the case of a power failure.

Universal application

To allow use all over the world, one and three-phase SITOP power supplies have a wide temperature range of -25 ...+70 °C. In addition, they have a wide range of different international approvals (e. g. ATEX, Class I Div2, IECex, GL, ABS, etc.), which means that you can use them all over the world.

Scalability

SITOP power supplies have different output power levels of up to 1000W, which allows you to tailor them to match your system configuration and layout. Depending on your requirements, you can combine them with redundancy, selectivity or DC UPS modules. This means that you can expand the system on an individual basis up to complete all-round protection.

Notes

In the next few sub-sections, we will describe preferred 24 V supply concepts. Depending on your requirements, you can combine them with different components (e. g. buffered power supply with selective monitoring).

The SITOP library is available for preferred power supply concepts with blocks and faceplates for direct integration into SIMATIC PCS 7. The PCS 7 user automatically receives information on operating conditions (e. g. buffer operation), maintenance requirements (e. g. replacing batteries) and disturbances (e. g. short circuits or overloads in 24V circuits).

SITOP library for SIMATIC PCS 7:

<https://support.industry.siemens.com/cs/ww/en/view/109476154>

17.1 Basic power supplies

Single- and three-phase SITOP modular units are the technology power supplies for demanding solutions. The wide-range input makes it possible to connect to almost any electrical power system worldwide and ensures a high degree of safety even when large voltage fluctuations occur.

They offer outstanding overload characteristics: Power boost delivers up to three-times the rated current for short periods of time, and with extra power of 150%, loads with high power consumption can be connected without any problems.

The very high efficiency keeps energy consumption and heat dissipation in the control cabinet very low and the compact metal housing also saves space.

Single-phase power supplies of S7-300 design can be mounted directly onto S7 rails. The range switchover to 1-phase 120/230 V AC grids takes place automatically.



Bill of materials

Article number	Product description
INPUT: 120/230 V AC, OUTPUT: 24 V / 5 A DC	
6ES7307-1EA01-0AA0	SIMATIC S7-300 PS307 STABILIZED POWER SUPPLY
6EP3333-8SB00-0AY0	SITOP PSU8200 24V/5A STABILIZED POWER SUPPLY
INPUT: 120/230 V AC, OUTPUT: 24 V/10 A DC	
6ES7307-1KA02-0AA0	SIMATIC S7-300 PS307 STABILIZED POWER SUPPLY
6EP3334-8SB00-0AY0	SITOP PSU8200 24V/10A STABILIZED POWER SUPPLY
INPUT: 120-230 V AC 110-220 V DC, OUTPUT: 24 V/20 A DC	
6EP1336-3BA10	SITOP PSU8200 20A STABILIZED POWER SUPPLY
INPUT: AC 120-230 V AC, OUTPUT: 24 V/40 A DC	
6EP3337-8SB00-0AY0	SITOP PSU8200 40A STABILIZED POWER SUPPLY
INPUT: 3 AC 400-500 V, OUTPUT: 24 V/20 A DC	
6EP3436-8SB00-0AY0	SITOP PSU8200 24V/20A STABILIZED POWER SUPPLY
INPUT: 3 AC 400-500 V, OUTPUT: 24 V/40 A DC	
6EP1437-3BA10	SITOP PSU8200 24V/40A STABILIZED POWER SUPPLY

17.2 Redundant power supply

The SITOP redundancy modules provide additional protection against failure of the 24 V supply. Decoupling the two power supply units of the same type by means of a redundancy module means that a failure of one power supply unit has no effect on the 24 V power supply.

The redundancy module continuously monitors the feeding power supply units. If a unit fails, the other one automatically supplies the power. In addition, signaling is carried out by means of a signal contact that is evaluated in SIMATIC PCS 7.

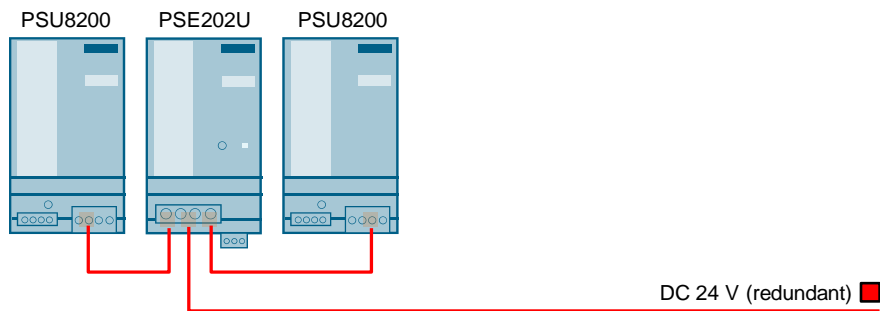

Bill of materials

Article number	Product description	Quantity
INPUT: 120/230 V AC, OUTPUT: 24 V/10 A DC		
6EP3334-8SB00-0AY0	SITOP PSU8200 24V/10A STABILIZED POWER SUPPLY	2
6EP1961-3BA21	SITOP PSE202U REDUNDANCY MODULE INPUT/OUTPUT: 24V/40A DC	1
INPUT: 120-230 V AC 110-220 V DC, OUTPUT: 24 V/20 A DC		
6EP1336-3BA10	SITOP PSU8200 24V/20A STABILIZED POWER SUPPLY	2
6EP1961-3BA21	SITOP PSE202U REDUNDANCY MODULE INPUT/OUTPUT: 24V/40A DC	1
INPUT: AC 120-230 V AC, OUTPUT: 24 V/40 A DC		
6EP3337-8SB00-0AY0	SITOP PSU8200 24V/40A STABILIZED POWER SUPPLY	2
6EP1961-3BA21	SITOP PSE202U REDUNDANCY MODULE INPUT/OUTPUT: 24V/40A DC	2
INPUT: 3 AC 400-500 V, OUTPUT: 24 V/20 A DC		
6EP3436-8SB00-0AY0	SITOP PSU8200 24V/20A STABILIZED POWER SUPPLY	2
6EP1961-3BA21	SITOP PSE202U REDUNDANCY MODULE INPUT/OUTPUT: 24V/40A DC	1
INPUT: 3 AC 400-500 V, OUTPUT: 24 V/40 A DC		
6EP1437-3BA10	SITOP PSU8200 24V/40A STABILIZED POWER SUPPLY	2
6EP1961-3BA21	SITOP PSE202U REDUNDANCY MODULE INPUT/OUTPUT: 24V/40A DC	2

17.3 Redundant power supply system

For the redundant configuration of a PSU8600 power supply, the basic devices with one output and the redundancy module PSE202U can be used.

They are integrated into the control system via PROFINET. Comprehensive operating and diagnostic information is available such as the voltage and current values of the outputs.

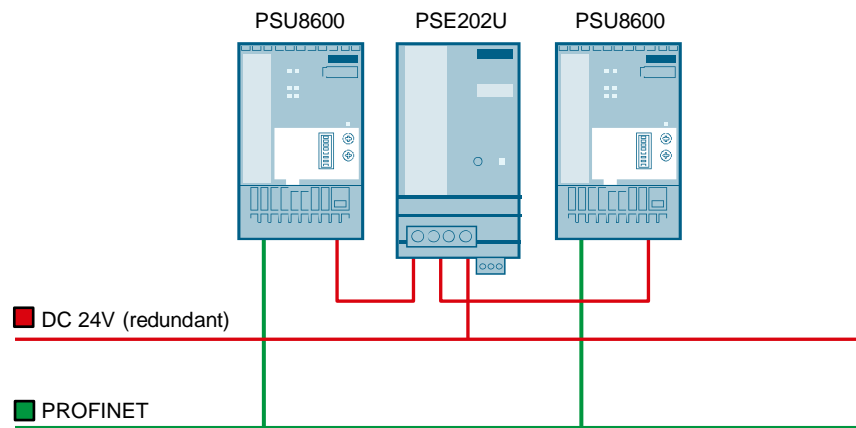

Bill of materials

Article number	Product description	Quantity
INPUT: 3 AC 400-500 V, OUTPUT: 24 V DC/20 A		
6EP3436-8SB00-2AY0	SITOP PSU8600 20 A PN regulated power supply	2
6EP1961-3BA21	SITOP PSE202U REDUNDANCY MODULE INPUT/OUTPUT: DC 24V / 40A	1
INPUT: 3 AC 400-500 V, OUTPUT: 24 V DC/40 A		
6EP3437-8SB00-2AY0	SITOP PSU8600 24 V / 40 A Regulated power supply	2
6EP1961-3BA21	SITOP PSE202U REDUNDANCY MODULE INPUT/OUTPUT: 24V / 40A DC	2

17.4 Redundant power supply with selective monitoring of the 24 V feeders

SITOP selectivity modules are an optimum enhancement for all 24 V power supplies to distribute the load current to several feeders and to monitor it. Overloads and short-circuits in one or more feeders are detected reliably.

This is ensured even on high-resistance lines and in the case of "creeping" short-circuits. The intact feeders continue to supply the SITOP selectivity modules with 24 V on an absolutely interruption- and reaction-free basis. Their signal contact can be looped across several selectivity modules and can be evaluated as a common alarm in SIMATIC PCS 7.

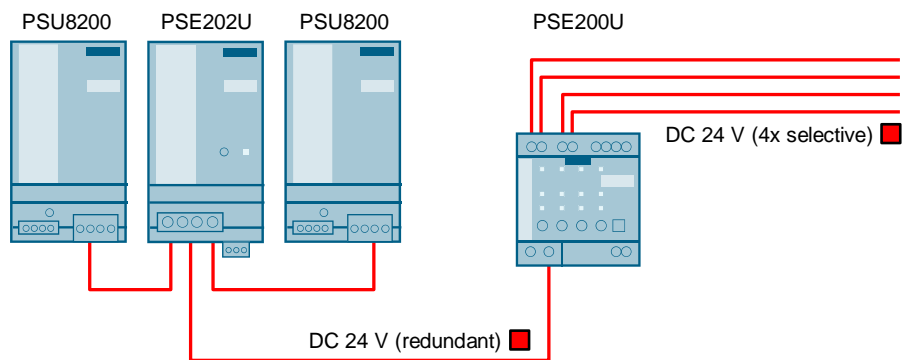

Article number	Product description	Quantity
INPUT: 120/230 V AC, OUTPUT: 24 V/10 A DC		
6EP3334-8SB00-0AY0	SITOP PSU8200 24V/10A STABILIZED POWER SUPPLY	2
6EP1961-3BA21	SITOP PSE202U REDUNDANCY MODULE INPUT/OUTPUT: 24V/40A DC	1
6EP1961-2BA11	SITOP PSE200U 3 A SELECTIVITY MODULE 4-CHANNEL OUTPUT CURRENT CAN BE SET TO 0.5-3 PER CHANNEL	1 ¹⁾
INPUT: 120-230 V AC 110-220 V DC, OUTPUT: 24 V/20 A DC		
6EP1336-3BA10	SITOP PSU8200 20A STABILIZED POWER SUPPLY	2
6EP1961-3BA21	SITOP PSE202U REDUNDANCY MODULE INPUT/OUTPUT: 24V/40A DC	1
6EP1961-2BA21	SITOP PSE200U 10 A SELECTIVITY MODULE 4-CHANNEL OUTPUT CURRENT CAN BE SET TO 3-10 PER CHANNEL	1 ¹⁾

Article number	Product description	Quantity
INPUT: AC 120-230 V AC, OUTPUT: 24 V/40 A DC		
6EP3337-8SB00-0AY0	SITOP PSU8200 40A STABILIZED POWER SUPPLY	2
6EP1961-3BA21	SITOP PSE202U REDUNDANCY MODULE INPUT/OUTPUT: 24V/40A DC	2
6EP1961-2BA21	SITOP PSE200U 10 A SELECTIVITY MODULE 4-CHANNEL OUTPUT CURRENT CAN BE SET TO 3-10 PER CHANNEL	1 ¹⁾
INPUT: 3 AC 400-500 V, OUTPUT: 24 V/20 A DC		
6EP3436-8SB00-0AY0	SITOP PSU8200 24 V/20 A STABILIZED POWER SUPPLY	2
6EP1961-3BA21	SITOP PSE202U REDUNDANCY MODULE INPUT/OUTPUT: 24V/40A DC	1
6EP1961-2BA21	SITOP PSE200U 10 A SELECTIVITY MODULE 4-CHANNEL OUTPUT CURRENT CAN BE SET TO 3-10 PER CHANNEL	1 ¹⁾
INPUT: 3 AC 400-500 V, OUTPUT: 24 V/40 A DC		
6EP1437-3BA10	SITOP PSU8200 24V/40A STABILIZED POWER SUPPLY	2
6EP1961-3BA21	SITOP PSE202U REDUNDANCY MODULE OUTPUT CURRENT CAN BE SET TO 3-10 PER CHANNEL	2
6EP1961-2BA21	SITOP PSE200U 10 A SELECTIVITY MODULE 4-CHANNEL OUTPUT CURRENT CAN BE SET TO 3-10 PER CHANNEL	1 ¹⁾

Note

¹⁾ Depending on the requirements, the output current of the power supply unit can be distributed to several PSE200Us (signal contact can be looped across several PSE200Us).

The redundant power supply with selective monitoring of the 24 V feeders is particularly suitable for supplying power to the 24 V consumers at the field level.

17.5 Buffered power supply

A power failure not only interrupts the AC power supply but also the 24V supply and the automation system that is connected to it. Costly downtime and undefined system states can be the result.

The SITOP UPS1600 DC UPS with battery modules prevents this scenario by providing reliable backup of the 24 V supply for up to several hours. Depending on the version of the DC UPS, it is integrated into the control system by means of digital inputs / outputs or via PROFINET.

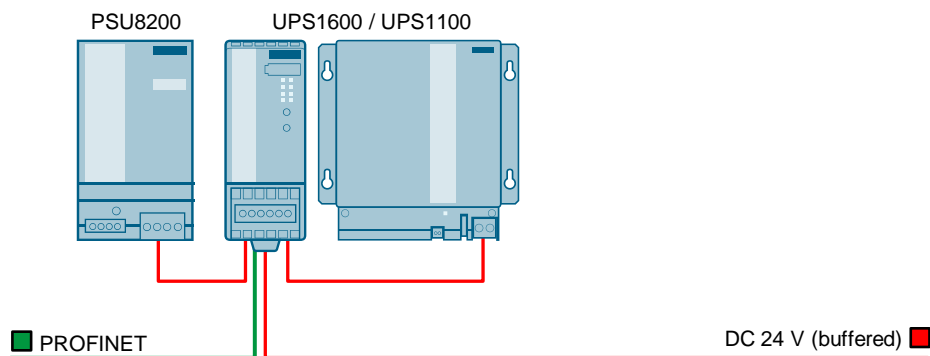

Bill of materials

Article number	Product description	Quantity
INPUT: 120/230 V AC, OUTPUT: 24 V/10 A DC		
6EP3334-8SB00-0AY0	SITOP PSU8200 24V/10A STABILIZED POWER SUPPLY	1
6EP4134-3AB00-2AY0	SITOP UPS1600 10A UNINTERRUPTIBLE POWER SUPPLY WITH ETHERNET/PROFINET INTERFACE	1
6EP4135-0GB00-0AY0	SITOP UPS1100 BATTERY MODULE WITH MAINTENANCE-FREE SEALED LEAD-ACID BATTERY FOR 24 V DC 12 AH SITOP DC UPS MODULES	1-6 ²⁾
INPUT: 120-230 V AC 110-220 V DC, OUTPUT: 24 V/20 A DC		
6EP1336-3BA10	SITOP PSU8200 20A STABILIZED POWER SUPPLY	1
6EP4136-3AB00-2AY0	SITOP UPS1600 20A UNINTERRUPTIBLE POWER SUPPLY WITH ETHERNET/PROFINET	1
6EP4135-0GB00-0AY0	SITOP UPS1100 BATTERY MODULE WITH MAINTENANCE-FREE SEALED LEAD-ACID BATTERY FOR 24 V DC 12 AH SITOP DC UPS MODULES	1-6 ²⁾
INPUT: 120-230 V AC 110-220 V DC, OUTPUT: 24 V/40 A DC		
6EP3337-8SB00-0AY0	SITOP PSU8200 40A STABILIZED POWER SUPPLY	1
6EP4136-3AB00-2AY0	SITOP UPS1600 20A UNINTERRUPTIBLE POWER SUPPLY WITH ETHERNET/PROFINET	1
6EP4135-0GB00-0AY0	SITOP UPS1100 BATTERY MODULE WITH MAINTENANCE-FREE SEALED LEAD-ACID BATTERY FOR 24 V DC 12 AH	1-6 ²⁾

SITOP DC UPS MODULES		
INPUT: 3 AC 400-500 V, OUTPUT: 24 V/20 A DC		
6EP3436-8SB00-0AY0	SITOP PSU8200 24 V/20 A STABILIZED POWER SUPPLY	1
6EP4136-3AB00-2AY0	SITOP UPS1600 20A UNINTERRUPTIBLE POWER SUPPLY WITH ETHERNET/PROFINET	1
6EP4135-0GB00-0AY0	SITOP UPS1100 BATTERY MODULE WITH MAINTENANCE-FREE SEALED LEAD-ACID BATTERY FOR 24 V DC 12 AH SITOP DC UPS MODULES	1-6 ²⁾
INPUT: 3 AC 400-500 V, OUTPUT: 24 V/40 A DC		
6EP1437-3BA10	SITOP PSU8200 24V 40A STABILIZED POWER SUPPLY	1
6EP4137-3AB000-2AY0	SITOP UPS1600 40A UNINTERRUPTIBLE POWER SUPPLY WITH ETHERNET/PROFINET	1
6EP4135-0GB00-0AY0	SITOP UPS1100 BATTERY MODULE WITH MAINTENANCE-FREE SEALED LEAD-ACID BATTERY FOR 24 V DC 12 AH SITOP DC UPS MODULES	1-6 ²⁾

Note

²⁾ The backup time is governed by the load current and the number of battery modules, see the table below.

When choosing the correct DC UPS configuration combined with other battery modules (lead, pure lead, LiFePo, and capacitances) the SITOP Selection Tool helps you in an optimum way:

www.siemens.com/sitop-selection-tool

Load current	Battery module 12 Ah (6EP4135-0GB00-0AY0)
4 A	2.3 h
6 A	1.4 h
10 A	48.6 min
20 A	19.6 min
40 A	8.5 min (2 x 12 Ah)

17.6 Redundant power supply with buffering

If you have more demanding requirements of a reliable 24 V supply, it is possible to combine a redundant power supply with a DC UPS. This ensures that 24 V power continues to be supplied even if a power supply fails or there is a power outage.

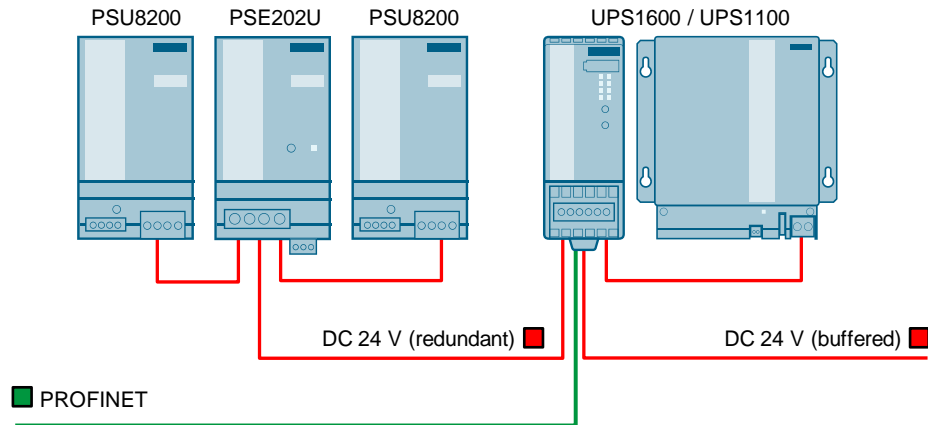

Bill of materials

Article number	Product description	Quantity
INPUT: 120/230 V AC, OUTPUT: 24 V/10 A DC		
6EP3334-8SB00-0AY0	SITOP PSU8200 24V/10A STABILIZED POWER SUPPLY	2
6EP1961-3BA21	SITOP PSE202U REDUNDANCY MODULE INPUT/OUTPUT: 24V/40A DC	1
6EP4134-3AB00-2AY0	SITOP UPS1600 10A UNINTERRUPTIBLE POWER SUPPLY WITH ETHERNET/PROFINET INTERFACE	1
6EP4135-0GB00-0AY0	SITOP UPS1100 BATTERY MODULE WITH MAINTENANCE-FREE SEALED LEAD-ACID BATTERY FOR 24 V DC 12 AH SITOP DC UPS MODULES	1-6 ²⁾
INPUT: 120-230 V AC 110-220 V DC, OUTPUT: 24 V/20 A DC		
6EP1336-3BA10	SITOP PSU8200 20A STABILIZED POWER SUPPLY	2
6EP1961-3BA21	SITOP PSE202U REDUNDANCY MODULE INPUT/OUTPUT: 24V/40A DC	1
6EP4136-3AB00-2AY0	SITOP UPS1600 20A UNINTERRUPTIBLE POWER SUPPLY WITH ETHERNET/PROFINET	1
6EP4135-0GB00-0AY0	SITOP UPS1100 BATTERY MODULE WITH MAINTENANCE-FREE SEALED LEAD-ACID BATTERY FOR 24 V DC 12 AH SITOP DC UPS MODULES	1-6 ²⁾

INPUT: 120-230 V AC 110-220 V DC, OUTPUT: 24 V/40 A DC		
6EP3337-8SB00-0AY0	SITOP PSU8200 40A STABILIZED POWER SUPPLY	2
6EP1961-3BA21	SITOP PSE202U REDUNDANCY MODULE INPUT/OUTPUT: 24V/40A DC	2
6EP4136-3AB00-2AY0	SITOP UPS1600 20A UNINTERRUPTIBLE POWER SUPPLY WITH ETHERNET/PROFINET	1
6EP4135-0GB00-0AY0	SITOP UPS1100 BATTERY MODULE WITH MAINTENANCE- FREE SEALED LEAD-ACID BATTERY FOR 24 V DC 12 AH SITOP DC UPS MODULES	1-6 ²⁾
INPUT: 3 AC 400-500 V, OUTPUT: 24 V/20 A DC		
6EP3436-8SB00-0AY0	SITOP PSU8200 24 V/20 A STABILIZED POWER SUPPLY	2
6EP1961-3BA21	SITOP PSE202U REDUNDANCY MODULE INPUT/OUTPUT: 24V/40A DC	1
6EP4136-3AB00-2AY0	SITOP UPS1600 20A UNINTERRUPTIBLE POWER SUPPLY WITH ETHERNET/PROFINET	1
6EP4135-0GB00-0AY0	SITOP UPS1100 BATTERY MODULE WITH MAINTENANCE- FREE SEALED LEAD-ACID BATTERY FOR 24 V DC 12 AH SITOP DC UPS MODULES	1-6 ²⁾
INPUT: 3 AC 400-500 V, OUTPUT: 24 V/40 A DC		
6EP1437-3BA10	SITOP PSU8200 24V 40A STABILIZED POWER SUPPLY	2
6EP1961-3BA21	SITOP PSE202U REDUNDANCY MODULE INPUT/OUTPUT: 24V/40A DC	2
6EP4137-3AB000-2AY0	SITOP UPS1600 40A UNINTERRUPTIBLE POWER SUPPLY WITH ETHERNET/PROFINET	1
6EP4135-0GB00-0AY0	SITOP UPS1100 BATTERY MODULE WITH MAINTENANCE- FREE SEALED LEAD-ACID BATTERY FOR 24 V DC 12 AH SITOP DC UPS MODULES	1-6 ²⁾

Note

²⁾ The backup time is governed by the load current and the number of battery modules, see the table below.

When choosing the correct DC UPS configuration combined with other battery modules (lead, pure lead, LiFePo, and capacitances) the SITOP Selection Tool helps you in an optimum way:

www.siemens.com/sitop-selection-tool

Load current	Battery module 12 Ah (6EP4135-0GB00-0AY0)
4 A	2.3 h
6 A	1.4 h
10 A	48.6 min
20 A	19.6 min
40 A	8.5 min (2 x 12 Ah)

17.7 Redundant power supply with redundant buffering

If the requirements of the 24 V power supply are particularly demanding, it is possible to set up the power supplies with DC UPS on a redundant basis. This ensures that 24V power continues to be supplied even if there is a power outage, or a power supply or DC UPS component fails.

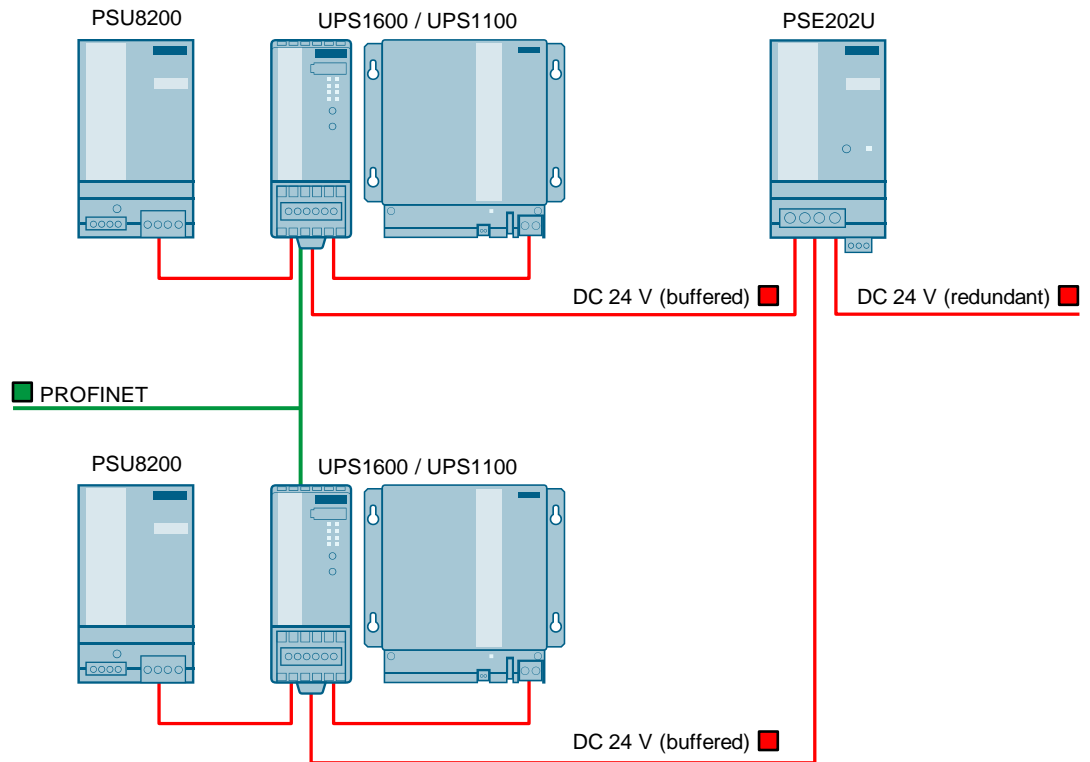

© Siemens AG 2019. All rights reserved.

Bill of materials

Article number	Product description	Quantity
INPUT: 120/230 V AC, OUTPUT: 24 V/10 A DC		
6EP3334-8SB00-0AY0	SITOP PSU8200 24V/10A STABILIZED POWER SUPPLY	2
6EP1961-3BA21	SITOP PSE202U REDUNDANCY MODULE INPUT/OUTPUT: 24V/40A DC	1
6EP4134-3AB00-2AY0	SITOP UPS1600 10A UNINTERRUPTIBLE POWER SUPPLY WITH ETHERNET/PROFINET INTERFACE	2
6EP4135-0GB00-0AY0	SITOP UPS1100 BATTERY MODULE WITH MAINTENANCE-FREE SEALED LEAD-ACID BATTERY FOR 24 V DC 12 AH SITOP DC UPS MODULES	2x 1-6 ²⁾

INPUT: 120-230 V AC 110-220V DC, OUTPUT: 24 V/20 A DC		
6EP1336-3BA10	SITOP PSU8200 20A STABILIZED POWER SUPPLY	2
6EP1961-3BA21	SITOP PSE202U REDUNDANCY MODULE INPUT/OUTPUT: 24V/40A DC	1
6EP4136-3AB00-2AY0	SITOP UPS1600 20A UNINTERRUPTIBLE POWER SUPPLY WITH ETHERNET/PROFINET	2
6EP4135-0GB00-0AY0	SITOP UPS1100 BATTERY MODULE WITH MAINTENANCE- FREE SEALED LEAD-ACID BATTERY FOR 24 V DC 12 AH SITOP DC UPS MODULES	2x 1-6 ²⁾
INPUT: 120-230 V AC 110-220 V DC, OUTPUT: 24 V/40 A DC		
6EP3337-8SB00-0AY0	SITOP PSU8200 40A STABILIZED POWER SUPPLY	2
6EP1961-3BA21	SITOP PSE202U REDUNDANCY MODULE INPUT/OUTPUT: 24V/40A DC	2
6EP4137-3AB00-2AY0	SITOP UPS1600 40A UNINTERRUPTIBLE POWER SUPPLY WITH ETHERNET/PROFINET	2
6EP4135-0GB00-0AY0	SITOP UPS1100 BATTERY MODULE WITH MAINTENANCE- FREE SEALED LEAD-ACID BATTERY FOR 24 V DC 12 AH SITOP DC UPS MODULES	2x 1-6 ²⁾
INPUT: 3 AC 400-500 V, OUTPUT: 24 V/20 A DC		
6EP3436-8SB00-0AY0	SITOP PSU8200 24 V/20 A STABILIZED POWER SUPPLY	2
6EP1961-3BA21	SITOP PSE202U REDUNDANCY MODULE INPUT/OUTPUT: 24V/40A DC	1
6EP4136-3AB00-2AY0	SITOP UPS1600 20A UNINTERRUPTIBLE POWER SUPPLY WITH ETHERNET/PROFINET	2
6EP4135-0GB00-0AY0	SITOP UPS1100 BATTERY MODULE WITH MAINTENANCE- FREE SEALED LEAD-ACID BATTERY FOR 24 V DC 12 AH SITOP DC UPS MODULES	2x 1-6 ²⁾
INPUT: 3 AC 400-500 V, OUTPUT: 24 V/40 A DC		
6EP1437-3BA10	SITOP PSU8200 24V 40A STABILIZED POWER SUPPLY	2
6EP1961-3BA21	SITOP PSE202U REDUNDANCY MODULE INPUT/OUTPUT: 24V/40A DC	2
6EP4137-3AB000-2AY0	SITOP UPS1600 40A UNINTERRUPTIBLE POWER SUPPLY WITH ETHERNET/PROFINET	2
6EP4135-0GB00-0AY0	SITOP UPS1100 BATTERY MODULE WITH MAINTENANCE- FREE SEALED LEAD-ACID BATTERY FOR 24 V DC 12 AH SITOP DC UPS MODULES	2x 1-6 ²⁾

Note

²⁾ The backup time is governed by the load current and the number of battery modules, see the table below.

When choosing the correct DC UPS configuration combined with other battery modules (lead, pure lead, LiFePo, and capacitances) the SITOP Selection Tool helps you in an optimum way:

www.siemens.com/sitop-selection-tool

Load current	Battery module 12 Ah (6EP4135-0GB00-0AY0)
4 A	2.3 h
6 A	1.4 h
10 A	48.6 min
20 A	19.6 min
40 A	8.5 min (2 x 12 Ah)

17.8 Power supply system with selective monitoring and buffering

The SITOP PSU8600 power supply system consists of a PSU8600 basic unit, up to four CNX8600 expansion modules with 4 or 8 outputs and a maximum of two BUF8600 respectively UPS8600 buffer modules with a connected BAT8600 battery. Depending on the expansion of the system, you can selectively monitor up to 36 DC outputs and bypass power outages of up to hours.

The modular system makes possible individual combination of the power supply system without any additional wiring. The order of the expansion modules and buffer modules is irrelevant in this case.

They are integrated into the control system via PROFINET. Comprehensive operating and diagnostic information is available such as the voltage and current values of the individual outputs.

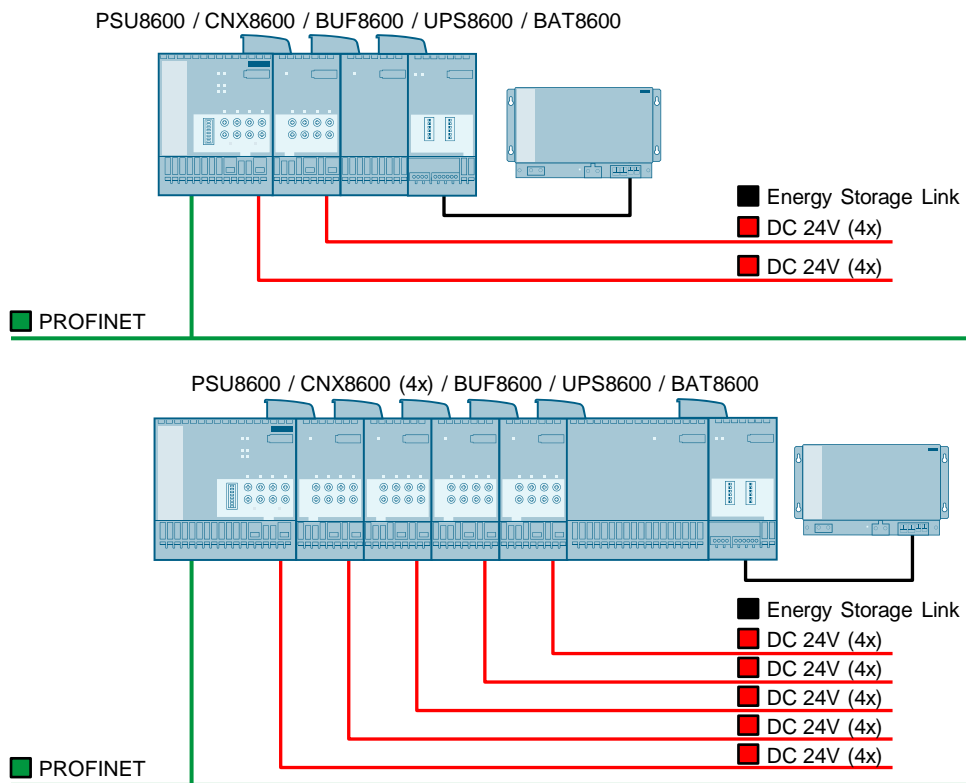

Bill of materials

Article number	Product description	Quantity
INPUT: 3 AC 400-500 V, OUTPUT: DC 24 V/20 A (4x 5 A)		
6EP3436-8MB00-2CY0	SITOP PSU8600 20 A PN (4x 5 A) Regulated power supply	1
6EP4436-8XB00-0CY0	SITOP CNX8600 (4x 5 A) expansion module ³⁾	0-4
6EP4295-8HB00-0XY0	SITOP BUF8600 - buffering capacity: 10 s/40 A	0-2
6EP4197-8AB00-0XY0	SITOP UPS8600 UPS module	0-2
6EP4143-8JB00-0XY0	SITOP BAT8600 LiFePO4 battery module, DC 48V/264 Wh	0-5 ⁴⁾
6EP4145-8GB00-0XY0	SITOP BAT8600 Pb battery module, DC 48V/380 Wh	0-5 ⁴⁾
INPUT: 3 AC 400-500 V, OUTPUT: DC 24 V/40 A (4x 10 A)		
6EP3437-8MB00-2AY0	SITOP PSU8600 40 A PN (4x 10 A) Regulated power supply	1
6EP4437-8XB00-0CY0	SITOP CNX8600 (4x 10 A) expansion module ³⁾	0-4
6EP4295-8HB00-0XY0	SITOP BUF8600 - buffering capacity: 10 s/40 A	0-2
6EP4197-8AB00-0XY0	SITOP UPS8600 UPS module	0-2
6EP4143-8JB00-0XY0	SITOP BAT8600 LiFePO4 battery module, DC 48V/264 Wh	0-5 ⁴⁾
6EP4145-8GB00-0XY0	SITOP BAT8600 Pb battery module, DC 48V/380 Wh	0-5 ⁴⁾

Note

³⁾ Depending on the requirements, the output current of the power supply unit can be distributed to other (max. 4 more) CNX8600s.

⁴⁾ Up to five SITOP BAT8600 of the same type can be used with each SITOP UPS8600 module.

Battery modules

Article number	Product description	Type
6EP4297-8HB00-0XY0	SITOP BUF8600 - buffering capacity: 100 ms/40 A	Buffer module
6EP4297-8HB10-0XY0	SITOP BUF8600 - buffer capacity: 300 ms/40 A	Buffer module
6EP4293-8HB00-0XY0	SITOP BUF8600 - buffer capacity: 4 s/ 40 A	Buffer module
6EP4295-8HB00-0XY0	SITOP BUF8600 - buffer capacity: 10 s/ 40 A	Buffer module

18 Possibilities for data exchange

Client / server system and OpenPCS 7

SIMATIC PCS 7 offers access to all real-time values, archive values, and messages at any time. The OpenPCS 7 software is the extensive interface for this access. It establishes the connection to the SIMATIC PCS 7 OS servers as well as to the Central Archive servers and offers access to all the data via standard OPC server technology. It combines OPC UA DA (Unified Architecture), OPC DA (Data Access), OPC HDA (Historical Data Access), OPC AE (Alarms & Events) and OPC HAE (Historical Alarms & Events) in one system.

In addition to this, it is also possible to achieve simple, standardized direct access to the archive data in the Microsoft SQL server database of the Operator System via OLE-DB.

Small system

Smaller systems benefit from a cost-effective combination of functionality from OpenPCS 7 and OS clients.

Large system

For large high-performance applications, OpenPCS 7 runs on a standalone PC and provides access to all the data that is located on multiple redundant SIMATIC PCS 7 systems composed of an OS server and a Process Historian.

18.1 Small OS client / OS server system and OpenPCS 7

In this configuration, the system has one OS server and one OS client.
The OpenPCS 7 Station is configured on an OS client.

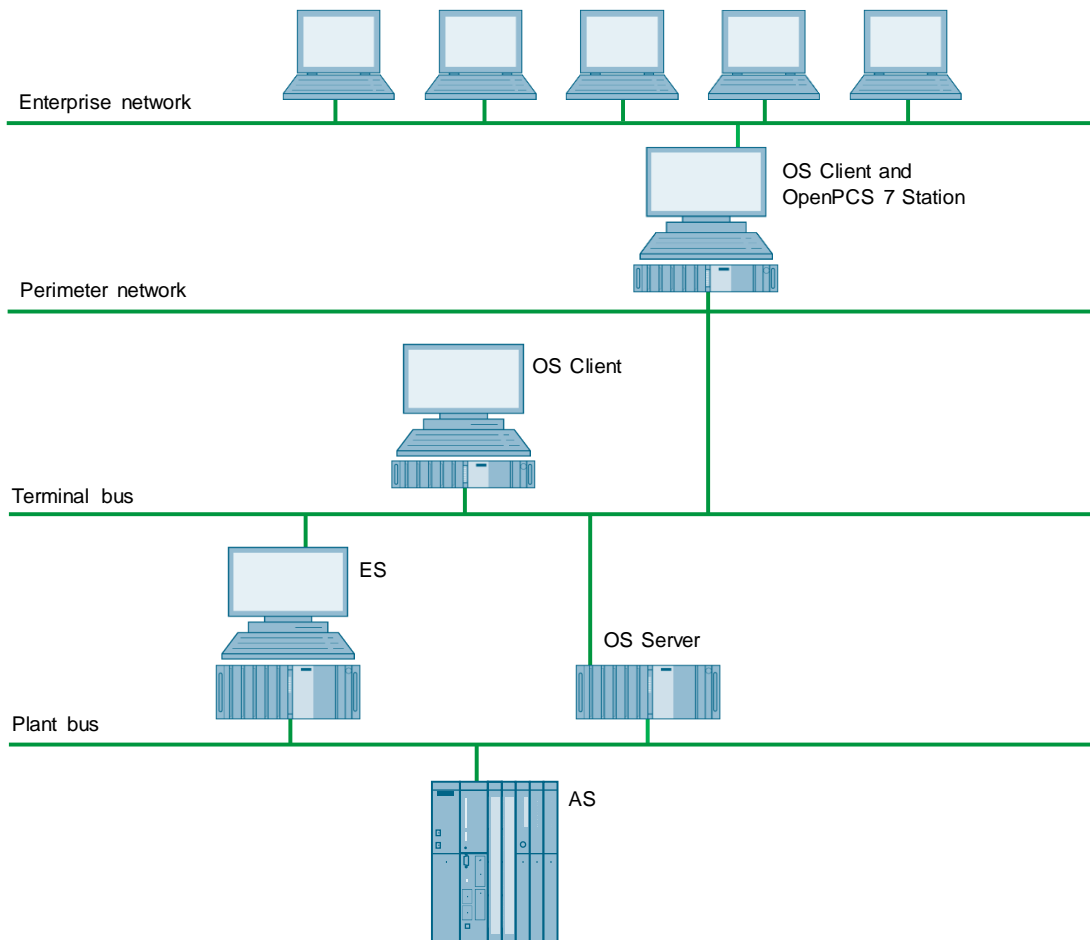

Bill of materials

Required	Optional	Article number	Product description	Note
Engineering system				
1		6ES7660-6DA10-3BA0	SIMATIC PCS 7 INDUSTRIAL WORKSTATION IPC847D, CORE I5, ES/OS SINGLESTATION, 500 GB HD SATA, 8GB DDR3, BCE, PCS 7 V9.0, WINDOWS 10 ENTERPRISE 2015 LTSB 64BIT	
1		6ES7658-5AX58-0YA5	SOFTWARE SIMATIC PCS 7 AS/OS ENGINEERING V9.0	
	1	6ES7658-1CX58-2YA5	SOFTWARE SIMATIC PCS 7 VERSION CROSS MANAGER V9.0	
	1	6ES7658-1FX58-2YA5	SOFTWARE SIMATIC PCS 7 VERSION TRAIL V9.0	
	1	6ES7658-1DX58-2YB5	SOFTWARE SIMATIC PCS 7 IMPORT EXPORT ASSISTANT V9.0	
OS server				
1		6ES7660-6EC10-3EA0	SIMATIC PCS 7 INDUSTRIAL WORKSTATION IPC847D, CORE I5, OS-SERVER, RAID1 (2 X 1 TB HDD SATA, DATA MIRRORING), 8GB DDR3, BCE, PCS 7 V9.0, WIN SERVER 2012 R2 STANDARD EDITION INCL. 5 CLIENT 64BIT	
1		6ES7658-2BA58-0YA0	SOFTWARE SIMATIC PCS 7 OS-SERVER V9.0 (PO 100)	1)
OS client				
1		6ES7660-5FA08-3BA0	SIMATIC PCS 7 INDUSTRIAL WORKSTATION IPC647D, CORE I5, OS-CLIENT, 500 GB HD SATA, 4GB DDR3, PCS 7 V9.0, WINDOWS 10 ENTERPRISE 2015 LTSB 64BIT	
1		6ES7658-2CX58-0YB5	SOFTWARE SIMATIC PCS 7 OS-CLIENT V9.0	
	1	6ES7652-0XD58-2YB5	SOFTWARE SIMATIC PCS 7 SFC VISUALIZATION V9.0	
OS client and OpenPCS 7 station				
1		6ES7660-5FA08-3BA0	SIMATIC PCS 7 INDUSTRIAL WORKSTATION IPC647D, CORE I5, OS-CLIENT, 500 GB HD SATA, 4GB DDR3, PCS 7 V9.0, WINDOWS 10 ENTERPRISE 2015 LTSB 64BIT	
1		A5E02639550	DESKTOP ADAPTER NETWORK CARD	3)
1		6ES7658-2CX58-0YB5	SOFTWARE SIMATIC PCS 7 OS-CLIENT V9.0	
1		6ES7658-0GX58-2YB0	SOFTWARE SIMATIC PCS 7 OPENPCS 7/OS-CLIENT V9.0	
	1	6ES7652-0XD58-2YB5	SOFTWARE SIMATIC PCS 7 SFC VISUALIZATION V9.0	

Required	Optional	Article number	Product description	Note
Automation system				
1		6ES7654-6CN03-3BF0	SIMATIC PCS 7 SINGLE AS, CPU 410-5H, 1X DP-MODULE, 2x PROFINET-IO, SYSTEM EXPANSION CARD 1000 PO, AS RT PO 100, CP443-1IE, UR2 ALU RACK, 1 X UC 120/230V 10A POWER SUPPLY	²⁾
		24 V DC power supply	Redundant power supply	Chapter 17.2

Note

¹⁾ The number of POs can be increased later by means of extra volume licenses.

²⁾ Please use the PCS 7 AS configurator, since different versions of the PCS 7 AS 410-5H are available; e. g., 24V DC or 110/230V AC.

³⁾ Necessary for the Enterprise network connection when using a redundant terminal bus.

Firewall applications between the terminal bus and the perimeter network, and between the perimeter network and the enterprise network are not listed but are necessary.

Network components for the perimeter network and enterprise network connection have not been listed.

18.2 Large OS client / OS server system and OpenPCS 7

In this configuration, the system has one redundant OS server pair and two OS clients. The Process Historian is set up on a redundant basis with a separate Information Server. The OpenPCS 7 Station is configured on a separate PC.

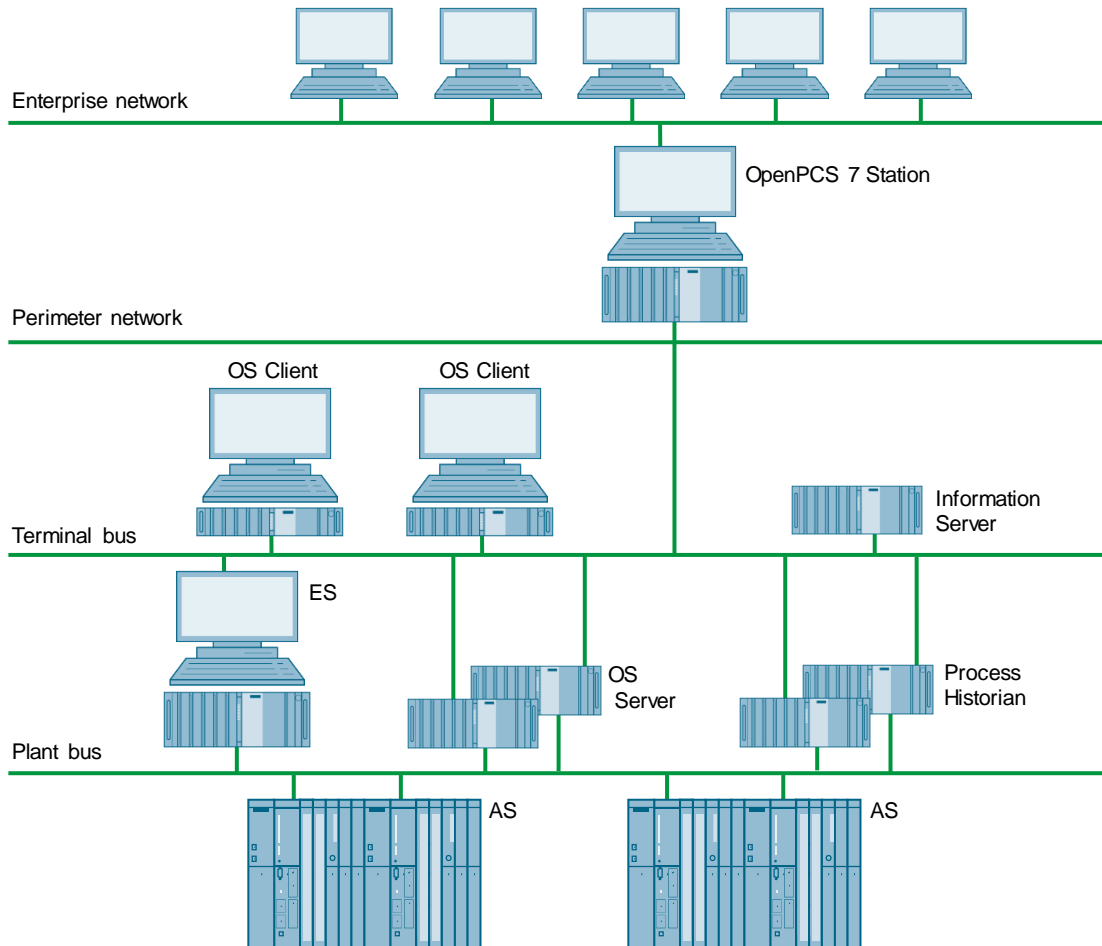

Bill of materials

Required	Optional	Article number	Product description	Note
Engineering system				
1		6ES7660-6DF11-3BA0	SIMATIC PCS 7 INDUSTRIAL WORKSTATION IPC847D, CORE I5, ES/OS SINGLESTATION, RAID1 (2 X 1 TB HDD SATA, DATA MIRRORING), 8GB DDR3, INDUSTRIAL ETHERNET (CP1623), PCS 7 V9.0, WINDOWS 10 ENTERPRISE 2015 LTSP 64BIT	
1		6ES7658-5AX58-0YA5	SOFTWARE SIMATIC PCS 7 AS/OS ENGINEERING V9.0	
1		6GK1162-3AA00	SIMATIC NET COMMUNICATION PROCESSOR CP 1623 PCI EXPRESS	1)
1		6GK1716-0HB14-0AC0	SIMATIC NET, S7-REDCONNECT POWERPACK V14	3)
1		6GK1711-1EW14-0AA0	SIMATIC NET SOFTNET-IE RNA V14 REDUNDANT NETWORK ACCESS	8)
	1	6ES7658-1CX58-2YA5	SOFTWARE SIMATIC PCS 7 VERSION CROSS MANAGER V9.0	
	1	6ES7658-1FX58-2YA5	SOFTWARE SIMATIC PCS 7 VERSION TRAIL V9.0	
	1	6ES7658-1DX58-2YB5	SOFTWARE SIMATIC PCS 7 IMPORT EXPORT ASSISTANT V9.0	
OS server				
2		6ES7660-6EF21-3EA0	SIMATIC PCS 7 INDUSTRIAL WORKSTATION IPC847D, CORE I5, OS-SERVER, RAID1 (2 X 1 TB HDD SATA, DATA MIRRORING), 16GB DDR3, INDUSTRIAL ETHERNET (CP1623), PCS 7 V9.0, WINDOWS SERVER 2012 R2 STANDARD EDITION, 64 BIT	
1		6ES7652-3BA58-2YA0	SOFTWARE SIMATIC PCS 7 OS-SERVER REDUNDANCY V9.0 (PO 100)	2) 7)
2		6GK1162-3AA00	SIMATIC NET COMMUNICATION PROCESSOR CP 1623 PCI EXPRESS	1)
2		6GK1716-0HB14-0AC0	SIMATIC NET, S7-REDCONNECT POWERPACK V14	3)
1		6GK1711-1EW14-0AA0	SIMATIC NET SOFTNET-IE RNA V14 REDUNDANT NETWORK ACCESS	8)

Required	Optional	Article number	Product description	Note
Process Historian				
2		6ES7660-6HN38-3EA0	SIMATIC PCS 7 INDUSTRIAL WORKSTATION IPC847D, XEON E3, OS-SERVER, RAID1 (2 x 1 TB HDD SATA, DATA MIRRORING) + 240GB SSD SATA, 32GB DDR3, PCS 7 V9.0 OPERATING SYSTEM WINDOWS SERVER 2012 R2 STANDARD EDITION, 64 BIT incl. 5 CAL	
2		A5E02639550	DESKTOP ADAPTER NETWORK CARD	6)
1		6XV1870-3RH60	SIMATIC NET INDUSTRIAL ETHERNET TP XP CORD RJ45/RJ45, 6M	
1		6ES7652-7CX58-2YB0	SOFTWARE SIMATIC PCS 7 PROCESS HISTORIAN SERVER REDUNDANCY V9.0	5)
1		6GK1711-1EW14-0AA0	SIMATIC NET SOFTNET-IE RNA V14 REDUNDANT NETWORK ACCESS	8)
Information Server				
1		6ES7660-5FA08-3BA0	SIMATIC PCS 7 INDUSTRIAL WORKSTATION IPC647D, CORE I5, OS-CLIENT, 500 GB HD SATA, 4GB DDR3, PCS 7 V9.0, WINDOWS 10 ENTERPRISE 2015 LTSB 64BIT	
1		6GK1711-1EW14-0AA0	SIMATIC NET SOFTNET-IE RNA V14 REDUNDANT NETWORK ACCESS	8)
1		6ES7652-7EX58-2YB0	SOFTWARE SIMATIC PCS 7 INFORMATION SERVER BASIC PACKAGE V9.0	7)
1		6ES7652-7YA00-2YB0	SOFTWARE SIMATIC PCS 7 INFORMATION SERVER CLIENT ACCESS 1 CLIENT	
OS client				
2		6ES7660-5FA08-3BA0	SIMATIC PCS 7 INDUSTRIAL WORKSTATION IPC647D, CORE I5, OS-CLIENT, 500 GB HD SATA, 4GB DDR3, PCS 7 V9.0, WINDOWS 10 ENTERPRISE 2015 LTSB 64BIT	
2		6ES7658-2CX58-0YB5	SOFTWARE SIMATIC PCS 7 OS-CLIENT V9.0	
2		6GK1711-1EW14-0AA0	SIMATIC NET SOFTNET-IE RNA V14 REDUNDANT NETWORK ACCESS	8)
2		6ES7652-0XD58-2YB5	SOFTWARE SIMATIC PCS 7 SFC VISUALIZATION V9.0	
OpenPCS 7 station				
1		6ES7660-5FA08-3BA0	SIMATIC PCS 7 INDUSTRIAL WORKSTATION IPC647D, CORE I5, OS-CLIENT, 500 GB HD SATA, 4GB DDR3, PCS 7 V9.0, WINDOWS 10 ENTERPRISE 2015 LTSB 64BIT	
1		A5E02639550	DESKTOP ADAPTER NETWORK CARD	6)
1		6ES7658-0HX58-2YB0	SOFTWARE SIMATIC PCS 7 OPENPCS 7 V9.0	
1		6GK1711-1EW14-0AA0	SIMATIC NET SOFTNET-IE RNA V14 REDUNDANT NETWORK ACCESS	8)

Required	Optional	Article number	Product description	Note
Automation system				
2		6ES7656-6CP33-1CF0	SIMATIC PCS 7 REDUNDANCY AS, 2X CPU 410-5H, 2 DP-MODULE, 2X PROFINET-IO, SYSTEM EXPANSION CARD 1600, AS RT PO 100, 2 X 2 10M SYNC-MODULES AND 2 X 1M FO, 2 X CP443-1 IE/PN, 1 X UR2-H ALU RACK, 2 X UC 120/230V 10A RED. POWER SUPPLY	⁴⁾
		24 V DC power supply	Redundant power supply	Chapter 17.2

Note

- ¹⁾ Needed if a redundant system bus is chosen.
 - ²⁾ The number of POs can be increased later by means of extra volume licenses.
 - ³⁾ Necessary if a redundant system bus or a redundant automation system is chosen.
 - ⁴⁾ Please use the PCS 7 AS configurator, since different versions of the PCS 7 AS 410-5H are available; e. g., 24V DC or 110/230V AC.
 - ⁵⁾ The tag inventory can be expanded using cumulative volume licenses (SIMATIC PCS 7 OS/PH Archive up to a maximum of 120,000 archive tags).
 - ⁶⁾ Necessary for the Enterprise network connection when using a redundant terminal bus.
 - ⁷⁾ The redundant OS server pair is supplied with an RS-232 serial connection cable. If there is a long distance between the redundant systems, you can use an Ethernet connection instead. This requires additional Ethernet network interface cards in the systems.
 - ⁸⁾ The onboard interfaces can be used.
Single License for one installation. Necessary if a redundant terminal bus is selected.
- Firewall applications between the terminal bus and the perimeter network, and between the perimeter network and the enterprise network are not listed but are necessary.
- Network components for perimeter network and enterprise network connection are not listed.

19 AS-OS PO counting

19.1 Process objects

The following applies to the licensing of process objects (POs) in SIMATIC PCS 7 V 9.0:

The following are counted as process objects by PCS 7:

- all SFCs
- all block instances that meet the following criteria:
 - they can be operated and monitored
 - they generate messages
 - they are not diagnostic modules

These objects are transferred to the OS and require a license.

Blocks that can be operated and monitored have the attribute "S7_m_c = true" in their block properties.

Process objects can include the following blocks and objects:

- Blocks for operator control and monitoring of a plant
- Objects for automation
- Objects for signal capture and processing

As a general rule, 0.75...1.5 I/Os correspond to one process object.

For PCS 7 licensing, the total number of process objects is counted regardless of the number of inputs and outputs. The data that is exchanged with other automation systems also has no effect on the number of process objects.

Note The described PO count may vary for individual blocks. For example, the Model Predictive Controller (MPC) controller block is counted with 100 POs.

Note Under the following link, you can find an FAQ on how to count POs:
<https://support.industry.siemens.com/cs/ww/en/view/38855207>
You can find more information about licenses and quantity structures in the manual "SIMATIC PCS 7 Licenses and configuration limits V9.0":
<https://support.industry.siemens.com/cs/ww/en/view/109746549>

19.2 Cumulative licenses

The cumulative licenses below are available for individual SIMATIC software products:

Article number	Product description
AS Runtime license	
6ES7653-2BA00-0XB5	SOFTWARE SIMATIC PCS 7 RUNTIME LICENSE AS (PO 100)
6ES7653-2BB00-0XB5	SOFTWARE SIMATIC PCS 7 RUNTIME LICENSE AS (PO 1000)
6ES7653-2BC00-0XB5	SOFTWARE SIMATIC PCS 7 RUNTIME LICENSE AS (PO 10,000)
OS Runtime license	
6ES7658-2XA00-0XB0	SOFTWARE SIMATIC PCS 7 OS RUNTIME LICENSE (PO 100)
6ES7658-2XB00-0XB0	SOFTWARE SIMATIC PCS 7 OS RUNTIME LICENSE (PO 1000)
6ES7658-2XC00-0XB0	SOFTWARE SIMATIC PCS 7 OS RUNTIME LICENSE (PO 5000)
OS archive	
6ES7658-2EA00-2YB0	SIMATIC PCS 7, OS Archive (1.500 VAR)
6ES7658-2EB00-2YB0	SIMATIC PCS 7, OS Archive (5.000 VAR)
6ES7658-2EC00-2YB0	SIMATIC PCS 7, OS ARCHIVE (10.000 VAR)
6ES7658-2ED00-2YB0	SIMATIC PCS 7, OS ARCHIVE (30.000 VAR)
PDM	
6ES7658-3XC00-2YB5	SIMATIC PDM (10 TAGs)
6ES7658-3XD00-2YB5	SIMATIC PDM (100 TAGs)
6ES7658-3XE00-2YB5	SIMATIC PDM (1000 TAGs)
BATCH	
6ES7657-0XA00-0YB0	SIMATIC PCS 7, SIMATIC BATCH (1 UNIT)
6ES7657-0XB00-0YB0	SIMATIC PCS 7, SIMATIC BATCH (10 UNITS)
6ES7657-0XC00-0YB0	SIMATIC PCS 7, SIMATIC BATCH (50 UNITS)
Route Control Routes	
6ES7658-7FF00-0XB0	SIMATIC PCS 7, SIMATIC ROUTE CONTROL (10 ROUTES)
6ES7658-7FG00-0XB0	SIMATIC PCS 7, SIMATIC ROUTE CONTROL (50 ROUTES)
Maintenance RT	
6ES7658-7GB00-2YB0	SIMATIC PCS7, MAINTENANCE STATION RUNTIME (100 TAGs)
6ES7658-7GC00-2YB0	SIMATIC PCS7, MAINTENANCE STATION RUNTIME (1000 TAGs)
SIMATIC Management Console	
6ES7658-5BA00-2YB5	SIMATIC PCS 7, MANAGEMENT CONSOLE (10 AGENTS)
6ES7658-5BB00-2YB5	SIMATIC PCS 7, MANAGEMENT CONSOLE (50 AGENTS)
6ES7658-5BC00-2YB5	SIMATIC PCS 7, MANAGEMENT CONSOLE (100 AGENTS)

Article number	Product description
Information Server – Client Access	
6ES7652-7YA00-2YB0	SIMATIC PCS 7, INFORMATION SERVER (1 CLIENT)
6ES7652-7YB00-2YB0	SIMATIC PCS 7, INFORMATION SERVER (3 CLIENTS)
6ES7652-7YC00-2YB0	SIMATIC PCS 7, INFORMATION SERVER (5 CLIENTS)
6ES7652-7YD00-2YB0	SIMATIC PCS 7, INFORMATION SERVER (10 CLIENTS)
Information Server – Data Source Access	
6ES7652-7YE00-2YB0	SIMATIC PCS 7, INFORMATION SERVER DATASOURCE ACCESS (1 SOURCE)
6ES7652-7YF00-2YB0	SIMATIC PCS 7, INFORMATION SERVER DATASOURCE ACCESS (3 SOURCES)
OS Web server	
6ES7658-2GE00-0XB0	SIMATIC PCS 7, WEB SERVER (1 CLIENT)
6ES7658-2GF00-0XB0	SIMATIC PCS 7, WEB SERVER (5 CLIENTS)
6ES7658-2GG00-0XB0	SIMATIC PCS 7, WEB SERVER (10 CLIENTS)
Information Server – Data Source Access	
6ES7652-7YE00-2YB0	SIMATIC PCS 7, INFORMATION SERVER DATASOURCE ACCESS (1 SOURCE)
6ES7652-7YF00-2YB0	SIMATIC PCS 7, INFORMATION SERVER DATASOURCE ACCESS (3 SOURCES)

20 Service and Support

Industry Online Support

Do you have any questions or need assistance?

Siemens Industry Online Support offers round the clock access to our entire service and support know-how and portfolio.

The Industry Online Support is the central address for information about our products, solutions and services.

Product information, manuals, downloads, FAQs, and application examples – all the information you need is accessible with just a few mouse clicks at:

<https://support.industry.siemens.com/>

Industry Online Support app

You will receive optimum support wherever you are with the "Siemens Industry Online Support" app. The app is available for Apple iOS, Android and Windows Phone:

<https://support.industry.siemens.com/cs/ww/en/sc/2067>

Technical Support

The Technical Support of Siemens Industry provides you fast and competent support regarding all technical queries with numerous tailor-made offers – ranging from basic support to individual support contracts.

Queries can be sent to Technical Support using the web form at:

www.siemens.com/industry/supportrequest

Service offer

Our range of services includes, inter alia, the following:

- Product trainings
- Plant data services
- Spare parts services
- Repair services
- On-site and maintenance services
- Retrofitting and modernization services
- Service programs and contracts

You can find detailed information on our range of services in the service catalog at:

<https://support.industry.siemens.com/cs/sc>

Contacts

If you want to request on-site service or need spare parts, please get in touch with your local Siemens representative, He/she will put you in contact with the responsible service center. You can find your contact person in the contact database:

www.siemens.com/yourcontact

21 Appendix

21.1 References

Table 21-1

	Topic
\1\	Siemens Industry Online Support https://support.industry.siemens.com
\2\	Article download page https://support.industry.siemens.com/cs/ww/de/view/109751791
\3\	SIMATIC PCS 7 Standard Architectures (V9.0 / V8.2 / V8.1 / V8.0 / V7.1 / V7.0) https://support.industry.siemens.com/cs/ww/en/view/32201963
\4\	SIMATIC PCS 7 technical documentation – Manuals collection http://w3.siemens.com/mcms/industrial-automation-systems-simatic/en/manual-overview/tech-doc-pcs7/Pages/Default.aspx
\5\	SIMATIC PCS 7 - PC Configuration (V9.0) https://support.industry.siemens.com/cs/ww/en/view/109749317
\6\	SIMATIC Process Control System PCS 7 Licenses and configuration limits (V9.0) https://support.industry.siemens.com/cs/ww/en/view/109746549
\7\	PROFINET in Process Automation with SIMATIC PCS 7 https://support.industry.siemens.com/cs/ww/en/view/72887082

21.2 History

Table 21-2

Version	Date	Change
V1.0	07/2016	First edition V8.2
V2.0	11/2017	Complete revision of SIMATIC PCS 7 V9.0
V2.1	10/2018	Chapter 6.3: Bill of materials supplemented Chapter 15.4.2: A note was added below the table "bill of materials for concept 2 and 3". Chapter 15.4.3: Notes were added below the table "bill of materials for concept 4".
V2.2	03/2019	Chapter 17.8: Power supply system SITOP 8600 extended by: <ul style="list-style-type: none"> - UPS module UPS8600 - Battery module BAT8600 LiFePO2 - Battery module BAT8600 Pb